

Installation Instructions

Series LF150A/LF150-HA

Water Hammer Arrestor

⚠ WARNING



Read this Manual **BEFORE** using this equipment.

Failure to read and follow all safety and use information can result in death, serious personal injury, property damage, or damage to the equipment.

Keep this Manual for future reference.



LF150A

Installation Instructions

- Install as close as possible to source of shock.
- Avoid damaging arrestor by using hex flats to tighten.
- Unit is factory pre-charged to 30psi (207 kPa). If system pressure is higher than 35psi (241 kPa), add air until the valve is 5psi (34 kPa) below the system flow pressure.
- Use LF150HA hose adapter for hose applications such as direct mounting to Watts Model 2, Duo-Cloz washing machine shutoff valve.
- Maximum working pressure 150psi (10.3 kPa).

Clothes and Dishwashers

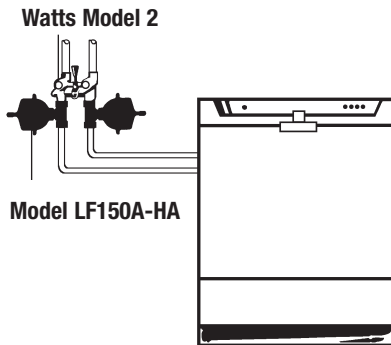

Dimensions

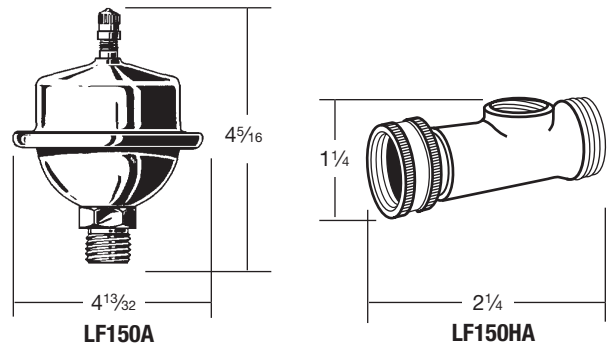

Quick-Closing Faucets

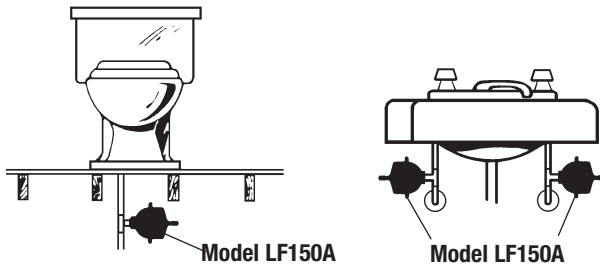

NOTICE

Annual inspection of all water system safety and control valves is required and necessary. Regular inspection, testing and cleaning assures maximum life and proper product function.

How It Operates

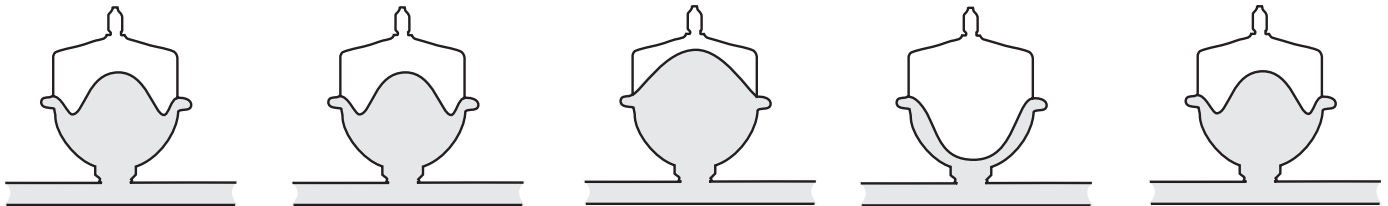

1. When water in the house is not being used, the LF150A is in its normal state, where the air charge and water pressure do not flex the diaphragm.

2. When the water is being used, the LF150A is still in balance of air pressure and water pressure, the diaphragm does not flex.

3. When water is quickly shut off, the sudden halt causes the water pressure to soar and the shock is absorbed by the diaphragm.

Followed by a sudden drop, which also acts on the diaphragm, flexing it silently to handle the pressure changes.

4. Seconds after the shock, the diaphragm is back in its normal stage.

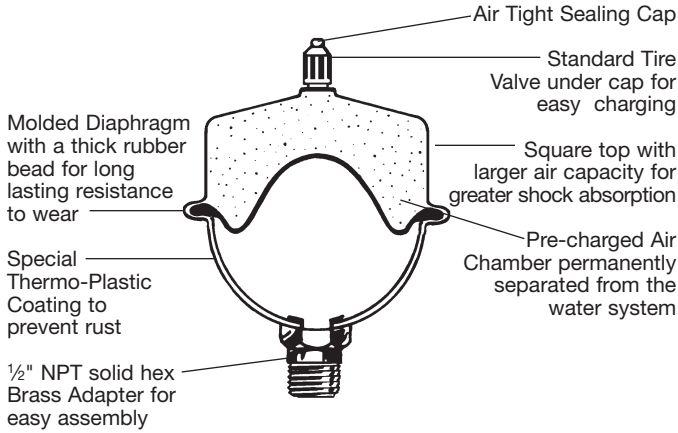

Selection Table

PIPE SIZE		LENGTH PIPE UP TO		FLOW PRESSURE - PSI AND NUMBER OF 150A VALVES TO INSTALL						
<i>in.</i>	<i>ft.</i>	<i>mtr</i>	30 (2.11) <i>psi (bar)</i>	40 (2.81) <i>psi (bar)</i>	50 (3.52) <i>psi (bar)</i>	60 (4.22) <i>psi (bar)</i>	70 (4.92) <i>psi (bar)</i>	80 (5.62) <i>psi (bar)</i>	90 (6.33) <i>psi (bar)</i>	100 (7.03) <i>psi (bar)</i>
1/2	50	15.24	1	1	1	1	1	1	2	2
	75	22.86	1	1	1	1	2	2	2	—
	100	30.48	1	1	2	2	2	2	—	—
3/4	25	7.62	1	1	1	1	1	1	2	•
	50	15.24	1	1	2	2	2	2	—	—
	75	22.86	1	1	1	1	—	—	—	—
1	25	7.62	1	1	1	1	2	2	2	—
	50	15.24	2	2	2	2	—	—	—	—
	75	22.86	—	—	—	—	—	—	—	—
1 1/4	25	7.62	2	2	2	2	2	—	—	—

Chart based on 10 FPS (3.05 MPS) velocity and 150psi (10.55 bar) shock pressure.

NOTICE

Metric equivalents shown are for comparison reference only.

WARNING: This product contains chemicals known to the State of California to cause cancer and birth defects or other reproductive harm.
For more information: www.watts.com/prop65

Limited Warranty: Watts Regulator Co. (the "Company") warrants each product to be free from defects in material and workmanship under normal usage for a period of one year from the date of original shipment. In the event of such defects within the warranty period, the Company will, at its option, replace or recondition the product without charge.

THE WARRANTY SET FORTH HEREIN IS GIVEN EXPRESSLY AND IS THE ONLY WARRANTY GIVEN BY THE COMPANY WITH RESPECT TO THE PRODUCT. THE COMPANY MAKES NO OTHER WARRANTIES, EXPRESS OR IMPLIED. THE COMPANY HEREBY SPECIFICALLY DISCLAIMS ALL OTHER WARRANTIES, EXPRESS OR IMPLIED, INCLUDING BUT NOT LIMITED TO THE IMPLIED WARRANTIES OF MERCHANTABILITY AND FITNESS FOR A PARTICULAR PURPOSE.

The remedy described in the first paragraph of this warranty shall constitute the sole and exclusive remedy for breach of warranty, and the Company shall not be responsible for any incidental, special or consequential damages, including without limitation, lost profits or the cost of repairing or replacing other property which is damaged if this product does not work properly, other costs resulting from labor charges, delays, vandalism, negligence, fouling caused by foreign material, damage from adverse water conditions, chemical, or any other circumstances over which the Company has no control. This warranty shall be invalidated by any abuse, misuse, misapplication, improper installation or improper maintenance or alteration of the product.

Some States do not allow limitations on how long an implied warranty lasts, and some States do not allow the exclusion or limitation of incidental or consequential damages. Therefore the above limitations may not apply to you. This Limited Warranty gives you specific legal rights, and you may have other rights that vary from State to State. You should consult applicable state laws to determine your rights. **SO FAR AS IS CONSISTENT WITH APPLICABLE STATE LAW, ANY IMPLIED WARRANTIES THAT MAY NOT BE DISCLAIMED, INCLUDING THE IMPLIED WARRANTIES OF MERCHANTABILITY AND FITNESS FOR A PARTICULAR PURPOSE, ARE LIMITED IN DURATION TO ONE YEAR FROM THE DATE OF ORIGINAL SHIPMENT.**



A Watts Water Technologies Company



USA: Tel. (978) 688-1811 • Fax: (978) 794-1848 • www.watts.com

Canada: Tel. (905) 332-4090 • Fax: (905) 332-7068 • www.watts.ca