



Installation, Maintenance, & Repair

Series 909 and LF909

Reduced Pressure Zone Assemblies

Sizes: 3/4" – 2" (20-50mm)

⚠ WARNING	
	<p>Read this Manual BEFORE using this equipment.</p> <p>Failure to read and follow all safety and use information can result in death, serious personal injury, property damage, or damage to the equipment.</p>
	<p>Keep this Manual for future reference.</p>
	

Local building or plumbing codes may require modifications to the information provided. You are required to consult the local building and plumbing codes prior to installation. If this information is not consistent with local building or plumbing codes, the local codes should be followed.

Need for Periodic Inspection/Maintenance: This product must be tested periodically in compliance with local codes, but at least once per year or more as service conditions warrant. Corrosive water conditions, and/or unauthorized adjustments or repair could render the product ineffective for the service intended. Regular checking and cleaning of the product's internal components helps assure maximum life and proper product function.

Testing

For field testing procedure, refer to Watts installation sheets IS-TK-DP/DL, IS-TK-9A, IS-TK-99E and IS-TK-99D found on www.watts.com.

For other repair kits and service parts, refer to our Backflow Prevention Products Repair Kits & Service Parts price list PL-RP-BPD found on www.watts.com.

For technical assistance, contact your local Watts representative.

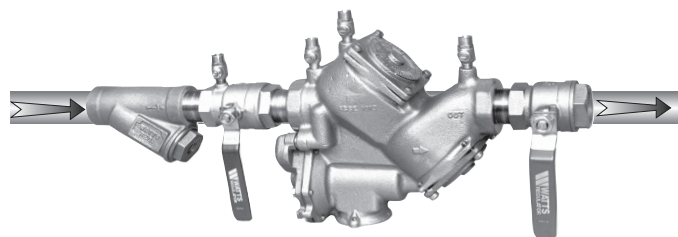

No. 909QT-S 1 1/2" shown

NOTICE

Inquire with governing authorities for local installation requirements

NOTICE

For Australia and New Zealand, line strainers should be installed between the upstream shutoff valve and the inlet of the backflow preventer.

Its important that this device be tested periodically in compliance with local codes, but at least once per year or more as service conditions warrant. If installed on a fire sprinkler system, all mechanical checks, such as alarm checks and backflow preventers, should be flow tested and inspected internally in accordance with NFPA 13 and NFPA 25.

Basic Installation Instructions

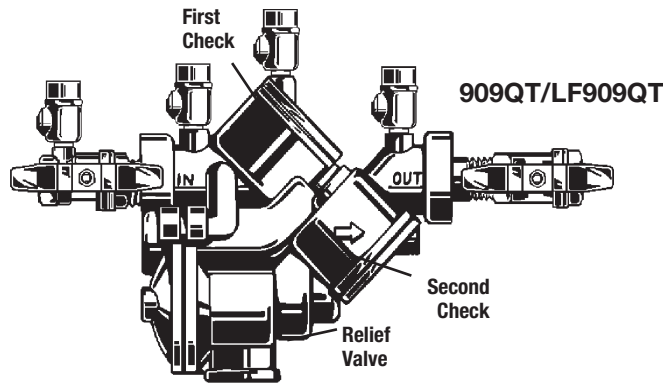

Watts 3/4" – 2" (20-50mm) 909QT/LF909QT High Capacity Relief Series: Location and Installation Considerations

1. Backflow preventers must be installed in high-visibility locations in order to allow for immediate notice of telltale discharge or other malfunction. This location should also facilitate testing and servicing, and protect against freezing and vandalism.
2. Installing a backflow preventer in a pit or vault is not recommended as flooding of the pit will cause a crossconnection. Ensure that **all local codes and required safety provisions are met**. An air gap below the relief port must be maintained so as to avoid, flooding and submersion of the assembly, which may lead to a cross-connection.
3. A strainer should be installed ahead of the backflow preventer to protect all internal components from unnecessary fouling.
4. Normal discharge and nuisance spitting are accommodated by the use of a Watts air gap fitting and a fabricated indirect waste line. Floor drains of the same size **MUST** be provided in case of excessive discharge.
5. When a 909 and LF909 Series backflow preventer is installed for dead-end service applications (i.e. boiler feed lines, cooling tower makeup or other equipment with periodic flow requirements), discharge from the relief vent may occur due to water supply pressure fluctuation during static no-flow conditions. A check valve may be required ahead of the backflow preventer. *Please see "Troubleshooting", page 7, **prior to installation**.
6. The 909 and LF909 Series backflow preventer is designed so that the critical level of the relief valve is positioned below the first check. This unique feature allows the valve to be **installed either vertically or horizontally**.
7. **Installation procedures must comply with all state and local codes.** *Please see page 3 for specific installation procedures.
8. Prior to installation, thoroughly flush all pipe lines to remove any foreign matter.
9. **Start up** at Initial Installations and After Servicing: The downstream shutoff should be closed. Slowly open upstream shutoff and allow the backflow preventer to fill slowly. Bleed air at each test cock. When backflow preventer is filled, slowly open the downstream shutoff and fill the water supply system. This is necessary to avoid dislodging O-rings or causing damage to internal components.
10. **Test:** The 909 and LF909 Series backflow preventer must be tested by a certified tester at the time of installation in order to ascertain that the assembly is in full working order and may be relied upon to protect the safe drinking water as per applicable standards.

⚠ CAUTION

Do not install a strainer ahead of the backflow preventer on seldom-used, emergency water lines (i.e. fire sprinkler lines). The strainer mesh could potentially become clogged with debris present in the water and cause water blockage during an emergency.

For repair kits and parts, refer to our Backflow Prevention Products Repair Kits & Service Parts price list PL-RP-BPD found on www.watts.com.

How It Operates

The unique relief valve construction incorporates two channels: one for air, one for water. When the relief valve opens, as in the accompanying air-in/water-out diagram, the right hand channel admits air to the top of the reduced pressure zone, relieving the zone vacuum. The channel on the left then drains the zone to atmosphere. Therefore, if both check valves foul, and simultaneous negative supply and positive backpressure develops, the relief valve uses the air-in/water-out principle to stop potential backflow.

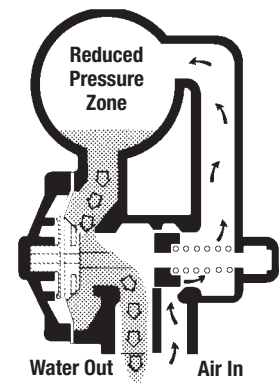

Installation Indoors

ASSE approved for vertical installation
3/4" - 2" flow up and down

For indoor installations, it is important that the valve be easily accessible to facilitate testing and servicing. Series 909 and LF909 may be installed either vertically or horizontally. If it is located in a line close to wall, be sure the test cocks are easily accessible. A drain line and air gap should be piped from the relief valve connection as shown, where evidence of discharge will be clearly visible and so that water damage will not occur. Therefore, never install in concealed locations.

NOTICE

Test cock must be located on the first or inlet shutoff valve.

***For Air Gap information contact your technical sales representative or refer to ES-AG/EL/TC.**

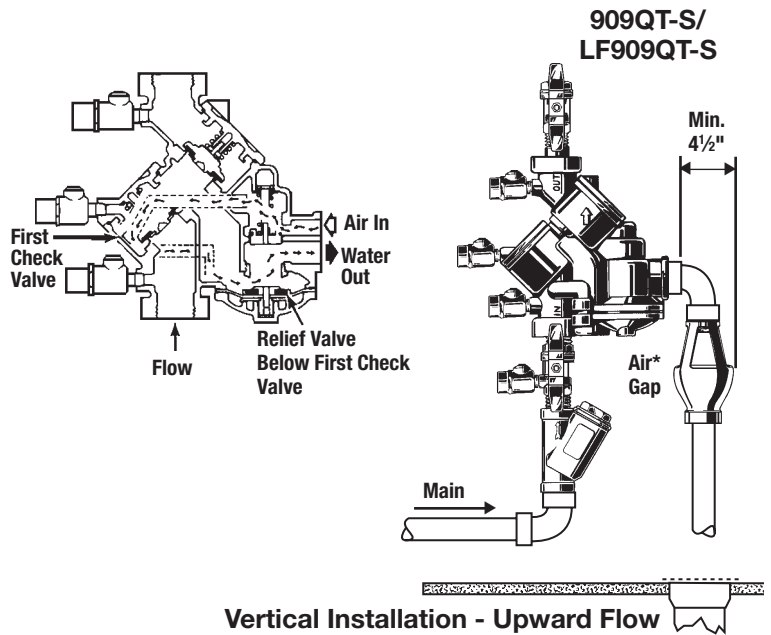

Installation - Outside Building Above Ground

In an area where freezing conditions do not occur, Series 909/LF909 can be installed outside of a building. The most satisfactory installation is above ground and should be installed in this manner whenever possible.

In an area where freezing conditions can occur, Series 909/LF909 should be installed above ground in an insulated enclosure.

Series 909/LF909 may be installed in a vertical or horizontal line and in an accessible location to facilitate testing and servicing. A discharge line should be piped from the air gap at the relief valve connection making sure there is adequate drainage. Never pipe the discharge line directly into a drainage ditch, sewer or sump. Series 909 and Series LF909 should never be installed where any part of the unit could become submerged in standing water. Consideration should be given to the installation of external support structure as applicable.

It is generally recommended that backflow preventers never be placed in pits unless absolutely necessary, and then only, when approved by local codes. In such cases, a modified pit installation is preferred.

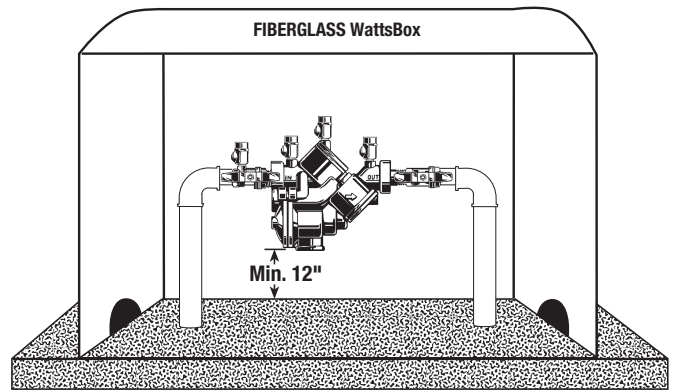

Now available, WattsBox Insulated Enclosures, for more information, send for ES-WB or ES-WB-T.

Installation - Parallel Consult Local Codes for Approval

Two or more smaller size valves can be piped in parallel (when approved) to serve a larger supply pipe main. This type of installation is employed where increased capacity is needed beyond that provided by a single valve and permits testing or servicing of an individual valve without shutting down the complete line.

The number of valves used in parallel should be determined by the engineer's judgement based on the operating conditions of a specific installation.

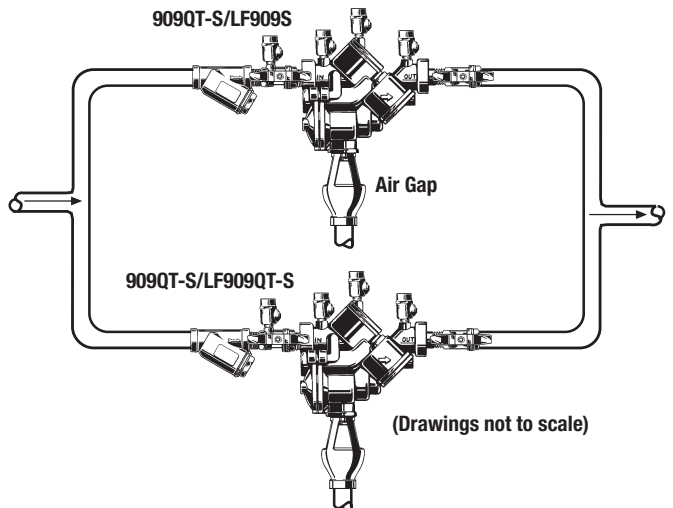
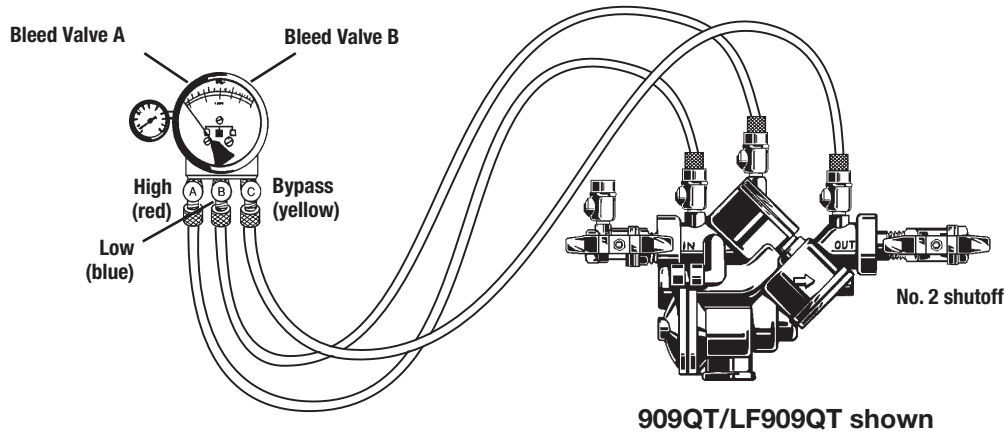

TABLE ONE - CAPACITY REQUIRED FOR SYSTEM					
50 gpm	100 gpm	150 gpm	200 gpm	250 gpm	350 gpm
Two 3/4"	Two 1"	Two 1 1/4"	Two 1 1/2"	Two 1 1/2"	Two 2"
Devices	Devices	Devices	Devices	Devices	Devices

Table shows total capacity provided with dual valve installations of various sizes.

Test Procedure for Reduced Pressure Assembly

- A. All needle valves must be closed on test kit.
- B. Open test cock No. 4 and flush test cocks Nos. 1, 2 and 3 on reduced pressure assembly then close test cock No. 4.
- C. Attach hoses as shown. Bleed air from kit, close No. 2 shutoff.



Test No. 1 - Check Valve No.2

Purpose: To test check valve No. 2 for tightness against reverse flow.

Requirements: Valve must be tight against reverse flow under all pressure differentials.

- Step 1** Slowly open the needle valve "A" high side (red) and "C" bypass (yellow). Keep the "B" low (blue) closed.
- Step 2** Open test cock No. 4.
- Step 3** Indicated pressure differential will decrease slightly. If pressure differential continues to decrease (until the vent opens) the No. 2 check valve is reported as "leaking".

Test No. 2 - Shutoff Valve No. 2

Purpose: To test shutoff valve No. 2 for tightness.

- Step 1** After passing Test No. 1, continue to test No. 2 by closing test cock No. 2.
- Step 2** The indicated pressure differential will decrease slightly. If pressure differential continues to decrease (approaching "zero"), the No. 2 shutoff valve is reported to be "leaking".

NOTICE

A leaking No. 2 shutoff will give a false reading in tests No. 3 and 4.

Test No. 3 - To Test No. 1 Check Valve

Purpose: To test check valve No. 1 for tightness.

Requirements: Valve must be tight against reverse flow under all pressure differentials.

- Step 1** Close needle valve "A" high side (red) and open test cock No. 2.
- Step 2** Close test cock No. 4. Disconnect bypass hose (yellow) at test cock No. 4.
- Step 3** Open needle valve "B" low (blue) and "C" bypass (yellow), bleeding to atmosphere, then closing needle valve "B" (blue) restores the system to a normal static condition.
- Step 4** Observe the pressure differential gauge. If there is a decrease in the indicated value, the No. 1 check valve is reported as "leaking".

Test No. 4 - Pressure Differential Relief Valve

Purpose: To test operation of pressure differential relief valve.

Requirements: The pressure differential relief valve must operate to maintain the "zone" between the two check valves at least 2psi less than the supply pressure.

- Step 1** Close needle valve "C" bypass (yellow).
- Step 2** Open needle valve "A" high side (red).
- Step 3** Open needle valve "B" low (blue) very slowly until the differential gauge needle starts to drop.
- Step 4** Hold the valve at this position and observe the gauge reading at the moment the first discharge is noted from the relief valve. Record this as the opening differential pressure of the relief valve.

NOTICE

It is important that the differential gauge needle drops slowly.

- Step 5** Close test cocks Nos. 2 and 3. Remove hose from test cocks Nos. 2 and 3.
- Step 6** Use bypass hose (yellow) to relieve pressure from test kit by opening needle valve "A", "B" and "C" and bleed valves "A" and "B".
- Step 7** Remove all test equipment and open No. 2 shutoff valve of the device.

CAUTION

To prevent freezing, hold Test Kit vertically to drain differential gauge and hoses prior to placing in case.

For additional testing information, refer to IS-TK-DP/DL, IS-TK-9A, IS-TK-99E or IS-TK-99D.

Servicing First and Second Check Valves 3/4" to 2" (20 to 50mm)

No special tools required to service Series 909/LF909

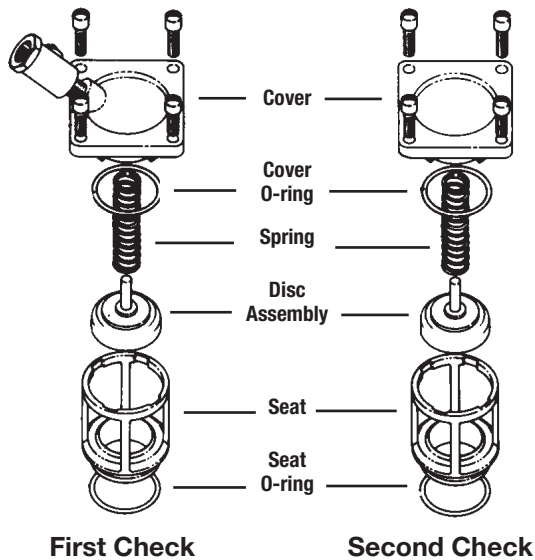
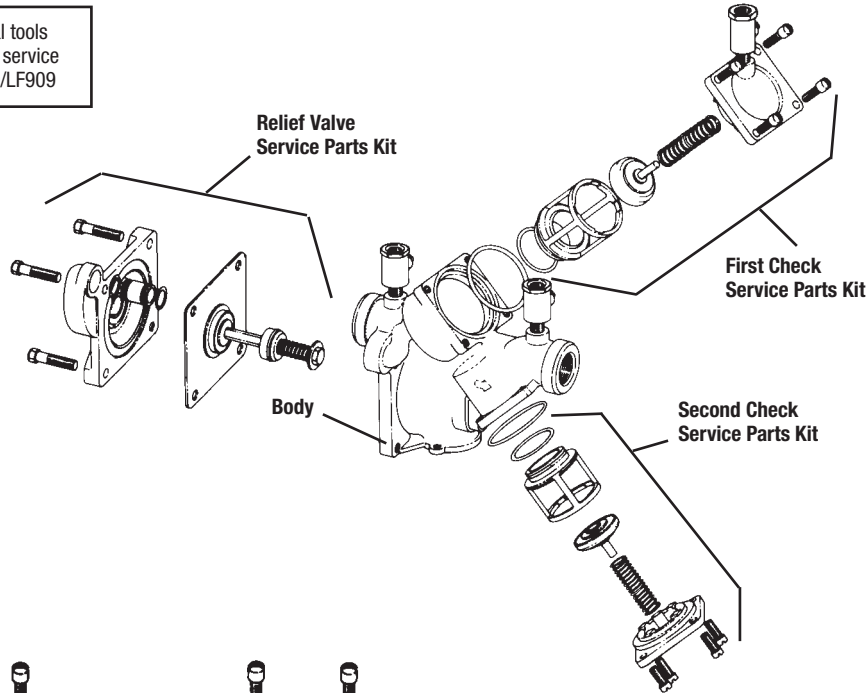

1. Remove the four screws holding the first check valve cover.
2. Lift off the first check valve cover. The check valve inside will come out with the cover and is attached with a bayonet type locking arrangement.
3. Holding the check valve module in both hands, rotate the assembly quarter turn. This will disengage the disc assembly, spring and seat cover into individual components.
4. The disc assembly may be cleaned and reassembled, or depending upon its condition, it may be discarded and replaced with a new assembly from this service kit. O-rings should be cleaned or replaced as necessary and lightly greased with the FDA approved silicon grease which is also furnished with the service kit.
5. Reassemble the check valve module in the reverse order. Service is identical for both the first and second check valves.

For further details contact your local technical sales representative.

NOTICE

The springs and covers of the first and second check valves are **not** interchangeable. The heavier spring loaded module should be in the first check and the lighter in the second check module.

For repair kits and parts, refer to our Backflow Prevention Products Repair Kits & Service Parts price list PL-RP-BPD found on www.watts.com.

Servicing the Relief Valve 3/4" to 2"

1. Remove the four bolts that hold the relief valve cover in place.
2. Remove the cover. The stainless steel adapter, with O-ring attached will be free to be removed simultaneous with the removal of the cover. Pull out the relief valve assembly.

NOTICE

The spring tension in the relief valve assembly is contained in the design of the relief valve; therefore, the relief can be removed in a one-piece spool-type assembly.

3. The relief valve seat and disc may be cleaned without disassembly of the relief valve assembly. If it is determined that the relief valve diaphragm and/or disc should be replaced, the relief valve module can be readily disassembled without the use of special tools.

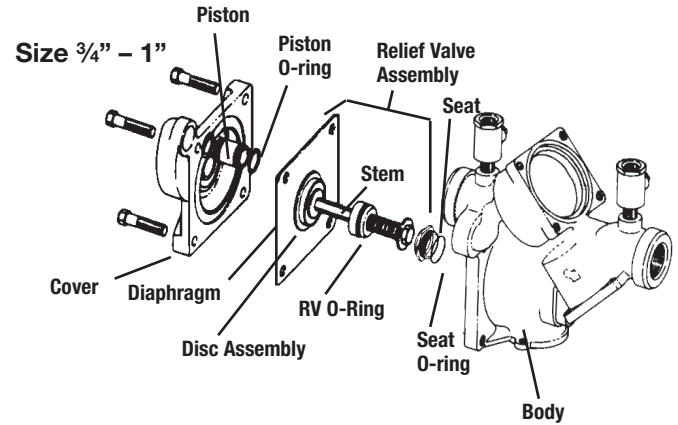

Size 1 1/4" - 2" (32-50mm)

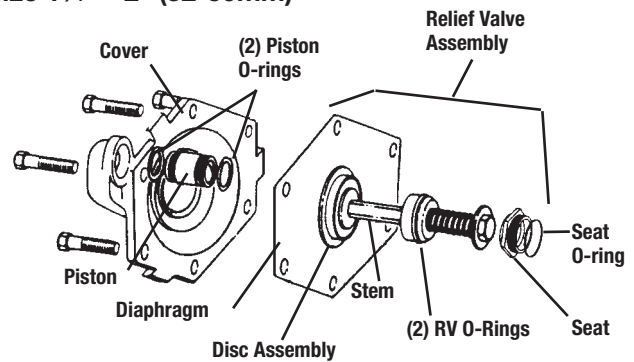

For repair kits and parts, refer to our Backflow Prevention Products Repair Kits & Service Parts price list PL-RP-BPD found on www.watts.com.

For further details contact your local technical sales representative.

To Prevent Shaft Damage Assemble As Shown:

CAUTION

If cover will not press against body, assembly is crooked and tightening bolts will bend shaft. Do not force the cover into place as damage may result from misalignment.

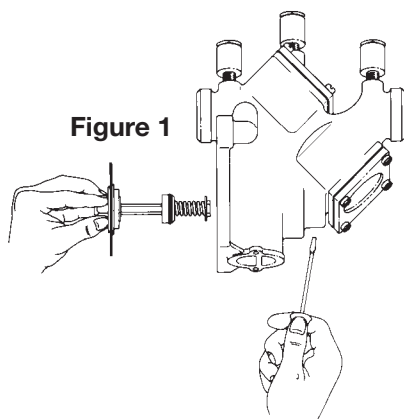

Figure 1:
To assemble the Relief Valve Assembly have a screwdriver ready.

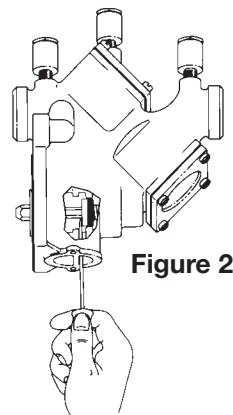

Figure 2:
Depress the Relief Valve Assembly, carefully guiding it against the two pound spring load. When properly aligned, the piston is in the cylinder bore. Insert the screwdriver as shown.

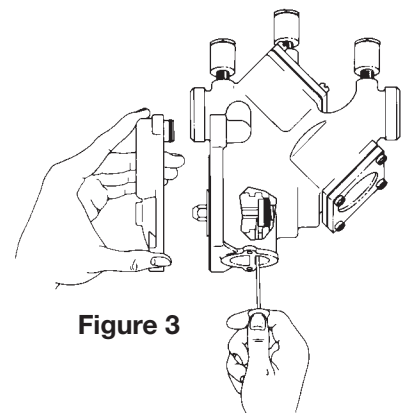

Figure 3:
The Relief Valve Assembly is held encapsulated by the screwdriver. You should now have both hands free to bolt down the cover. Insert and snug two bolts 180° apart to hold the cover. Finish inserting the remaining bolts and snug up evenly, alternating until secure. Remove the screwdriver.

Troubleshooting Guide — Backflow Preventers

Problem	Cause	Solution
A. Valve spits periodically from the vent	A.1 Fluctuating supply pressure.	A.1 Install a soft seated check valve immediately upstream of the device.
	A.2 Fluctuating downstream pressure	A.2 Install a soft seated check valve downstream of the device close as possible to the shutoff valve.
B. Valve drips continually from the vent	B.1 Fouled first check	B.1 Flush valve. If flushing does not resolve problem, disassemble valve and clean or replace the first check.
	B.2 Damage or fouled relief valve seat.	B.2 Clean or replace the relief valve seat.
	B.3 Relief valve piston O-ring not free to move due to pipe scale, dirt or build up of mineral deposits.	B.3 Clean, grease or replace the piston O-ring.
	B.4 Excessive back pressure, freezing, or water hammer has distorted the second check.	B.4 Eliminate source of excessive backpressure or water hammer in the system downstream of the device. Use Watts No. 15 to eliminate water hammer. Replace defective second check assembly. In case of freezing; thaw, disassemble and inspect internal components. Replace as necessary.
	B.5 Electrolysis or relief valve seat or first check seats.	B.5 Replace relief valve seat or inlet cover. Electrically ground the piping system and/or electrically isolate the device with plastic pipe immediately upstream and downstream of the device.
	B.6 Valve improperly reassembled.	B.6 If valve is disassembled during installation, caution must be exercised to install check springs in their proper location.
C. Valve exhibits high pressure drop.	C.1 Fouled strainer.	C.1 Clean strainer element or replace.
	C.2 Valve too small for flows encountered.	C.2 Install proper size device based upon flow requirements.
D. No water flows downstream of valve.	D. Valve installed backwards.	D. Install valve in accordance with flow direction arrow.
E. Valve does not test properly	E.1 Follow manufacturer's test procedure	E.1, E.2 Clean or replace gate valve with full port ball valves or resilient wedge shutoff valves.
	E.2 Leaky downstream gate valve.	
F. Valve quickly and repeatedly fouls following servicing.	F. Debris in pipe line is too fine to be trapped by strainer.	F. Install finer mesh strainer element in the strainer.
G. Winterization of backflow preventers.		G. Electric heat-tape wrap closely together around valve body. Build a small shelter around the valve with a large light bulb installed and left on at all times. If supply line is not used during the winter, removal of the complete body is the best. This would create an air gap to eliminate any possible backflow.

For additional information, visit our web site at: www.watts.com

WARNING: This product contains chemicals known to the State of California to cause cancer and birth defects or other reproductive harm.
For more information: www.watts.com/prop65

Limited Warranty: Watts Regulator Co. (the "Company") warrants each product to be free from defects in material and workmanship under normal usage for a period of one year from the date of original shipment. In the event of such defects within the warranty period, the Company will, at its option, replace or recondition the product without charge.

THE WARRANTY SET FORTH HEREIN IS GIVEN EXPRESSLY AND IS THE ONLY WARRANTY GIVEN BY THE COMPANY WITH RESPECT TO THE PRODUCT. THE COMPANY MAKES NO OTHER WARRANTIES, EXPRESS OR IMPLIED. THE COMPANY HEREBY SPECIFICALLY DISCLAIMS ALL OTHER WARRANTIES, EXPRESS OR IMPLIED, INCLUDING BUT NOT LIMITED TO THE IMPLIED WARRANTIES OF MERCHANTABILITY AND FITNESS FOR A PARTICULAR PURPOSE.

The remedy described in the first paragraph of this warranty shall constitute the sole and exclusive remedy for breach of warranty, and the Company shall not be responsible for any incidental, special or consequential damages, including without limitation, lost profits or the cost of repairing or replacing other property which is damaged if this product does not work properly, other costs resulting from labor charges, delays, vandalism, negligence, fouling caused by foreign material, damage from adverse water conditions, chemical, or any other circumstances over which the Company has no control. This warranty shall be invalidated by any abuse, misuse, misapplication, improper installation or improper maintenance or alteration of the product.

Some States do not allow limitations on how long an implied warranty lasts, and some States do not allow the exclusion or limitation of incidental or consequential damages. Therefore the above limitations may not apply to you. This Limited Warranty gives you specific legal rights, and you may have other rights that vary from State to State. You should consult applicable state laws to determine your rights. **SO FAR AS IS CONSISTENT WITH APPLICABLE STATE LAW, ANY IMPLIED WARRANTIES THAT MAY NOT BE DISCLAIMED, INCLUDING THE IMPLIED WARRANTIES OF MERCHANTABILITY AND FITNESS FOR A PARTICULAR PURPOSE, ARE LIMITED IN DURATION TO ONE YEAR FROM THE DATE OF ORIGINAL SHIPMENT.**



A Watts Water Technologies Company



USA: Tel: (978) 688-1811 • Fax: (978) 794-1848 • www.watts.com

Canada: Tel: (905) 332-4090 • Fax: (905) 332-7068 • www.watts.ca