

INSTALLATION INSTRUCTIONS FOR HIGH EFFICIENCY PANELS

Items:

F-L1X4/40W/8ZZ/D-75
F-L2X2/40W/8ZZ/D-75
F-L2X4/50W/8ZZ/D-75
F-L2X4/75W/8ZZ/D-75

F-L14/32/8ZZ/D/HP-75
F-L22/32/8ZZ/D/HP-75
F-L24/38/8ZZ/D/HP-75
F-L24/60/8ZZ/D/HP-75

IMPORTANT:

READ INSTRUCTIONS CAREFULLY BEFORE INSTALLING. KEEP THESE INSTRUCTIONS FOR FUTURE REFERENCE. Topaz fixtures must be wired in accordance with the National Electrical Code and all applicable local codes. Proper grounding is required for safety. THIS PRODUCT MUST BE INSTALLED IN ACCORDANCE WITH THE APPLICABLE INSTALLATION CODE BY A QUALIFIED ELECTRICIAN WHO IS FAMILIAR WITH THE CONSTRUCTION AND OPERATION OF THE PRODUCT AND THE HAZARDS INVOLVED.



WARNING: RISK OF FIRE OR ELECTRIC SHOCK. Topaz Panel Light installation requires knowledge of luminaires and electrical systems. If not qualified, DO NOT attempt installation. Contact a qualified electrician.

- Turn off electrical power at fuse or circuit breaker box before wiring fixture to the power supply.
- Turn off the power when you perform any maintenance.

WARNING: Risk of fire or electric shock. Suitable for dry and damp locations. Make sure the power is off prior to installation.

WARNING: Risk of fire or electric shock. Suitable for flat T-Grid in insulated or non-insulated ceilings. Access above ceiling required.

WARNING: DO NOT install in unstable, loose or easily breakable surfaces.

WARNING: DO NOT let objects impact or exert force on the surface of the fixture.

Warranty Information:

This product is warranted for 5 years from the date of purchase, based on 10 hours of use per day. If this product does not perform to the specifications supplied on this package, send an email or write to the address below for product return and replacement. This replacement is the sole remedy available. Liability for incidental or consequential damage is expressly excluded. Visit www.topaz-usa.com for full warranty details.

Wiring Diagram (0-10V Dimmable Panel)

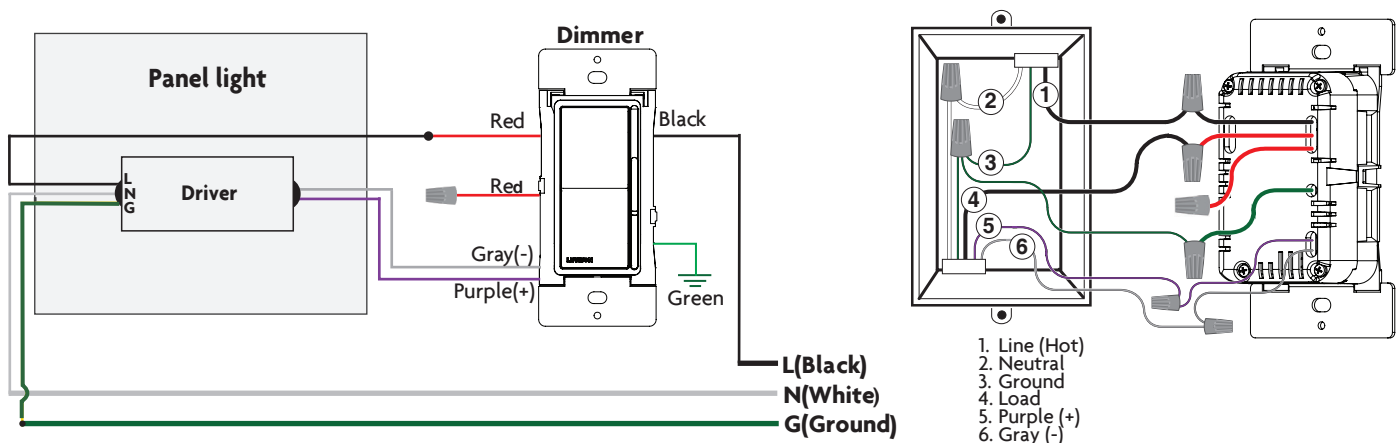

If you have questions regarding these products, call TOPAZ LIGHTING CORP. at 1-800-666-2852 www.topaz-usa.com

INSTALLATION INSTRUCTIONS FOR HIGH EFFICIENCY PANELS

1. Remove the ceiling tile at an appropriate location where the product is to be installed, and raise the product above the bar.

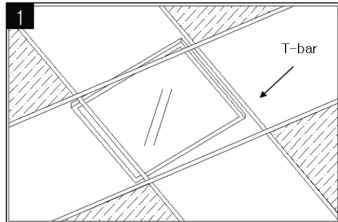

2. Place one end of the product on the T-bar. To secure the luminaire (fixture) position in ceiling, squeeze tabs into T-bars to lock luminaire (fixture).

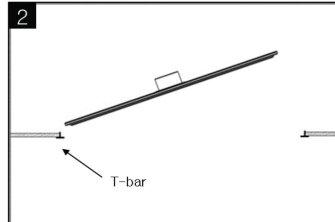

3. With power turned off at the breaker, connect power leads to driver according to wiring diagram.

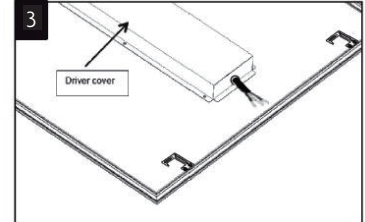

4. Use the protective brackets for safety. After securing the product on the T-bar, secure panel to the ceiling with aircraft cable or wires capable of supporting 100 lbs minimum.

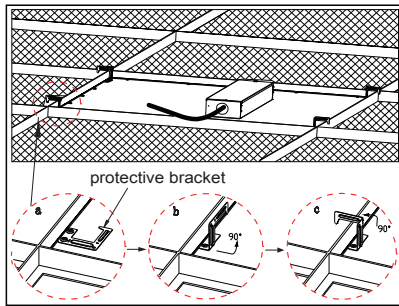

Ceiling Mounting (Mounting kit sold separately)

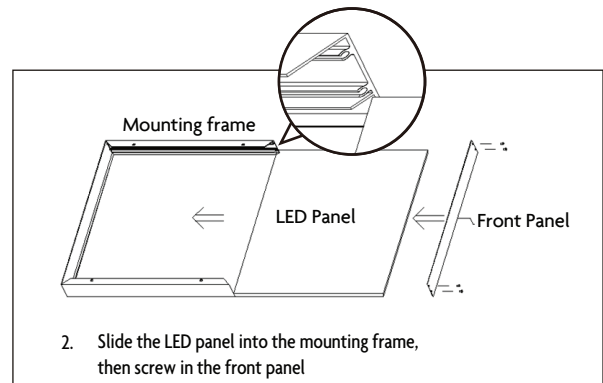
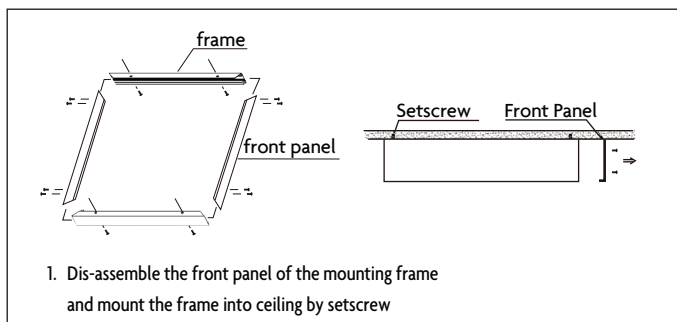

Pendant Mounting (Cable assembly must be purchased separately)

