



Zone Sentry® Zone Valve

The Taco Zone Sentry® Zone Valve enhances the overall performance of any zone valve system. The unique patented technology in the Zone Sentry® utilizes a microcircuit based logic to control a gear driven electronic actuator which drives a ball valve based body design. All this adds up to a zone valve that leads the industry in energy efficiency, flow capacity (C_v), shutoff pressure rating, ease of installation, diagnostic capability and the number of valves (12) that can be use on a standard 40VA transformer. The Taco Zone Sentry® zone valves are available in sweat, threaded and 3-way configurations.



Submittal Data Information Zone Sentry® Ball Valve Zone Valve

Submittal Data # 101-140
Supersedes: 07/28/11

Effective: 06/26/13

Product Specifications

Max. Operating Pressure	300 PSI (2100 kPa)
Max. Shutoff Pressure	125 PSI (875 kPa)
Fluid Temperature Range	20-240°F (7°-115°C)
Service	Water or Water/Glycol up to 50% Glycol (Open System — Option Available)
Ball Rotation Speed	(90° turn), Approximately (after charge time)
Electrical Rating	24 VAC, 60Hz 0.48 Amps
Power Consumption (Charging)	11.4 W, 0.48 Amps
Power Consumption (Power On)	1.44W, 0.06 Amps
Heat Anticipator Setting	0.5 Amps
End Switch Rating	1 Amp @ 24 VAC

Application:

Taco Zone Sentry® Zone Valves provide on-off, normally open or normally closed control in both open and closed hydronic systems. The valves can be used in a wide variety of heating and non condensing cooling applications, primarily designed for use with baseboard, fan coils, radiators, convectors, air handlers, heat pumps and radiant applications.

Ease of Installation / Operation:

The Taco Zone Sentry® is the most technologically advanced zone valve ever made. It's also simple to install and operate. The valve can be installed in any direction, in any orientation. We then went a step further, allowing the operator to be mounted to the 2-way valve body in either direction, great for those tight baseboard jobs. Snap-in quick connects on the back of the valve make for a simple, secure and fast wiring hook-up. A green LED light shows full functionality of the valve's operation and thermostat status. Under a no power situation the manual override button located on the top of the valve allows the ball to be rotated up to 90° and is also marked with a slot to indicate the position of the valve.

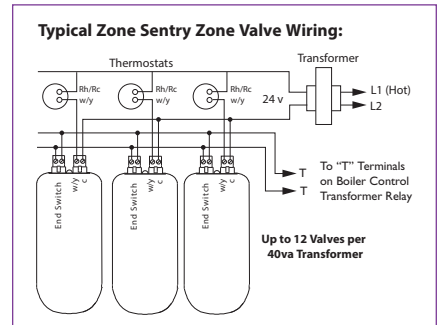

Materials of Construction, Actuator:

Body	High Performance Engineered Polymer
Gears	High Performance Internally Lubricated Engineered Polymer

Materials of Construction, Valve:

Body	Forged Brass
Stem	Brass
Press Ring	Brass
Ball	Brass (Chrome Plated)
Seat	Modified Teflon®
O-Rings	EPDM

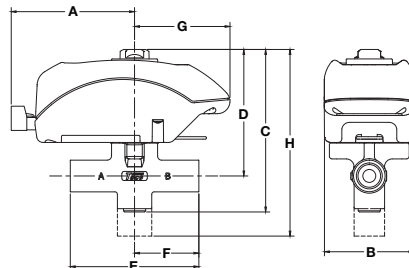

Valve Size	2-WAY Cv (Kv) / Ft. of Pipe Equiv.**	Close-Off Pressure (kPa)	3-WAY Cv (Kv) / Ft. of Pipe Equiv.**
1/2"	4.9 (4.3) / 9.5	0-125 psi (0-862 kPa)	1.5 (1.3) / 111
3/4"	10.3 (8.9) / 8.4	0-125 psi (0-862 kPa)	3.3 (2.8) / 82
1"	8.9 (7.7) / 47.4	0-125 psi (0-862 kPa)	3.0 (2.6) / 411

**At 4' per second (Max. recommended residential flow rate).

Zone Sentry® Dimensions: (FOR REFERENCE PURPOSES)

Valve Size	A		B		C		D		E (Sweat)		E (Threaded)		F		G		H (3-way)	
	in.	mm	in.	mm	in.	mm	in.	mm	in.	mm	in.	mm	in.	mm	in.	mm	in.	mm
1/2"	3"	76.2	2.375"	60.3	4.125"	104.7	3.06"	77.72	3.125"	79.3	4.750"	120.6	1.562"	39.7	2.312"	58.7	5.06"	128.5
3/4"	3"	76.2	2.375"	60.3	4.125"	104.7	3.12"	79.25	3.125"	79.3	3.312"	84.1	1.562"	39.7	2.312"	58.7	5.37"	136.4
1"	3"	76.2	2.375"	60.3	4.125"	104.7	3.12"	79.25	3.875"	98.4	3.875"	98.4	1.875"	47.6	2.312"	58.7	5.50"	139.7

NPT Models	2-Way	Sweat Models
Z050T2	1/2" 2-way	Z050C2
Z075T2	3/4" 2 way	Z075C2
Z100T2	1" 2-way	Z100C2

Consult factory for additional model numbers.



NPT Models	3-Way	Sweat Models
Z050T3	1/2" 3-way	Z050C3
Z075T3	3/4" 3-way	Z075C3
Z100T3	1" 3-way	Z100C3