



TRUE UNION BALL VALVES (REGULAR STYLE)



Sample Engineering Specification

All thermoplastic ball valves shall be True Union type constructed from PVC Type I, ASTM D 1784 Cell Classification 12454 or CPVC Type IV, ASTM D 1784 Cell Classification 23447. All O-rings shall be EPDM or FKM. All valves shall have Safe-T-Shear[®] stem and double stop Polypropylene handle. All valve union nuts shall have Buttress threads. All seal carriers shall be Safe-T-Blocked[®]. All valve components shall be replaceable. All EPDM valves shall be certified by NSF[®] International for use in potable water service. All 1/2" - 2" valves shall be pressure rated at 235 psi and all 2-1/2" - 6" and all flanged valves shall be pressure rated at 150 psi for water at 73°F, as manufactured by Spears[®] Manufacturing Company.

Features – PVC, CPVC

This versatile, quarter-turn shutoff valve is well suited for industrial and chemical processing applications. Available in IPS Sizes 1/2" - 4" with socket, threaded or flanged end connectors. 6" Venturied valve (4" valve with 4 x 6 adapter) available with either socket or flanged end connection. Also available with metric 20mm - 110mm or 1/2" - 4" BSP threaded end connectors.

- Chemical & Corrosion Resistant PVC or CPVC Construction
- Schedule 80 Full-Bore Design
- Strong, Buttress Thread Union Nuts
- Fully Serviceable, Replaceable Components
- Spears[®] Safe-T-Blocked[®] Seal Carrier
- Self Adjusting PTFE Floating Seat Design
- EPDM or FKM O-rings
- High Impact Polypropylene Handle
- Spears[®] Safe-T-Shear[®] Stem Design
- Sizes 1/2" - 2" Pressure Rated to 235 psi @ 73°F, Sizes 2-1/2" - 6" and all flanged Pressure Rated to 150 psi @ 73°F
- EPDM valves NSF[®] Certified for Potable Water use
- Suitable for Vacuum Service
- Assembled with Silicone-Free, Water Soluble Lubricants
- Manufactured to ASTM F 1970

Quick-View Valve Selection Chart

Valve Size	O-ring Material	PVC Part Number ¹			Pressure Rating
		Threaded	Socket	Flanged	
1/2	EPDM	2329-005	included	2323-005	235 psi Non-Shock Water @ 73°F
	FKM	2339-005	included	2333-005	
3/4	EPDM	2329-007	included	2323-007	
	FKM	2339-007	included	2333-007	
1	EPDM	2329-010	included	2323-010	
	FKM	2339-010	included	2333-010	
1-1/4	EPDM	2329-012	included	2323-012	(Flanged 150 psi Non-Shock) Water @ 73°F
	FKM	2339-012	included	2333-012	
1-1/2	EPDM	2329-015	included	2323-015	
	FKM	2339-015	included	2333-015	
2	EPDM	2329-020	included	2323-020	
	FKM	2339-020	included	2333-020	
2-1/2	EPDM	2321-025	2322-025	2323-025	150 psi Non-Shock Water @ 73°F
	FKM	2331-025	2332-025	2333-025	
3	EPDM	2321-030	2322-030	2323-030	
	FKM	2331-030	2332-030	2333-030	
4	EPDM	2321-040	2322-040	2323-040	
	FKM	2331-040	2332-040	2333-040	
6 ² venturied	EPDM	---	2322-060	2323-060	
	FKM	---	2332-060	2333-060	

Optional Accessories*

- Round Safety Handle
- Stem Extension Kit
- 2" Square / T-Style Operator Nut

* See "BALL VALVE ACCESSORIES" section for details of individual products.

1: For CPVC valves, add the letter "C" to part numbers listed (e.g., 2339-005C).

2: Consists of 4" True Union Ball Valve with two 4" x 6" Adapters.

TRUE UNION BALL VALVES (REGULAR STYLE)

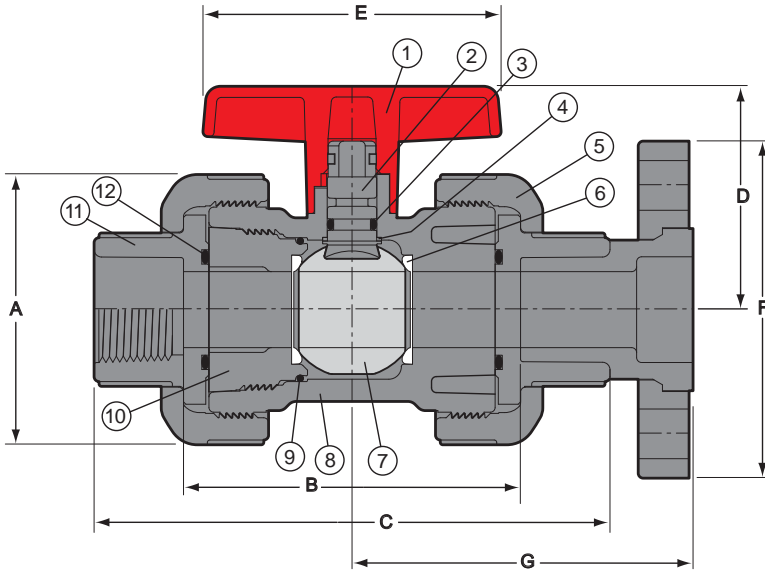

Replacement Parts

No.	Component	Qty.	Material
1	Handle	1	PP
2	Stem	1	PVC/CPVC
3	Stem O-ring	1	EPDM/FKM
4	Stem Bearing*	1	PP
5	Union Nut	2	PVC/CPVC
6	Seat**	2	PTFE
7	Ball	1	PVC/CPVC
8	Body	1	PVC/CPVC
9	Carrier O-ring	1	EPDM/FKM
10	Seal Carrier	1	PVC/CPVC
11	End Connector	2	PVC/CPVC
12	End Connector O-ring	2	EPDM/FKM

* Sizes 1-1/4" and larger.

** Seat O-ring (not shown) on sizes 2-1/2" and larger.

Dimensions, Weights, Operating Torque & Cv Values

Nominal Size	Dimension Reference (inches, ± 1/16)							Approx. Wt. (Lbs.)				Oper. ² Torque (in.-lb.)	C _v ⁴ Values	
	A	B ¹	C	D	E	F	G	PVC		CPVC			Soc/Thd	Flanged
								Soc/Thd	Flanged	Soc/Thd	Flanged			
1/2	2-9/16	3-7/16	5-3/16	2-13/32	2-23/32	3-1/2	3-15/32	1.05	1.23	.95	1.14	20	25	18
3/4	3-1/32	4-1/16	6-3/16	2-5/8	3-3/16	3-7/8	4	1.44	1.64	1.50	1.73	30	51	36
1	3-13/32	4-5/16	6-9/16	2-13/16	3-23/32	4-1/4	4-5/16	1.91	2.22	2.08	2.43	40	97	67
1-1/4	3-11/16	4-1/2	7-1/16	2-31/32	4-1/8	4-5/8	4-19/32	2.38	2.78	2.52	2.91	60	204	142
1-1/2	4-3/8	5-5/16	8-1/32	3-9/32	4-15/32	5	5-9/32	3.63	4.00	3.82	4.26	80	285	201
2	5-3/16	5-13/16	8-13/16	4-13/32	5-1/4	6	5-23/32	5.40	6.14	5.70	6.54	90	540	381
2-1/2	7-7/16	8-3/8	11-7/8	4-29/32	9-7/8	7	7-3/16	12.87	14.26	13.44	15.85	300	712	512
3	7-7/16	8-3/16	11-15/16	4-29/32	9-7/8	7-1/2	7-11/32	13.24	15.67	13.85	16.96	300	1294	925
4	8-15/16	8-11/16	13-3/16	5-19/32	10-13/16	9-1/16	8-5/32	19.58	24.32	20.49	25.83	400	2629	1868
6 Socket ³	8-15/16	19-5/8	26-1/16	6-3/4	10-13/16	11-1/4	14-11/16	22.66	30.98	26.11	34.78	400	N/A	N/A
6 Flanged ³	11-3/16	29-3/8	N/A	6-3/4	10-13/16	11-1/4	14-11/16	N/A	N/A	N/A	N/A	400	N/A	N/A

1: Valve Lay Lengths.

2: Torque required at valve maximum internal pressure rating, 5 ft./sec. flow velocity.

3: Consists of 4" True Union Ball Valve with two 4" x 6" Adapters.

4: Gallons per minute at 1 psi pressure drop. Values calculated from valve laying length, based on derivative of Hazen-Williams equation with surface roughness factor of C=150.

C_v Valves for 6" venturied flange and socket valves are not available.

Temperature Pressure Rating

System Operating Temperature °F (°C)		100 (38)	110 (43)	120 (49)	130 (54)	140 (60)	150 (66)	160 (71)	170 (77)	180 (82)	190 (88)	200 (93)	210 (99)	
Valve Pressure Rating psi (MPa)	1/2" - 2"	PVC	235 (1.62)	211 (1.45)	150 (1.03)	75 (.52)	50 (.34)	-0- (-0-)	-0- (-0-)	-0- (-0-)	-0- (-0-)	-0- (-0-)	-0- (-0-)	
		CPVC	235 (1.62)	219 (1.51)	170 (1.17)	145 (1.00)	130 (.90)	110 (.76)	90 (.62)	80 (.55)	70 (.48)	60 (.41)	50 (.34)	-0- (-0-)
	2-1/2" - 6"	PVC	150 (1.03)	135 (.93)	110 (.76)	75 (.52)	50 (.34)	-0- (-0-)	-0- (-0-)	-0- (-0-)	-0- (-0-)	-0- (-0-)	-0- (-0-)	-0- (-0-)
		CPVC	150 (1.03)	140 (.97)	130 (.90)	120 (.83)	110 (.76)	100 (.70)	90 (.62)	80 (.55)	70 (.48)	60 (.41)	50 (.34)	-0- (-0-)

NOTE: Flanged Valves have a base pressure rating of 150 psi.

NOT FOR DISTRIBUTION OF COMPRESSED AIR OR GASES