

G2 Optima Plus® Flushometer

Sloan introduced its Optima Plus® battery powered sensor flushometer in 1992, revolutionizing the flushing of water closets and urinals. In both new construction and retrofit applications, the use of the Optima Plus has become the standard method for many facilities to improve restroom hygiene and ensure handicap accessibility compliance.

In May, 2003 Sloan introduced the G2 Optima Plus.

The G2 Optima Plus builds on the success of the original product and offers many technological advancements to further improve on performance and reliability expected of sensor activated plumbing. In addition to a new aesthetic design, the G2 Optima Plus features a new state-of-the-art electronic and optical package and a unique solenoid operator that keeps the moving components of the solenoid completely isolated from the water supply. This ensures long life and low maintenance regardless of local water condition.

The G2 Optima Plus replaces the original Optima Plus product, which was phased out of production in mid-2003.

The Sloan G2 Optima Plus automatic battery powered flushometer relies on an infrared sensor to detect a user and activate a flushing cycle. No physical contact with the flushometer surface is necessary, assuring sanitary protection. G2 Optima Plus flushometers are ADA compliant devices.

The flushometer is triggered by means of an active infrared sensor. The Optima Plus sensor emits a continuous invisible light beam. When a user enters the beam's effective range, the beam is reflected into the Optima Plus scanner window. The user is now detected. After the user moves out of the effective range of the sensor, a signal is sent to the flushometer solenoid and, after appropriate arming and/or flush delays, the flush cycle is initiated.

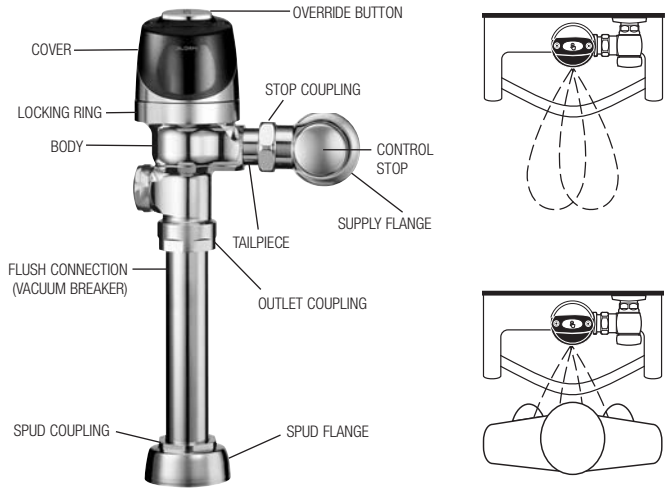

Sensor Flushometers

ITEM 10. FLEX TUBE DIAPHRAGM KIT

Code No.	Part No.	Description	Regulator Color *
3325090	EBV-1025-A	Urinal-0.25 gpf/1.0 Lpf	GREEN
3325003	EBV-1023-A	Urinal-0.5 gpf/1.9 Lpf [†]	GREEN
3325000	EBV-1022-A	Urinal-1.0 gpf/3.8 Lpf	GREEN
3325000	EBV-1022-A	Urinal-1.5 gpf/5.7 Lpf [†]	BLACK
3325001	EBV-1020-A	Urinal-3.5 gpf/13.2 Lpf [†]	WHITE
3325031	EBV-1024-A	Closet-1.28 gpf/4.8 Lpf	GREEN
3325001	EBV-1020-A	Closet-1.6 gpf/6.0 Lpf [†]	GREEN
3325014	EBV-1021-A	Closet-2.4 gpf/9.0 Lpf	BLUE
3325001	EBV-1020-A	Closet-3.5 gpf/13.2 Lpf	WHITE
3325001	EBV-1020-A	Closet-4.5 gpf/17.0 Lpf [§]	WHITE

[†] EBV-1020-A and EBV-1022-A are supplied with multiple regulators.

[‡] A 0.5 gpf (1.9 Lpf) urinal kit can be converted to a 1.0 gpf (3.8 Lpf) by cutting and removing the smooth A-164 flow ring from the guide.

[§] For a 4.5 gpf (17 Lpf) water closet flush use EBV-1020-A with the white regulator, and cut and remove the A-164 flow ring from the guide.

* Color of regulator to be used with flex tube diaphragm to obtain the listed flush volume.

O-RING

Code No.	Part No.	Description
5325056	EBV-83	O-ring – 6 per package

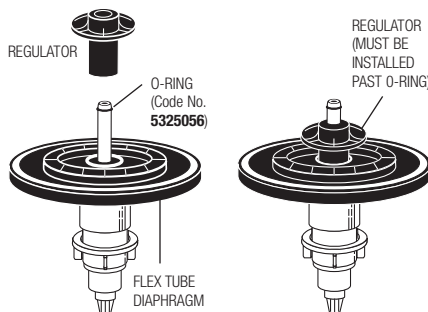

REGULATORS

The flush volume of the flex tube diaphragm kit is controlled by the regulator. Regulators are identified by color. Some flex tube diaphragm kits are supplied with multiple regulators. The installer must make sure the proper regulator is used when installing the flex tube diaphragm kit.

REGULATOR (SOLD 6 PER PACKAGE)

Code No.	Part No.	Description	Regulator Color
5325122	EBV-95	Urinal-0.25 gpf/1.0 Lpf	GREEN
5325122	EBV-95	Urinal-0.5 gpf/1.9 Lpf	GREEN
5325122	EBV-95	Urinal-1.0 gpf/3.8 Lpf	GREEN
5325129	EBV-102-2	Urinal-1.5 gpf/5.7 Lpf	BLACK
5325130	EBV-102-1	Urinal-3.5 gpf/13.2 Lpf	WHITE
5325122	EBV-95	Closet-1.28 gpf/4.8 Lpf	GREEN
5325122	EBV-95	Closet-1.6 gpf/6.0 Lpf	GREEN
5325130	EBV-102-1	Closet-3.5 gpf/13.2 Lpf	WHITE
5325128	EBV-101	Closet-2.4 gpf/9.0 Lpf	BLUE

EBV-1020-A and EBV-1022-A are supplied with multiple flush volume regulators. The installer must use the correct regulator when installing the kit.

ITEM 16A. SLIP JOINT GASKETS AND RINGS

Size	Code No.	Part No.	Description
1-1/2"	5306058	F-3	Red Friction Ring
	5322001	VBF-5	Black Slip Joint Gasket
	0319086/5319086	S-30	Flexible Seat
1-1/2" x 1-1/4"	0319079	S-21	Rigid Seat (rubber over brass)
	0396062	F-105	Slip Joint Gasket – Rigid
1-1/4"	5306057	F-3	Red Friction Ring
	5322176	VBF-5	Black Slip Joint Gasket
	0307052/5307052	G-21	Rigid Seat (rubber over brass)
1"	5306056	F-3	Red Friction Ring
	5306115	F-5	Black Slip Joint Gasket
3/4"	5306055	F-3	Red Friction Ring
	5306113	F-5	Black Slip Joint Gasket