

Instructions

August, 2012
Supersedes Issue of
August, 2003

E87010-A0046-T003-A3-49SA

START-STOP Push Button
Class 14, 17, 18, 36,
37, 40, 83, & 84
Cat. No. 49SAP05

IMPORTANT
THESE INSTRUCTIONS DO NOT PURPORT TO COVER ALL DETAILS OR VARIATIONS IN EQUIPMENT, NOR TO PROVIDE FOR EVERY POSSIBLE CONTINGENCY TO BE MET IN CONNECTION WITH INSTALLATION, OPERATION OR MAINTENANCE. SHOULD FURTHER INFORMATION BE DESIRED OR SHOULD PARTICULAR PROBLEMS ARISE WHICH ARE NOT COVERED SUFFICIENTLY FOR THE PURCHASER'S PURPOSES, THE MATTER SHOULD BE REFERRED TO THE LOCAL SIEMENS SALES OFFICE.
THE CONTENTS OF THIS INSTRUCTION MANUAL SHALL NOT BECOME PART OF OR MODIFY ANY PRIOR OR EXISTING AGREEMENT, COMMITMENT OR RELATIONSHIP. THE SALES CONTRACT CONTAINS THE ENTIRE OBLIGATION OF SIEMENS. THE WARRANTY CONTAINED IN THE CONTRACT BETWEEN THE PARTIES IS THE SOLE WARRANTY OF SIEMENS. ANY STATEMENTS CONTAINED HEREIN DO NOT CREATE NEW WARRANTIES OR MODIFY THE EXISTING WARRANTY.

 Certified when knockouts for mounting of the control stations are provided

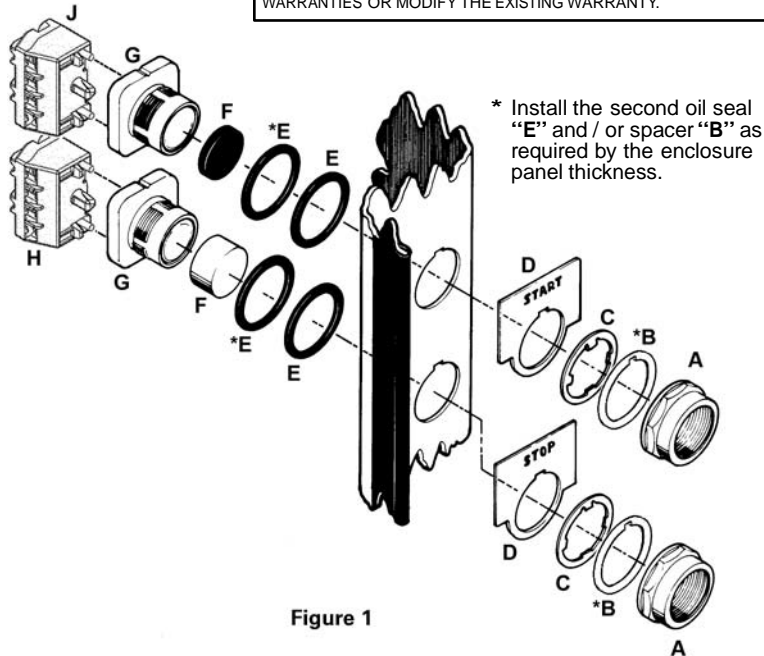

Figure 1

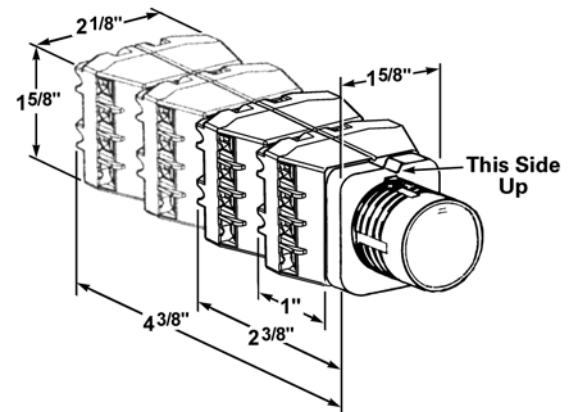

Figure 2

DESCRIPTION

This momentary contact push button kit provides a START-STOP 3-wire control for use with the starters and contactors mounted in enclosures, as noted below. The two oil tight push button operators are individually installed on the enclosure. Each operator accommodates mounting up to eight Furnas Class 52 contact blocks (NEMA A600 rating).

The flange of the standard width and extra wide enclosure for Class 17 and 18 control units contains 2 hole plugs and 1 punch mark for pilot control mounting. The hole plugs are gasketed for proper sealing and are easily removed by loosening the wing nut retainer on the back side. The push button operators for Class 17 and 18 horizontal and column width enclosures and for other control unit classes are mounted on the enclosure door.

Use with the class and size control units mounted in NEMA type enclosures, as follows:

Furnas Class Number	Control Sizes	NEMA Type Enclosure
14, 40	00 through 3 1/2	3, 4, 12
14, 40	4 through 6	1, 3, 4, 12
17, 18, 36 37, 83, 84	(All sizes)	1, 4, 12

Contents of kit, catalog NO 49SAP05:

The START-STOP push button kit consists of two Class 52 push button operators with legend plates, two push button caps and two prewired contact blocks as follows:

- 2 A lock nuts
- 2 B trim ring spacers
- 2 C index locking rings
- 2 D legend plates (1 STOP, 1 START)
- 4 E oil seals
- 2 F push button caps (1 flush black and 1 raised red assembled to H)
- 2 G operator bases
- 1 H normally closed contact block (catalog number 52BAJ for the STOP push button).
- 1 J normally open contact block (catalog number 52BAK for the START push button).



WARNING
Hazardous voltage.
Can cause death, serious personal injury, or property damage.
Disconnect power before working on this equipment.



CAUTION
Maintain 1/2 inch minimum clearance through air between uninsulated live parts, such as contact block terminals and enclosure.

INSTALLATION

A maximum of 8 Furnas Class 52 contact blocks can be used with each operator; arrange blocks not to exceed four levels. Check enclosure depth for adequate space and the 1/2 inch air clearance noted in the warning. Figure 2 shows dimensions (in inches) of the operator base with contact blocks. The contact blocks may be attached to the operator base before or after installing the push button operator. Mounting the contact blocks first avoids the problem of limited access in an enclosure.

Mounting Holes

1. Determine the mounting locations for the two push button operators.
 - a. For flange mounted pilot controls, select two of the pilot control mounting locations (hole plugs or punch marks).
 - b. For door mounted pilot controls, refer to appropriate drawings or the enclosure for suitable locations.
 - c. Mounting hole dimensions are shown in Figure 1. The operators require mounting on 2 1/4 inch minimum centers.
2. Make two mounting holes in the enclosure.
 - a. For the Class 17 or 18 control unit, remove the two hole plugs at the selected locations.
 - b. To cut a 1 7/32 inch diameter hole, use a punch such as Greenlee Knock-out Punch number 730-S. Then use a keyway punch, such as Greenlee number 730-K or 720, to cut the keyway. The keyway should be at the top of the hole for proper alignment of the legend plate.

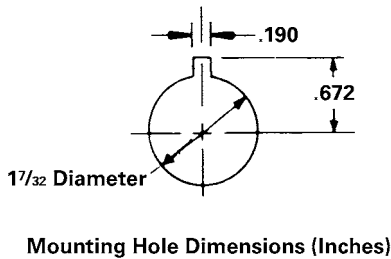

Figure 3

Mounting Push Button Operator

Using wrench catalog number 52MAWA or 52MAWB facilitates assembly and prevents scoring of the lock nuts, **A** however, neither tool is required for installation.

Mount each push button operator as follows:

1. Remove lock nut **A**, from each operator base **H**.
2. Mount each operator base **H** in enclosure as shown in Figure 1 and tighten to 15 ft. lbs.

Wiring Push Buttons

Connect the wires to the starter as follows:

- Red Wire:** Connect to L1. For starters supplied with transformers connect to terminal on secondary fuse block.
- Black Wire:** Connect to bottom terminal (2) on the auxiliary interlock.
- Yellow Wire:** Connect to top terminal (3) on the auxiliary interlock.

