

# Table of Contents

Introduction .....	2
Residential Power Distribution .....	4
Load Centers .....	6
Load Center Construction .....	8
Residential Circuit Breakers .....	16
Ground Fault Protection .....	23
Arc Fault Protection .....	25
Surge Protection .....	30
Load Center Mains .....	34
Load Center Interrupting Ratings .....	37
Service Entrance Equipment Load Centers .....	40
Power Supply Systems .....	41
Load Center Grounding .....	44
PL Series Load Centers .....	46
ES Series Load Centers .....	48
Siemens EQ Load Centers .....	50
Generator Ready Load Centers .....	53
Riser Panel Load Centers .....	54
Load Center Catalog Numbers .....	55
Sizing The Load Center .....	57
AC Disconnects .....	66
Residential Metering .....	67
Review Answers .....	71
Final Exam .....	72

# Introduction

Welcome to another course in the STEP series, **Siemens Technical Education Program**, designed to prepare our distributors to sell Siemens Industry, Inc. products more effectively. This course covers **Basics of Load Centers** and related products.

Upon completion of **Basics of Load Centers** you should be able to:

- Explain the role of a load center in residential power distribution
- Define the term load center
- Distinguish between the terms panelboard and load center
- Explain the need for circuit protection
- Identify various components of a load center
- Distinguish between a main breaker and a main lug only load center
- Identify various power supply systems used in residential applications
- Explain the use of load centers as service entrance equipment
- Describe the proper grounding techniques of service entrance and downstream load centers
- Identify the types of circuit breakers used in Siemens load centers
- Identify Siemens load center products and their features

This knowledge will help you better understand customer applications. In addition, you will be able to describe products to customers and determine important differences between products. You should complete **Basics of Electricity** before attempting **Basics of Load Center**. An understanding of many of the concepts covered in **Basics of Electricity** is required for **Basics of Load Centers**.

After you have completed this course, if you wish to determine how well you have retained the information covered, you can complete a final exam online as described later in this course. If you pass the exam, you will be given the opportunity to print a certificate of completion from your computer.

Siemens is a trademark of Siemens AG. Product names mentioned may be trademarks or registered trademarks of their respective companies. Specifications are subject to change without notice.

NFPA70<sup>®</sup>, National Electrical Code<sup>®</sup>, and NEC<sup>®</sup> are registered trademarks of the National Fire Protection Association<sup>®</sup>, Quincy, MA 02169.

NEMA<sup>®</sup> is a registered trademark and service mark of the National Electrical Manufacturers Association, Rosslyn, VA 22209.

Underwriters Laboratories Inc.<sup>®</sup> and UL<sup>®</sup> are registered trademarks of Underwriters Laboratories Inc., Northbrook, IL 60062-2096.

Other trademarks are the property of their respective owners.

# Residential Power Distribution

A **power distribution system** distributes electrical power throughout a building. Power distribution systems are used in every residential, commercial, and industrial building.

## Residential Distribution

Most of us are familiar with the power distribution system found in the average home. Power, purchased from a utility company, enters the house through a meter that records the electrical energy used.

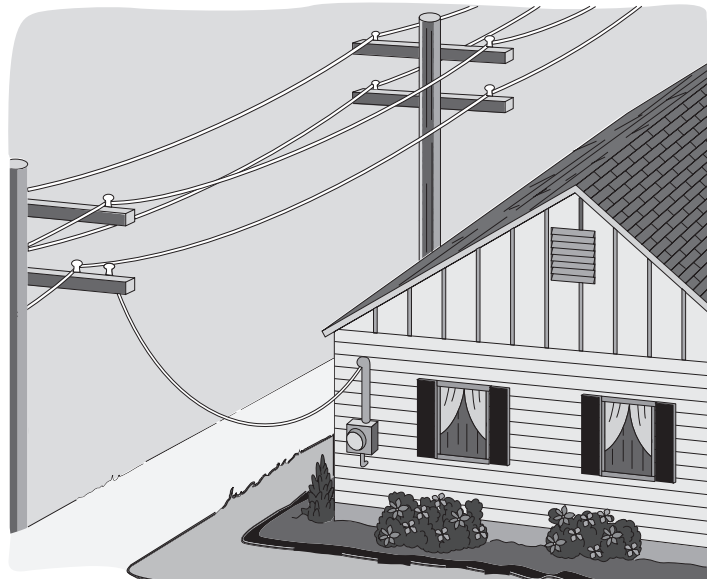

The incoming power then usually goes to a **load center** which provides circuit control and overcurrent protection. The power is distributed from the load center to various branch circuits for lighting, appliances, and electrical outlets.

Sometimes, particularly when there has been additional construction, a second load center, sometimes called a **subpanel**, may be installed and powered from the main load center.

Careful planning is required so that the power distribution system safely and efficiently supplies adequate electric service for present and possible future needs.

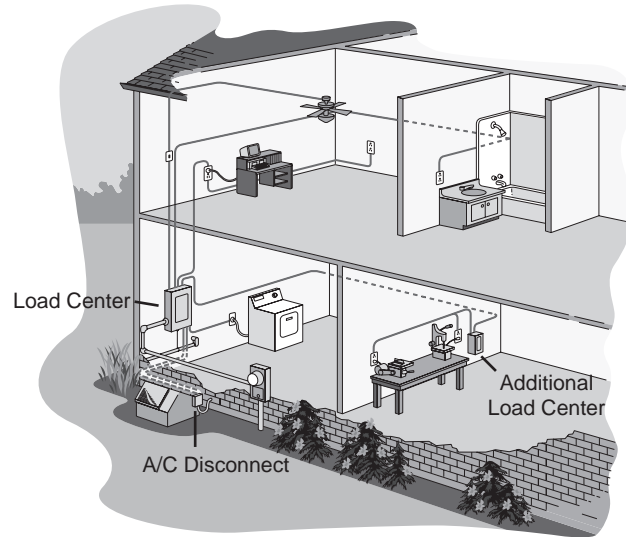

**The National Electrical Code®**

The *National Electrical Code*® (*NEC*®) is used extensively in the electrical industry. Article 408 covers panelboards. Other articles shown in the following illustration cover related topics.

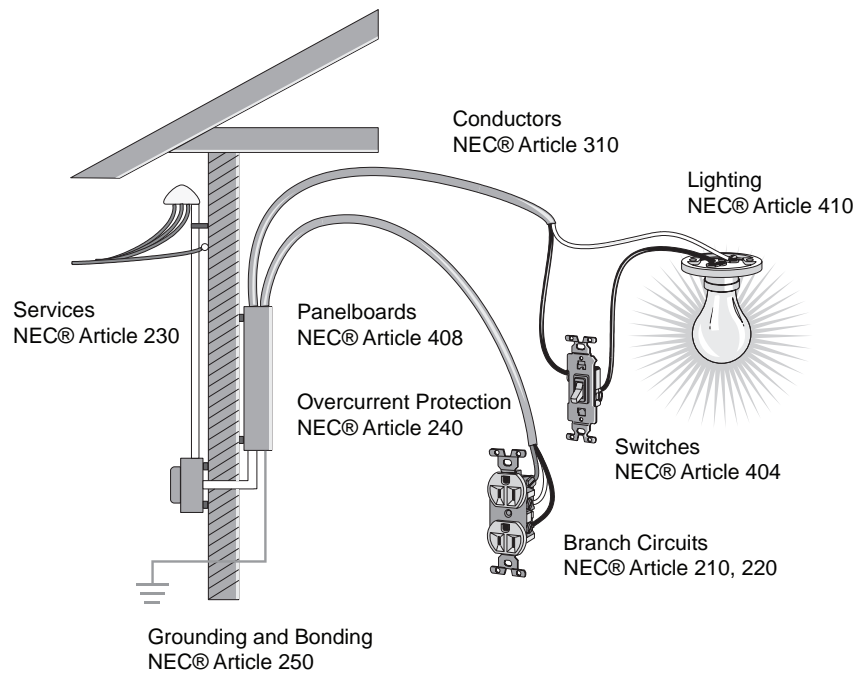

# Load Centers

**Load center** is an industry term that applies to the types of **panelboards** used in residential and light commercial applications. The *National Electrical Code*® makes no distinction between a panelboard and a load center; therefore, rules and definitions that apply to panelboards also apply to load centers.

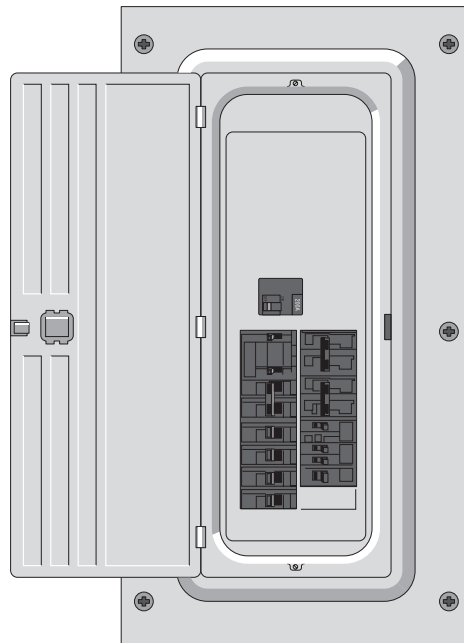

## Definition

A panelboard is a type of enclosure for overcurrent protection devices and the busses and connections that provide power to these devices and their associated circuits.

According to the National Electrical Code® (NEC®), panelboards, including load centers, are:

- Used to control light, heat, or power circuits
- Placed in a cabinet or cutout box
- Mounted in or against a wall
- Accessible only from the front

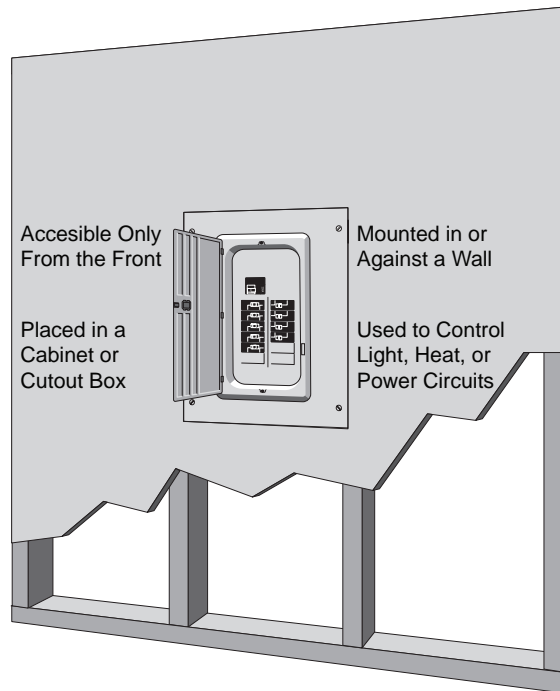

## Review 1

1. A \_\_\_\_\_ system distributes electrical power throughout a building.
2. *NEC*<sup>®</sup> Article \_\_\_\_\_ covers panelboards, including load centers.
3. Overcurrent protection is covered by *NEC*<sup>®</sup> Article \_\_\_\_.
4. The *National Electrical Code*<sup>®</sup> makes no distinction between a panelboard and a load center.
  - a. True
  - b. False
5. Which of the following statements does not meet the *NEC*<sup>®</sup> definition of a panelboard.
  - a. Used to control light, heat, or power circuits
  - b. Placed in a cabinet or cutout box
  - c. Accessible from the front
  - d. Accessible from the rear
  - e. Mounted in or against a wall

# Load Center Construction

Load centers are constructed from the following three parts: **enclosure**, **interior**, and **trim**.

## Enclosure

The **enclosure** is typically constructed of cold rolled steel (for indoor use) or galvanized steel (for outdoor use). Together with the trim, the enclosure is designed to provide component and personnel protection.

The **National Electrical Manufacturers Association (NEMA®)** has established standards for electrical equipment enclosures. **NEMA type 1 enclosures** are intended for indoor use. **NEMA type 3R enclosures** are intended for outdoor use primarily to provide a degree of protection against rain, sleet and damage from external ice formation. Load center enclosures typically conform to one of these NEMA enclosure types.

**Knockouts** are stamped into the enclosure to provide a convenient means of creating holes for use in routing electrical wiring. Approved cable clamps or conduit hubs are used in the holes to secure and protect the cable and conductors.

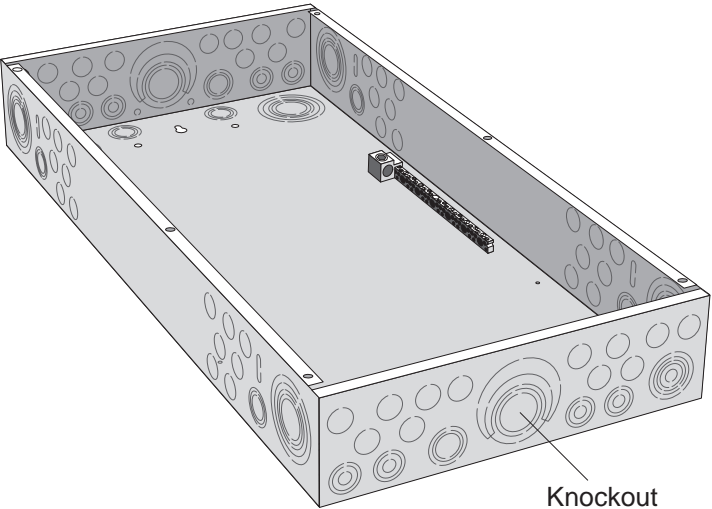



## Removing Knockouts

Knockouts may be removed prior to mounting the enclosure. When there are multiple ring knockouts, remove the center section by striking at the point furthest from the tie. Then, bend the knockout back and forth to break the tie. If a larger opening is required, remove each additional ring, one at a time, by prying with a screwdriver and bending the ring back and forth with pliers as shown in the following figure.

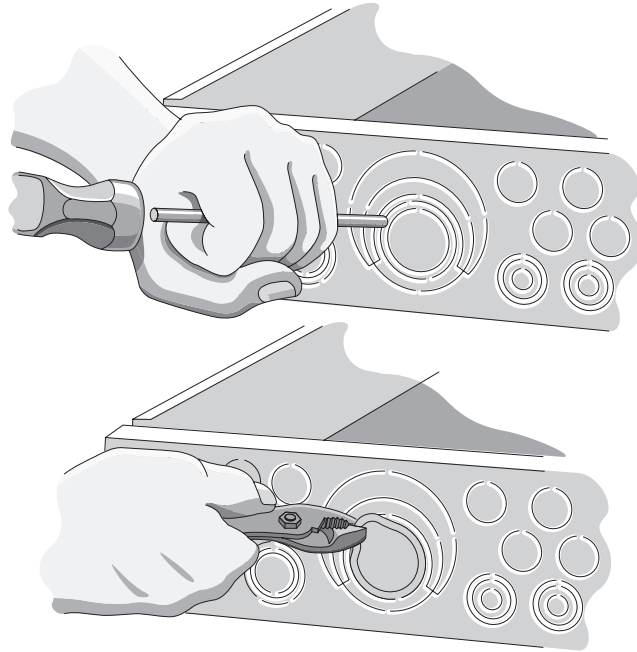

## Interior

The load center **interior** mounts inside the enclosure and includes bus bars and related hardware.

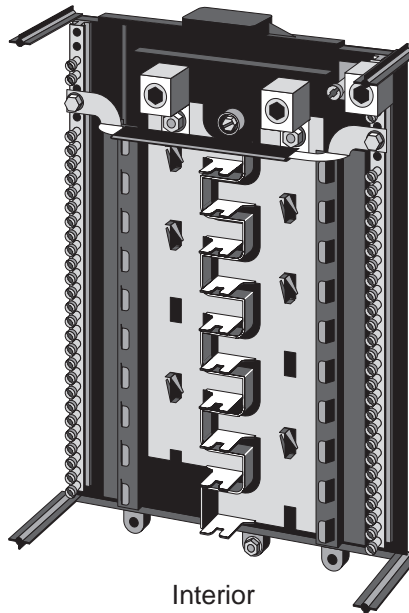

## Bus Bars

A **bus bar** serves as a common connection for two or more circuits. In a load center, bus bars are used to make it easy to connect circuit breakers to service conductors and load wiring. Siemens load center bus bars are made of copper or aluminum.

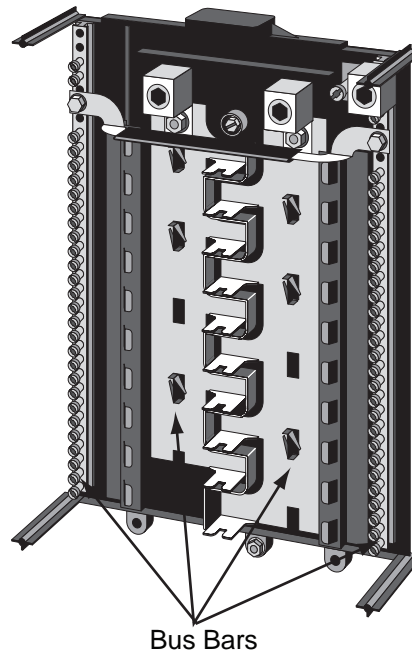

## Power Source

The most common method for powering a load center is to connect the load center's supply bus bars to the secondary winding of the utility transformer. Even though the secondary winding is providing single-phase power, one side of the secondary is called the A phase and the other side is called the B phase. The center tap connection to this transformer is grounded and becomes the neutral connection. The neutral is a current carrying conductor that connects to the load center's neutral bus.

As the following illustration shows, with this configuration, the voltage applied to the load center's supply bus bars is 240 volts, but the voltage from the neutral connection to either supply bus bar is 120 volts.

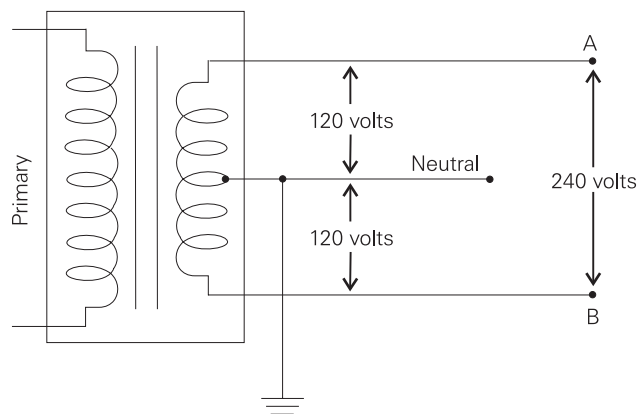

## Split Neutral

Siemens PL series and some Siemens ES series load centers have **dual neutrals**, meaning that neutral connections are available on both sides of the load center interior. Dual neutrals are connected together through a neutral tie bar. Dual neutrals are useful, especially on larger load centers, because they simplify load center wiring.

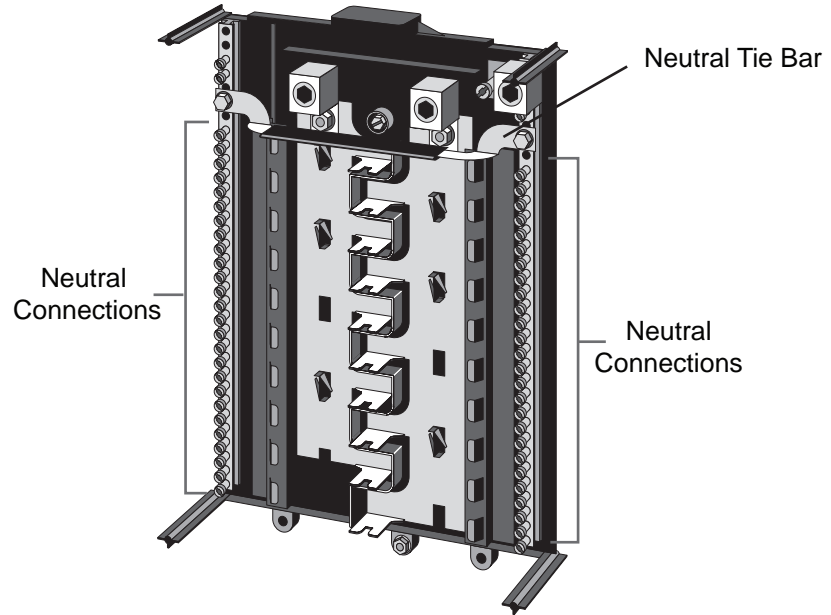

## Insta-wire

**Insta-wire** is a feature found in Siemens PL series and ES series load centers. The Insta-wire screw is a backed-out at the factory, but retained in place by a special feature on the screw thread. This special feature prevents the screw from falling out during shipment or installation. The Insta-wire screw head accepts either a standard screwdriver or a square tool bit.

Insta-wire saves an installer time by eliminating the need to back out every screw and by allowing the installer to use a power tool to tighten screws.

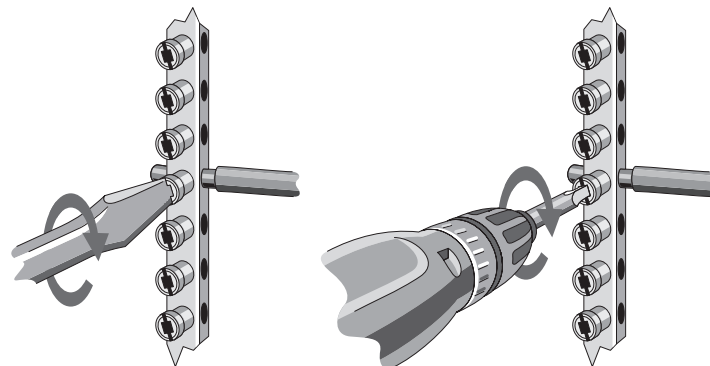

# Branch Circuit Breakers

Branch circuit breakers plug directly onto the load center's supply bus bars as shown in the following illustration.

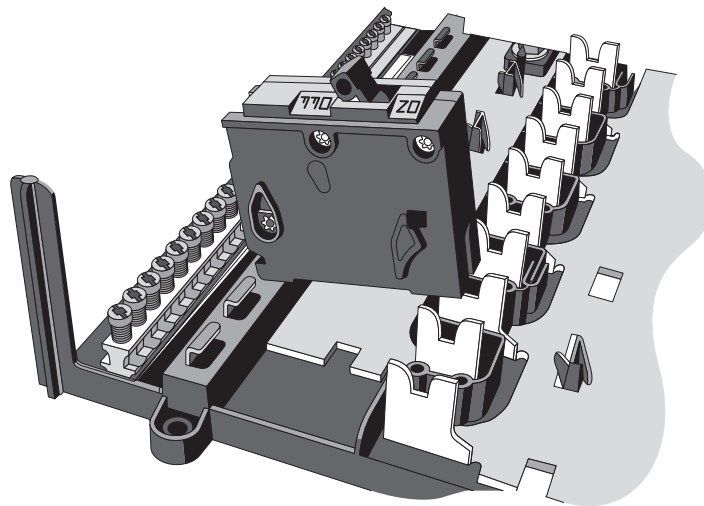

# Label

The **label** identifies the load center's catalog number, enclosure type, voltage service and ampere rating. Additional information on the label identifies circuit breaker types that can be used with the load center, short circuit current ratings, and wiring diagrams.

**SIEMENS** Indoor Load Center

Catalog Number P3040B1200CU Series - Enclosure Type 1  
P3040L1200CU

Ratings  
200A MAXIMUM - 200A MAIN BREAKER RATING IF USED.  
120/240 V • 60 HZ, 1Ø3W

SUITABLE FOR USE AS SERVICE EQUIPMENT WHEN MAIN BREAKER IS INSTALLED.

**SHORT CIRCUIT CURRENT RATING**

Main Breaker	Feeder, Main Breaker	Panelboard Mains	Branch Breakers

USE COPPER OR ALUMINUM 60°/75°C WIRE

## Trim Assembly

The **trim assembly**, sometimes called a dead front, attaches to the front of the load center and covers the interior. The trim assembly includes an access door and an adjustable upper pan. The trim assembly provides access to the circuit breakers while sealing off live parts and internal wiring.

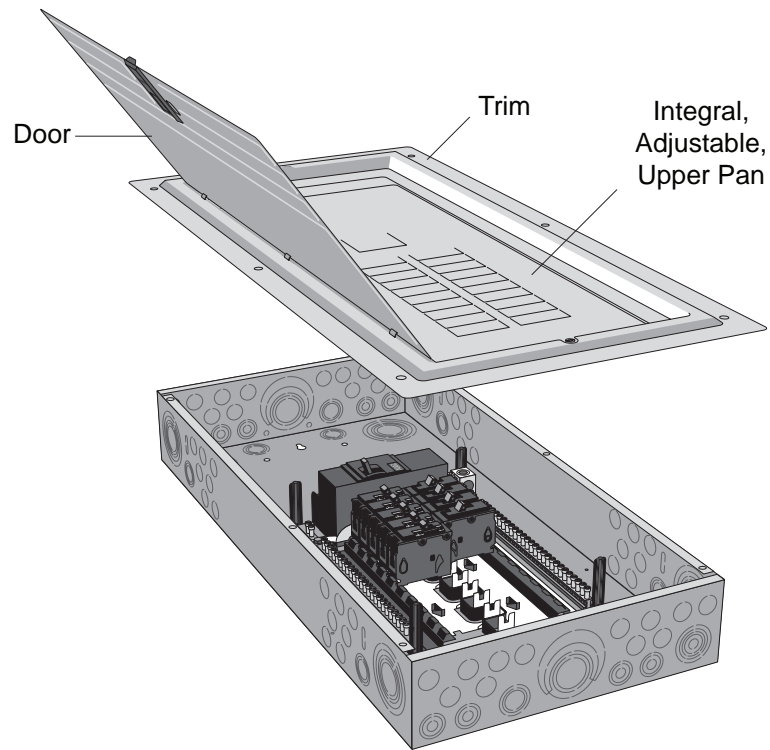

## Twistouts

Part of the upper pan contains **twistouts**. These are used to cover any unused pole spaces not filled by a circuit breaker. Twistouts are removed by an up and down twisting motion with pliers. All unused openings in the upper pan must be filled with a filler plate.



## Circuit Directory

A **circuit directory** on the door, similar to one shown below, provides space for listing the services protected by each branch circuit breaker.

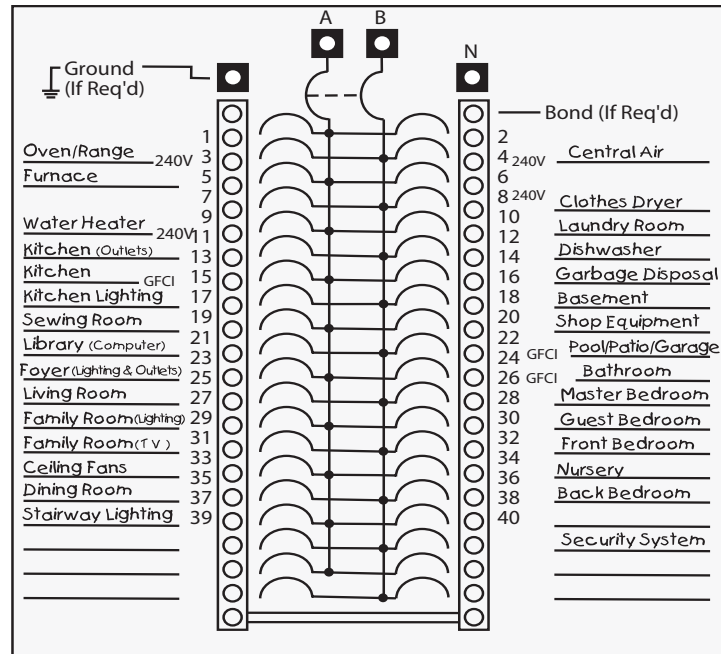

## Load Center Installation

The enclosure, with the interior, is mounted to a wall. All incoming and outgoing conductors are connected to the load center.

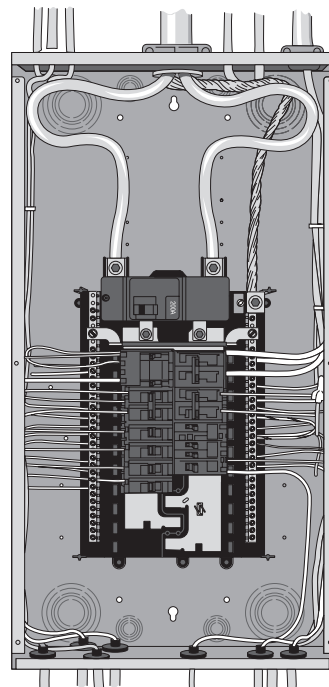

Siemens load centers can be surface or flush mounted. For flush mounting, the load center is positioned so that the front edge of the enclosure is flush with the finished wall. The trim assembly is installed after the wall is finished.

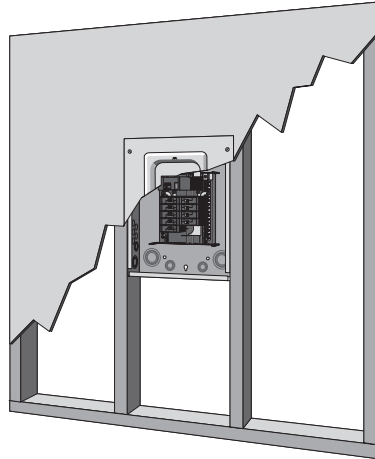

## **NEC® Article 110.26**

Load center installation requires careful planning to ensure a safe environment for personnel and equipment. Article 110.26 of the *National Electrical Code*® covers spaces about electrical equipment. The intent of Article 110.26 is to provide enough working space for personnel to examine, adjust, service, and maintain energized equipment.

## **Review 2**

1. The two types of NEMA enclosures available for Siemens load centers are NEMA type \_\_\_\_ and type \_\_\_\_ .
2. \_\_\_\_\_ circuit breakers plug directly onto the load center's supply bus bars.
3. \_\_\_\_\_ provide neutral connections on both sides of the load center interior.
4. \_\_\_\_\_ is a time saving installation feature where screws are backed out, but retained in place to prevent the screws from falling out.
5. The \_\_\_\_\_ assembly provides access to the load center's circuit breakers while sealing off the bus bars and internal wiring from contact.
6. A \_\_\_\_\_ provides space for listing the services protected by each branch circuit breaker.

# Residential Circuit Breakers

Current flow in a conductor always generates heat. The greater the current flow, the hotter the conductor. Excess heat is damaging to electrical components. For that reason, conductors have a rated continuous current carrying capacity or **ampacity**.

Excessive current is referred to as **overcurrent**. An overcurrent may result from a **short circuit, overload, or ground fault**. Load centers use circuit breakers to provide protection against short circuits and overloads. Most residential circuit breakers do not provide ground fault protection.

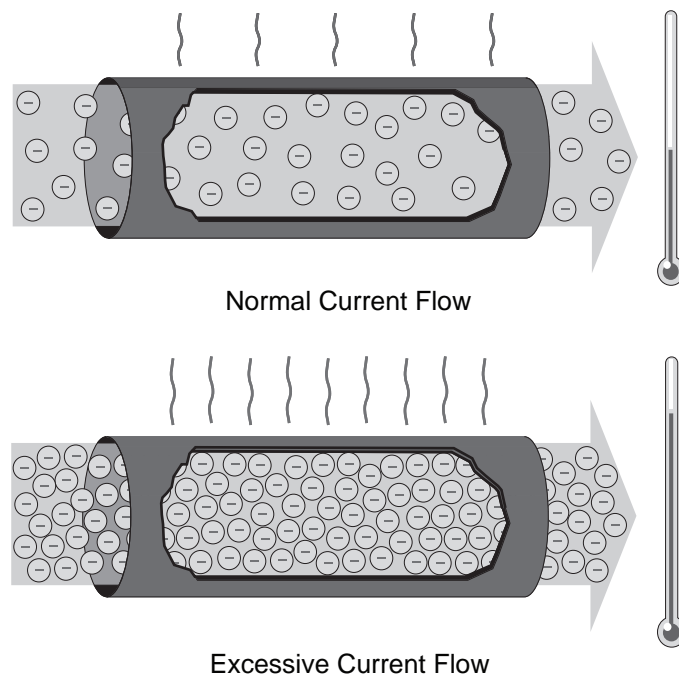

A short circuit occurs when two bare conductors touch, causing the resistance between the conductors at that point to drop significantly. This reduction in resistance causes current to rise quickly.

An overload is typically a much lower current than a short circuit. An overload occurs when too many devices are connected to a circuit or when electrical equipment is made to work beyond its rated capabilities.



## Circuit Breakers

Circuit breakers provide a manual means of energizing and de-energizing a circuit and automatic overcurrent protection for that circuit. Unlike fuses, which must be replaced when they open, a circuit breaker can be reset once the overcurrent condition has been corrected. A simple push of the handle to the "OFF" then back to the "ON" position restores the circuit. If a circuit reopens upon reset to the "ON" position, a qualified electrician should be consulted to determine the problem.

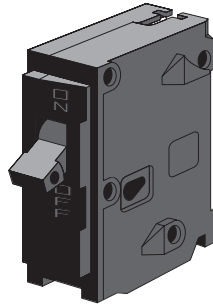

Circuit Breaker

Circuit protection would be unnecessary if overloads and short circuits could be eliminated. Unfortunately, overloads and short circuits do occur. To protect a circuit against these currents, a circuit breaker must determine when a fault condition develops and automatically disconnect the electrical equipment from the voltage source. Slight overloads can be allowed to continue for a short time, but as the current magnitude increases, the circuit breaker must open faster. Short circuits must be interrupted instantly.

## Circuit Breaker Poles

A circuit breaker's **pole** number indicates the number of circuits which supply current through the circuit breaker. For example, a 1-pole circuit breaker carries the current for one circuit and a 2-pole circuit breaker carries the current for two circuits simultaneously. In a 2-pole circuit breaker, both circuits are controlled by the same trip unit so that both poles open at the same time when an overcurrent occurs. In addition, both circuits are mechanically interlocked so that they can be manually opened or closed at the same time.

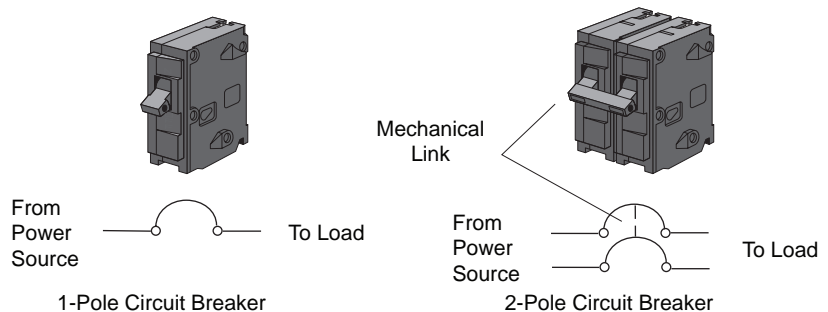

### **Circuit Breaker Ampere Rating**

Every circuit breaker has ampere, voltage, and interrupting ratings. The **ampere rating** defines the maximum continuous current a circuit breaker can carry without tripping. Because the function of the circuit breaker is to protect circuit conductors, the appropriate ampere rating for a circuit breaker is dependent upon the ampacity of the conductors in a circuit.

### **Circuit Breaker Voltage Rating**

Each circuit breaker also has a **voltage rating**, which indicates the maximum voltage it can handle. In other words, the voltage rating of a circuit breaker must be at least equal to the circuit voltage. Some circuit breakers have what is referred to as a "slash" voltage rating, such as 120/240 volts. In such cases, the breaker may be applied in a circuit where the nominal voltage between any conductor and ground does not exceed the lower rating and the nominal voltage between conductors does not exceed the higher rating.

In residential applications, the most common power distribution system is the 1-phase, 3-wire system described later in this course. In these applications, a 1-pole branch circuit breaker protects a 120 volt branch circuit and a 2-pole branch circuit breaker protects a 240 volt branch circuit.

### **Circuit Breaker Interrupting Rating**

A circuit breaker's **interrupting rating** is the maximum available fault current which the breaker is designed to interrupt.

### **Residential Circuit Breakers**

Residential circuit breakers are typically 1, 2, or 4-pole breakers with current ratings of 225 amps or less and voltage ratings of 120 volts, 120/240 volts, or 240 volts. Because residential circuit breakers are also used in commercial applications and many commercial applications require 3-pole breakers, some 3-pole breakers are also included in this category. The most common interrupting rating for residential circuit breakers is 10,000 amps, often shown as 10 kA. However, circuit breakers with higher interrupting ratings are also available.

### **Main Circuit Breaker**

It is important to note the difference between a **main circuit breaker** and **branch circuit breakers**. The main breaker for a load center shuts off power to the entire load center and all circuits supplied by that load center. The main circuit breaker ratings determine the overall ratings of the load center.

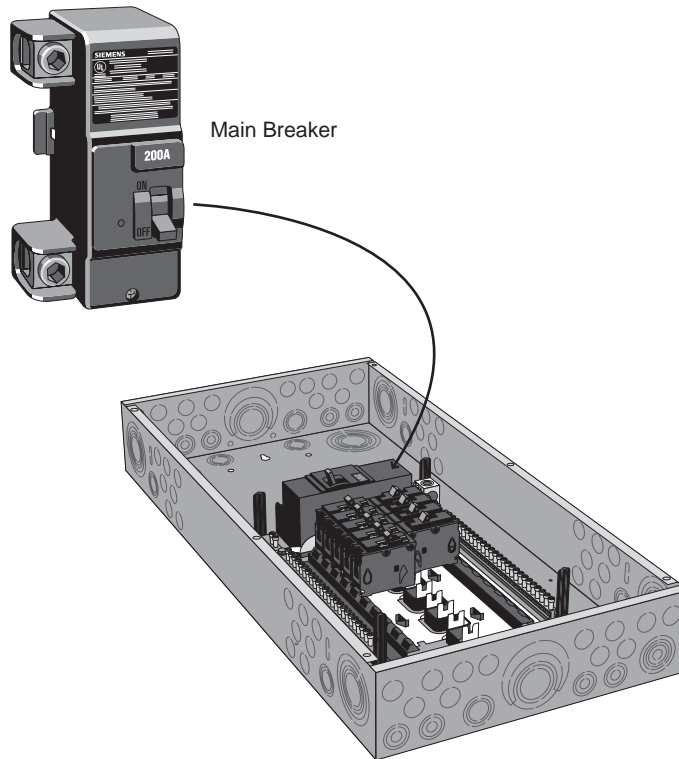

Siemens offers a wide selection of load centers equipped with a **main circuit breaker** as well as **main lug** load centers. Siemens PL series load centers are convertible from main lug to main breaker or vice versa.

### Branch Circuit Breakers

Load centers have multiple branch circuit breakers. Each branch circuit breaker provides circuit protection and manual control for one of the load center's branch circuits.

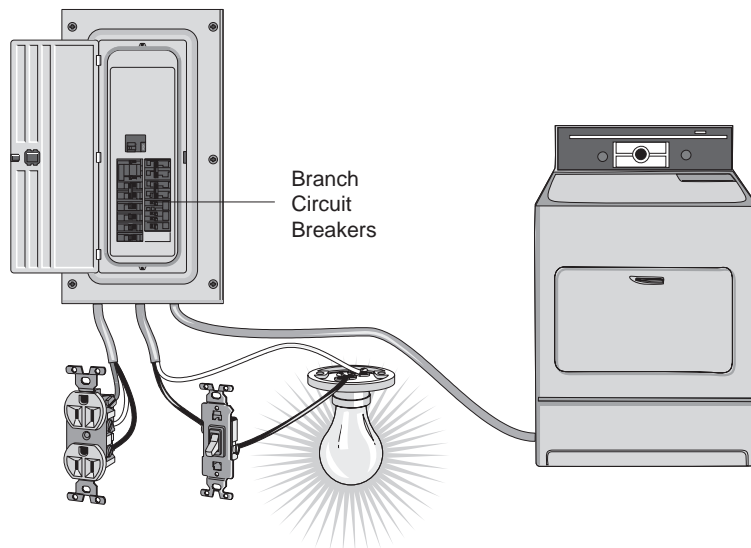

The most common branch circuit breakers used in Siemens load centers are full-sized 1-pole and 2-pole circuit breakers; however, Siemens also manufactures a variety of other circuit breaker types for use in load center branch circuits.

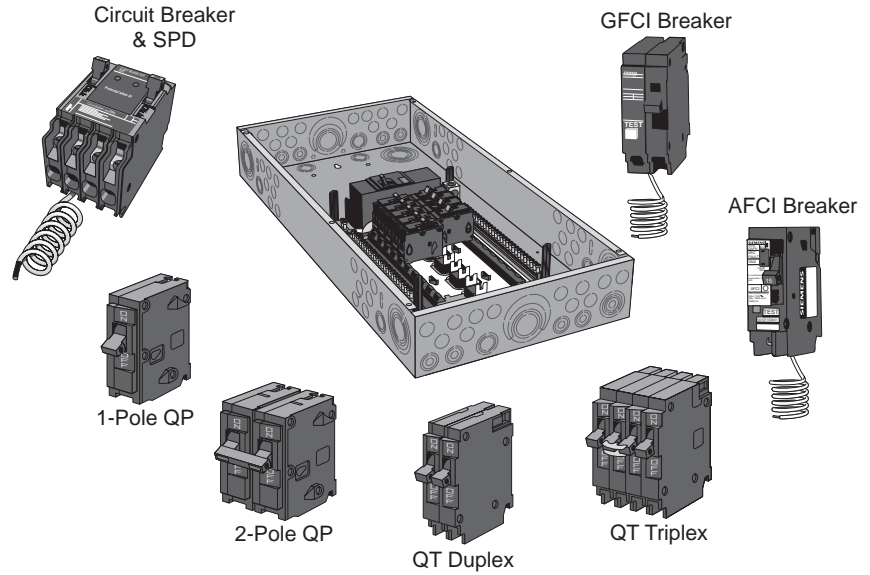

**QP Circuit Breakers**

**Type QP circuit breakers** are full-size breakers available as 1-pole, 2-pole, or 3-pole breakers. Full size means that each circuit breaker has a width of 1 inch per pole.

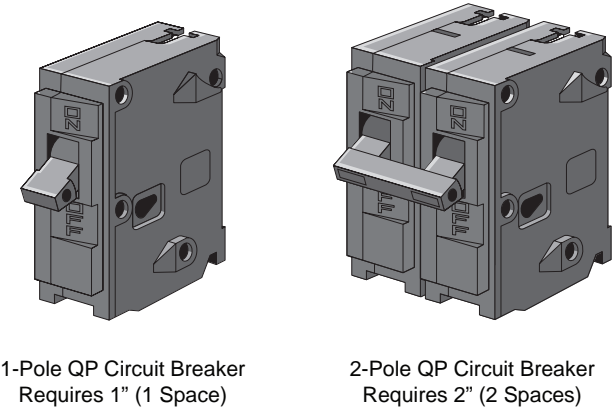

1-pole QP breakers are rated for 120 VAC and have continuous current ratings from 10 to 70 amps. 2-pole QP breakers are available with a 120/240 VAC rating or a 240 VAC rating. 2-pole 120/240 VAC QP breakers have continuous current ratings from 10 to 125 amps and 2-pole 240 VAC QP breakers have continuous current ratings from 15 to 100 amps. 3-pole QP breakers are rated for 240 VAC and have continuous current ratings from 10 to 100 amps.

All type QP circuit breakers have a 10 kA interrupting rating; however, Siemens also offers type QPH circuit breakers with a 22 kA interrupting rating and type HQP circuit breakers with a 65 kA interrupting rating.

**QT Circuit Breakers**

Some Siemens load centers are designed to accept **type QT Duplex, Triplex, and Quadplex plug-in circuit breakers**. These breakers are space saving breakers that are half the width per pole of type QP circuit breakers. This reduced width allows more circuits to be serviced from a load center, provided that the main circuit breaker has sufficient capacity. An important use for QT breakers is in cases where additional circuits are being added to an existing load center, but the number of spaces available in the load center is limited.

**Type QT Duplex Circuit Breakers**

Type QT Duplex circuit breakers combine two, independent, half-inch width breaker poles in a common unit. This unit plugs into one load center stab and requires one panel space.

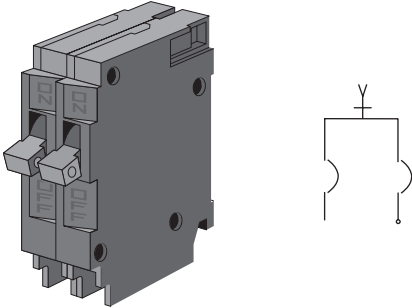

QT Duplex  
Two Independent 1-Pole Breakers  
Requires One Space

## QT Triplex and Quadplex Circuit Breakers

Type QT circuit breakers are also available in triplex and quadplex configurations. Triplex circuit breakers provide a 2-pole circuit breaker for 120/240 VAC circuits and two independent 1-pole circuit breakers for 120 VAC circuits. Quadplex circuit breakers incorporate two common trip 2-pole circuit breakers for 120/240 VAC circuits. Each Quadplex or Triplex circuit breaker requires two panel spaces.

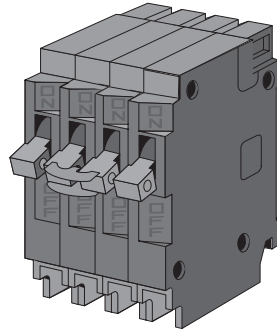

QT Triplex  
Two Independent 1-Pole Breakers  
One Common Trip 2-Pole Breaker  
Requires Two Spaces

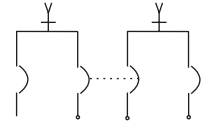

QT Quadplex  
Two Sets of Common Trip 2-Pole Breakers  
Requires Two Spaces

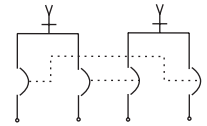

## Review 3

1. Current flow in a conductor always generates \_\_\_\_\_.
2. A circuit breaker's \_\_\_\_\_ number indicates the number of circuits which supply current through the circuit breaker.
3. A \_\_\_\_\_ circuit breaker shuts off power to the entire load center and all circuits supplied by that load center.
4. A QT \_\_\_\_\_ circuit breakers combine two, independent, half-inch width breaker poles in a common unit.
5. QT Triplex and Quadplex circuit breakers each require \_\_\_\_\_ panel spaces.

# Ground Fault Protection

A ground fault occurs when a current-carrying conductor comes in contact with ground. A faulty appliance or the presence of water in contact with a conductor are examples of possible ways a ground fault can occur.

One way ground fault protection is accomplished is by the use of **ground fault circuit interrupter (GFCI)** receptacles. These are installed in place of a normal receptacle. Another way is with a GFCI circuit breaker such as a Siemens type QPF or QPHF GFCI circuit breaker. Both breaker types are available in 1-pole and 2-pole versions. Type QPF circuit breakers have a 10 kA interrupting rating and type QPHF circuit breakers have a 22 kA interrupting rating. Any receptacle connected to the same circuit as the QPF or QPHF GFCI circuit breaker is ground fault protected.

A ground fault circuit interrupter compares current on the hot wire with current returning on the neutral wire. Under normal circumstances the current is equal.

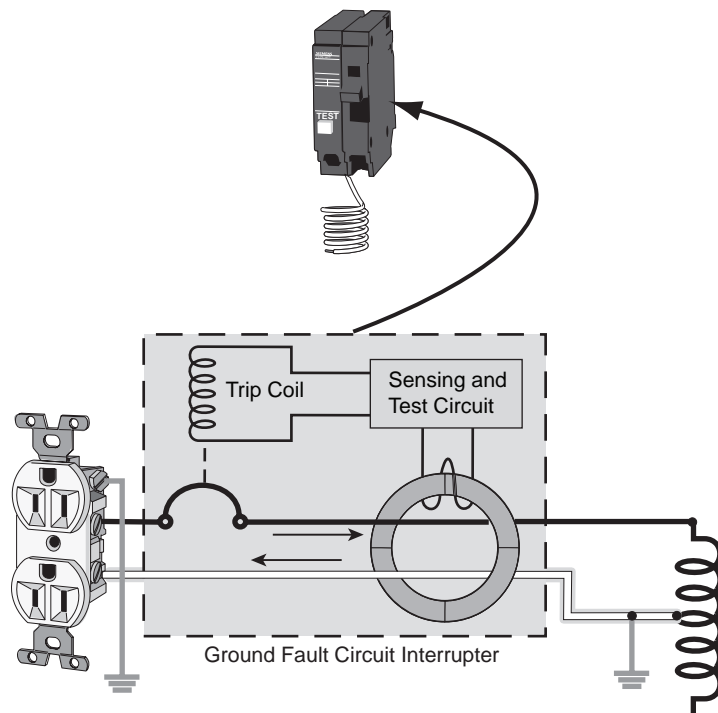

When a ground fault occurs, some of the current goes to ground through an alternate path. For example, a ground fault can occur when an electrical appliance is placed on a wet surface that provides an alternate path to ground. Anyone coming in contact with the appliance or the wet surface is at risk from this ground fault. If the circuit providing power to the appliance is protected by a ground fault circuit interrupter; however, the GFCI will sense the ground fault, open the circuit, and remove power from the appliance.

### **Ground Fault Protection for Personnel**

*NEC*® Article 210.8 describes the requirements for ground fault circuit interrupter protection for personnel in a variety of locations. Some of the more common locations requiring this protection for electrical receptacle circuits include: bathrooms; residential garages; unfinished basements; within six feet of a laundry, utility, or wet bar sink; crawl spaces; and outdoors.

Siemens QPF and QPHF GFCI circuit breakers, are intended to provide protection for personnel and are designed to trip when a fault current to ground of 6 mA or more is sensed.

### **Ground Fault Protection for Equipment**

Ground fault circuit interrupter protection is also sometimes needed to protect equipment from damaging line-to-ground faults. Siemens QE and QEH circuit breakers provide this protection by de-energizing the circuit when a ground fault of 30 mA or more is sensed. Type QE circuit breakers have a 10 kA interrupting rating and type QEH circuit breakers have a 22 KA interrupting rating. Both breaker types are available in 1-pole and 2-pole versions.

### **Installing GFCI Breakers**

Siemens GFCI circuit breakers mount in a load center in the same way as a standard circuit breaker except that they have one additional wire, a white “pigtail” neutral lead which connects to the load center’s neutral bus. These breakers are also equipped with a “Test” button to check the operation of the device after it has been installed.

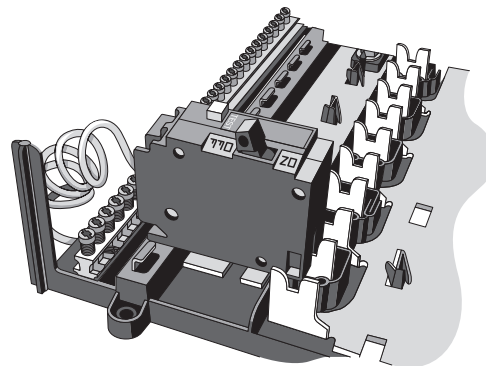



# Arc Fault Protection

## Arc Faults

**Arc faults** are undesired arcs in which current flows in unintended ways, but, in residential applications, usually not in sufficient amounts to cause a standard circuit breaker to trip.

Arc faults may occur for many reasons such as worn electrical insulation or damaged wiring, misapplied or damaged appliance cords and equipment, or loose electrical connections. In the following example, a staple has been inadvertently driven through the insulation of a wire during installation. This could potentially cause arc faults to occur.

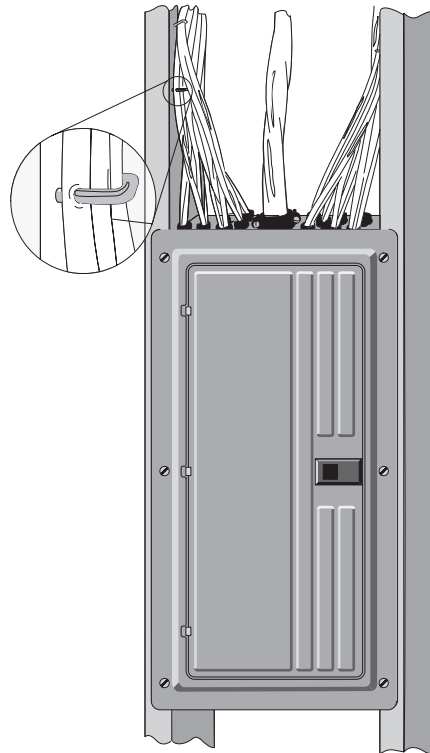

The arc fault problem is important because each year tens of thousands of fires are caused by electrical problems, and arc faults are one of the leading causes for these types of fires. Because the causes of arc faults are many and often difficult to eliminate, detecting arc faults and shutting down affected circuits before property damage, personal injury, or loss of life occurs is even more critical.

## AFCI Circuit Breakers

An **arc fault circuit interrupter (AFCI) circuit breaker**, in addition to providing overcurrent protection, is intended to provide a degree of protection from the effects of arc faults by recognizing the characteristics unique to arcing and de-energizing the circuit when an arc fault is detected.

There are two categories of AFCI circuit breakers. The first AFCI circuit breakers developed were **branch/feeder AFCI circuit breakers** that, in addition to providing overcurrent protection, are intended to protect branch and feeder wiring from the damaging effects of **line-to-ground arcs** and **high energy parallel arcs**. High energy parallel arcs are line-to-neutral arcs greater than or equal to 75 A.

More recently, **combination AFCI (CAFCI) circuit breakers** have been developed. CAFCI circuit breakers, in addition to providing overcurrent protection, are intended to protect downstream wiring from three categories of arc faults: line-to-ground arcs, high energy parallel arcs, and series arcs greater than or equal to 5 A. **Series arcs** are arcs on a single conductor.

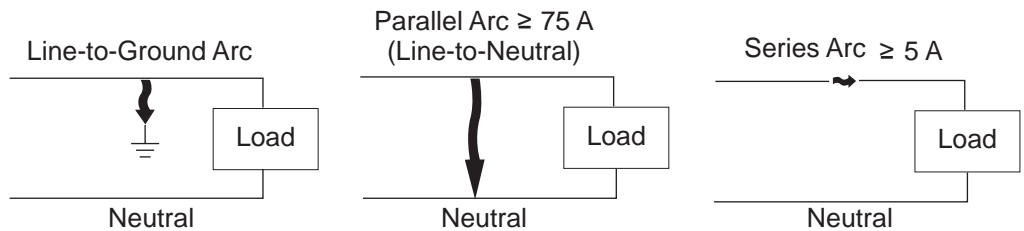

## NEC® Article 210.12

Requirements for arc fault circuit interrupter protection are covered in *NEC*® Article 210.12. Over the years, the wording of this article has evolved. Refer to the appropriate version of the code for your location to determine requirements for AFCIs and CAFCIs.

Siemens type QAF AFCI circuit breakers have a 10 kA interrupting rating and type QAFH AFCI circuit breakers have a 22 kA interrupting rating. Both breaker types are available in 1-pole and 2-pole versions.

Siemens AFCI circuit breakers have a white **pigtail** wire that attaches to the neutral bus. 2-pole CAFCI circuit breakers have two **Test** buttons and all other Siemens AFCI circuit breakers have one Test button. Test buttons are used to check the device operation after it has been installed.

As shown below, Siemens CAFCI circuit breakers are equipped with **LED trip indicators** which help electricians and home owners identify the cause of a tripped breaker.

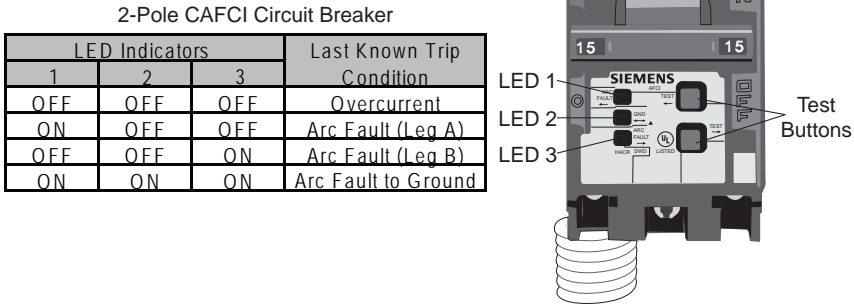
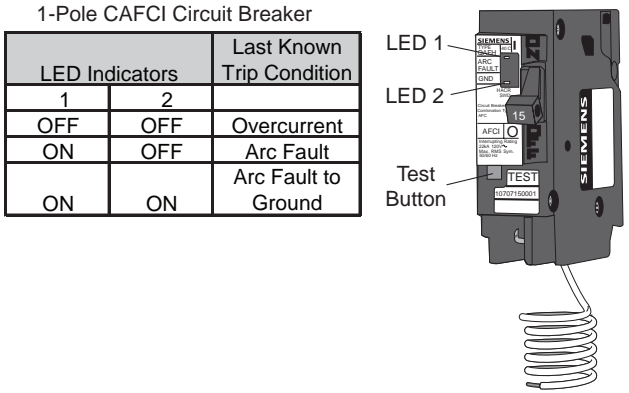

Siemens 2-pole CAFCI is intended for a different use than most 2-pole circuit breakers. Instead of being used with one 240 VAC circuit, it is intended for use on two, 1-pole, 120 VAC circuits. The 2-pole CAFCI is designed to allow contractors to use multi-wire branch circuits (commonly known as shared neutrals) which helps save on installation costs. When using single pole CAFCI's, a dedicated neutral is required for each circuit, but Siemens 2-pole CAFCI allows electricians to share neutrals between the two circuits fed by the breaker.

## Intelli-Arc Diagnostic Tool

Although the LEDs on Siemens CAFCLs can point an electrician in the right direction for troubleshooting, these AFCIs do not identify the portion of the branch circuit that contains a fault. Arc faults are often intermittent, which can make troubleshooting the branch circuit difficult. In these cases, it is important to determine whether the fault condition exists in the permanent wiring, in connected equipment, or in a power cord.

Siemens **Intelli-Arc Diagnostic Tool** helps to accurately diagnose the circuit in which a fault has occurred. This diagnostic tool can be used with any circuit breaker regardless of brand. When used in conjunction with good troubleshooting techniques, this tool allows the electrician to locate the cause of the fault more quickly, saving money for each branch circuit that must be evaluated.

The Intelli-Arc Diagnostic Tool presents information as to the type and magnitude of fault. Because the fault may not cause an AFCI to trip for various reasons, i.e., duration too short or current level too low, the tool provides an indication showing how close an event is to causing an AFCI to trip.

As shown in the following illustration, the Intelli-Arc Diagnostic tool includes a **base unit**, which is temporarily wired into a branch circuit, and a **hand-held unit**, which wirelessly communicates with the base unit.

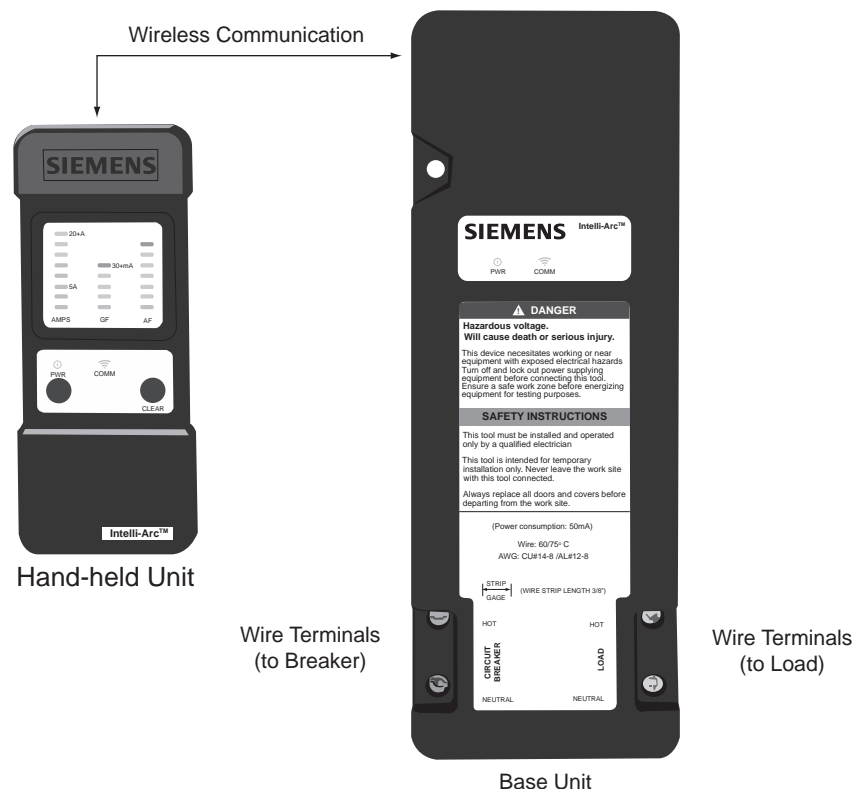

As the following illustration shows, the Intelli-Arc base unit can be easily wired into a branch circuit associated with an AFCI, GFCI, or conventional circuit breaker.

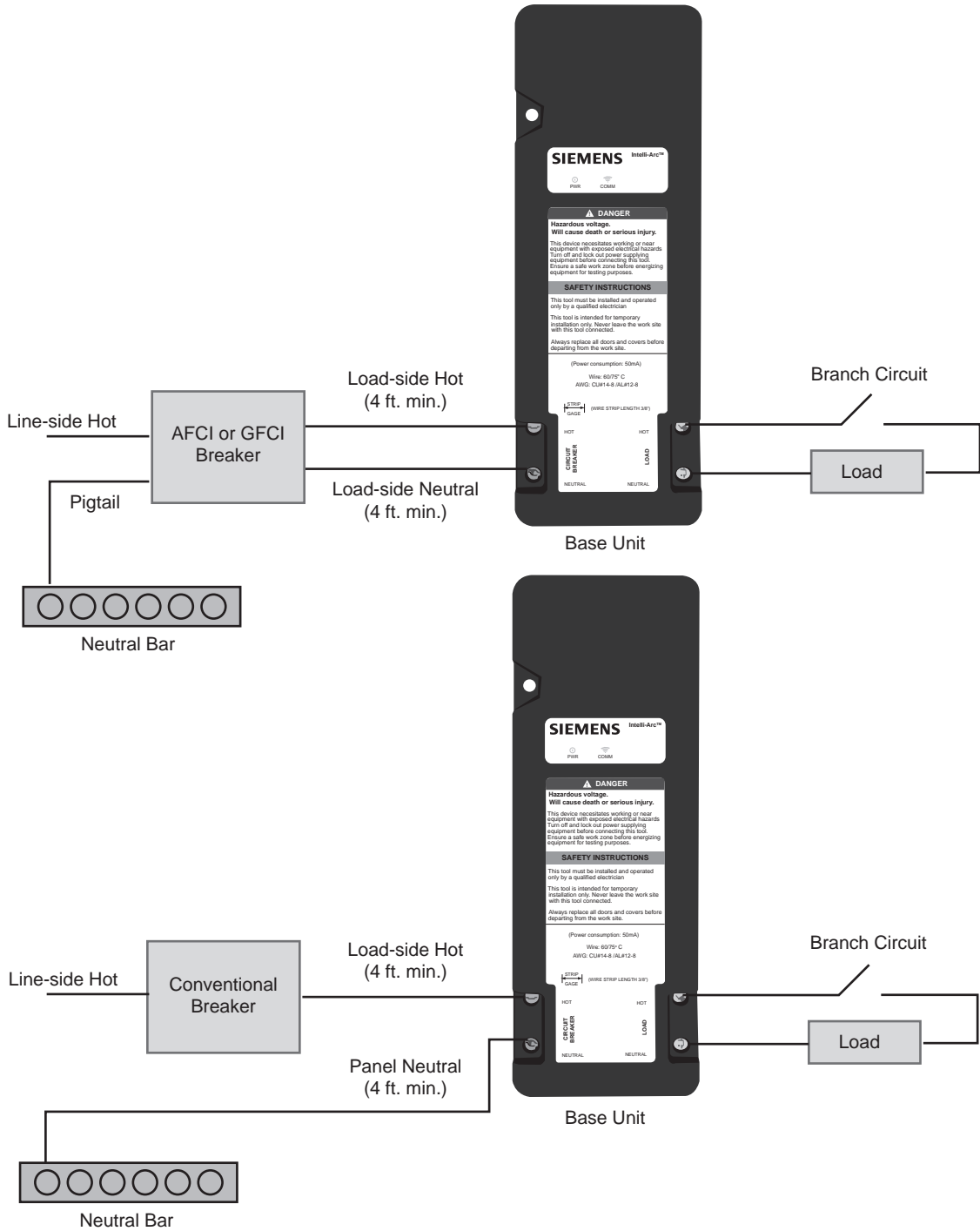

# Surge Protection

Today's homes have many electronic devices such as televisions, stereos, computers, microwave ovens, etc. These devices are highly susceptible to damage from electrical surges.

Electrical surges can be generated in the home by appliances such as vacuum cleaners and other motor driven devices; spark igniters on gas ranges, furnaces, and water heaters; and other equipment.

However, the most damaging surges are caused by lightning strikes. A lightning strike on a power line several miles away still has the potential to cause extensive electrical damage in a home. Lightning strikes on high voltage lines are generally dissipated by utility surge arresters. The average home, however, will experience eight to ten voltage surges of 1,000 to 10,000 volts annually. Damage to expensive electrical equipment can be instantaneous if the surge is significant, but even moderate surges over time can cause cumulative damage.



## Thunderstorms

A typical lightning strike consists of 25,000 amps at 30 million volts. The following map shows the approximate mean annual number of days with thunderstorms in various regions of the United States.

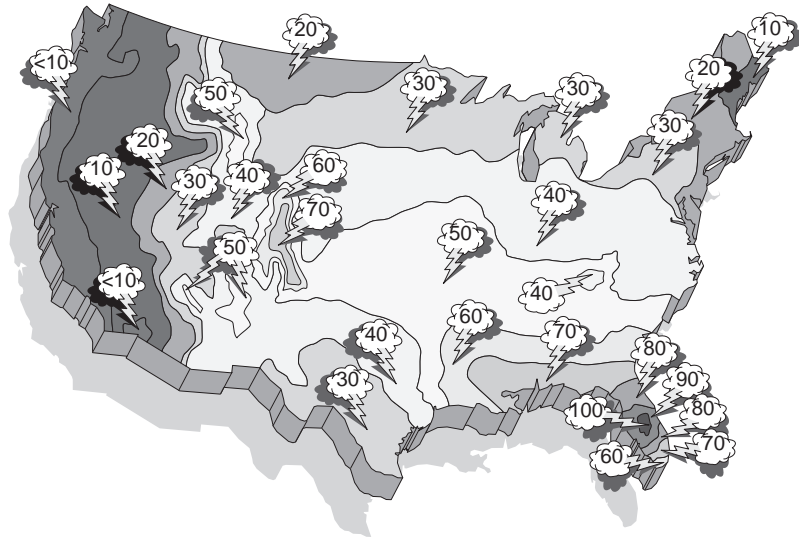

## Point of Entry Surge Protection

Siemens offers a variety of devices intended to minimize damage from electrical surges. One of these devices, **Siemens Circuit Breaker and SPD** (surge protection device), provides **point-of-entry surge protection** and also incorporates two 1-pole circuit breakers.

Siemens Circuit Breaker and SPD replaces two full-size, 1-pole, 15 amp or 20 amp circuit breakers and provides surge protection for all branch circuits.

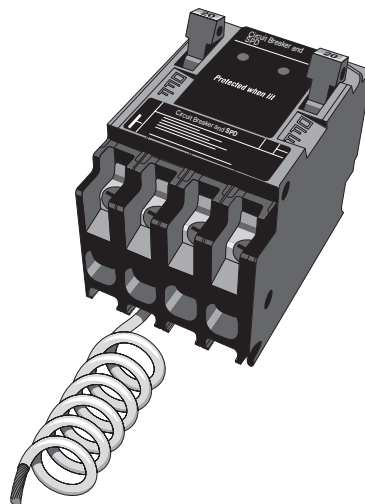

Circuit Breaker and SPD

The Circuit Breaker and SPD incorporates two red LED indicator lights that illuminate to show that surge protection is provided for all circuits connected to the load center. The Circuit Breaker and SPD notifies the owner of loss of surge protection by tripping one or both of the circuit breakers. The value of this feature is enhanced by using one of these breakers for circuit protection of frequently used household circuits so that the circuits controlled by the breaker also indicate the status of the surge protection.

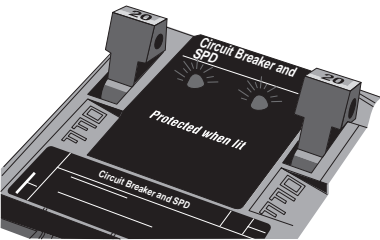

If one or both of the circuit breakers have tripped, turn both circuit breakers to the "OFF" then "ON" position. If either light is not illuminated, the device may still be used for circuit protection, but surge protection is no longer provided and the device should be replaced by a qualified electrician.

Installation is as simple as mounting a conventional circuit breaker in a Siemens load center. A lead wire is provided to connect the ground side of the module to the load center's neutral bus. It is recommended to position the device in the first position of the load center and connect the lead wire in the first neutral position.



## Review 4

1. The *NEC*® does **not** require GFCI personnel protection for electrical receptacles in which of the following areas?
  - a. bathroom
  - b. living room
  - c. outdoors
  - d. near sinks
2. \_\_\_\_\_ are undesired arcs in which current flows in unintended ways, but usually not in sufficient amounts to cause a standard circuit breaker to trip.
3. Siemens CAFCI circuit breakers are intended to protect downstream wiring from which of the following categories of arc faults?
  - a. line-to-ground arcs
  - b. high energy parallel arcs equal to or greater than 75 A
  - c. series arcs greater than or equal to 5 A
  - d. all the above
4. Siemens \_\_\_\_\_ helps to troubleshoot branch circuits for a potential arc fault condition.
5. Siemens \_\_\_\_\_ provide point-of-entry surge protection and also incorporates two 1-pole circuit breakers.

# Load Center Mains

## Main Breaker

There are two major categories of load centers, **main breaker load centers** and **main lug only load centers**. Some load centers, such as Siemens PL series load centers, are convertible from main breaker to main lug only or vice versa.

*NEC*® Article 408.36 requires that a panelboard have an overcurrent protection device with a rating that does not exceed the panelboard's rating. This overcurrent protection device can be located in the panelboard or on the supply side of the panelboard. There are exceptions to this rule, so refer to the article directly for additional information.

## Individual Protection

The following illustration shows these two approaches for applying overcurrent protection. If a main circuit breaker is located as an integral part of the load center, it is a main breaker load center. If a main circuit breaker is located remotely, then a main lug load center could be used. In this example the main breaker and load center are both rated for 200 amps.

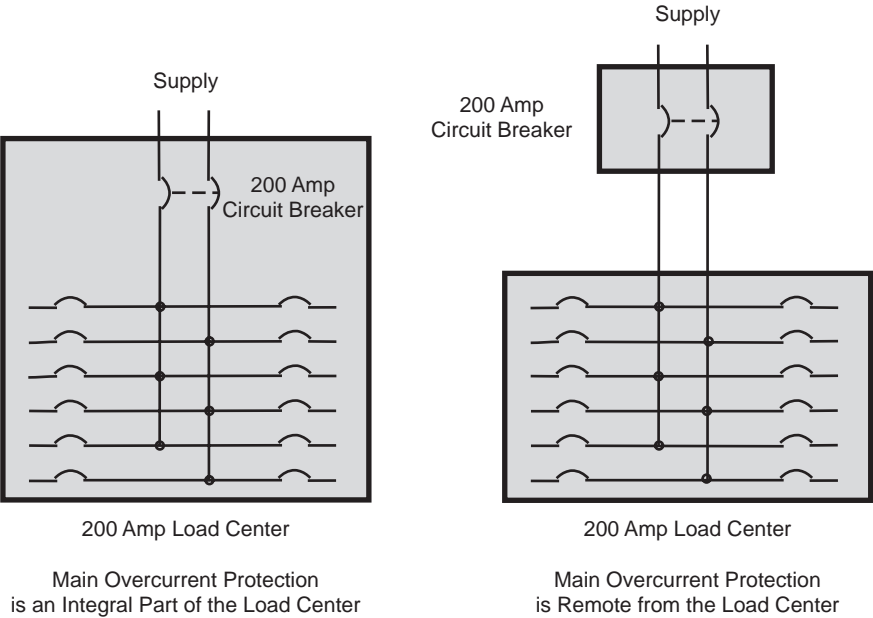

Main breaker load centers are often used in service entrance applications where the incoming supply cables connect to lugs adjacent to the main breaker which, in turn, feeds power to the load center and its branch circuits. The main breaker provides a means of manually disconnecting power from the load center and automatic overcurrent protection.

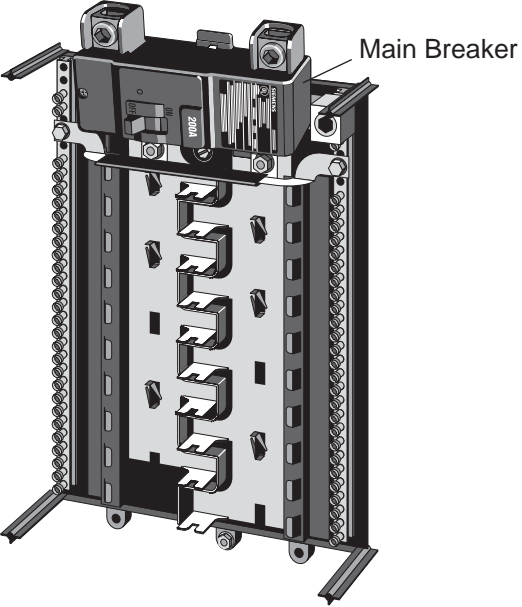

**Main Lug Only**

The following illustration shows the interior of a main lug only load center. As the name applies, main lug only type load centers do not have a main circuit breaker. The incoming supply cables are connected directly to the main lugs and bus bars.

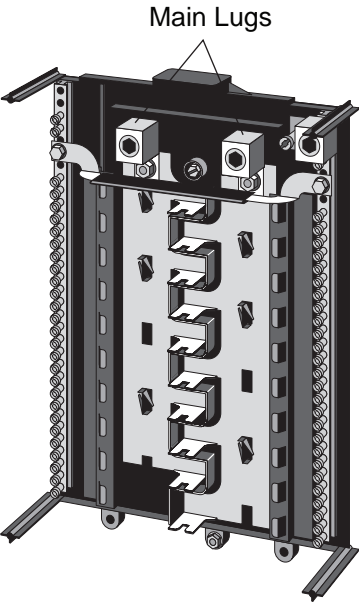

One common application for a main lug load center is as a subpanel. For example, a main breaker load center might supply power to a main lug load center located in an area of the home used as a workshop. Keep in mind, however, that the main breaker load center must be sized appropriately to handle the additional load.

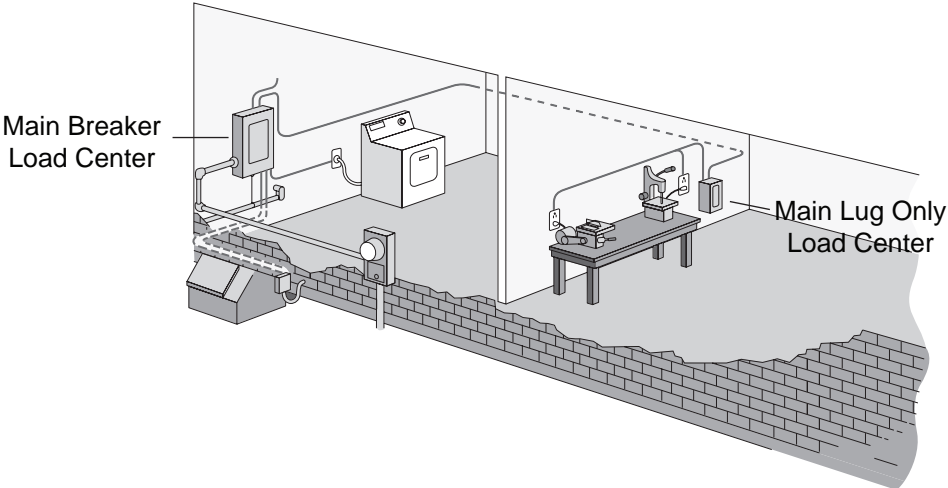

Main lug load centers are also used in other residential applications where the main breaker is located remote from the load center. For example, main lug load centers are often used in apartment installations where the main breakers and metering equipment are more centrally located.

# Load Center Interrupting Ratings

*NEC*® Article 110.9 requires circuit protection equipment to have an interrupting rating sufficient for the available current. There are two ways to achieve this requirement, the **full rating method** and the **series rating method**.

## Full Rating Method

The full rating method requires all circuit protection devices to have an interrupting rating equal to or greater than the available fault current. In single family homes, the available fault current normally does not exceed 10,000 amperes. This makes it inexpensive to use the full rating method.

In some residential applications, the available fault current may exceed 10,000 amperes. For example, in the case of a building with 22,000 amperes of fault current available at the service entrance, the full rating method, as shown in following example, requires every circuit breaker to have an interrupting rating of at least 22,000 amperes.

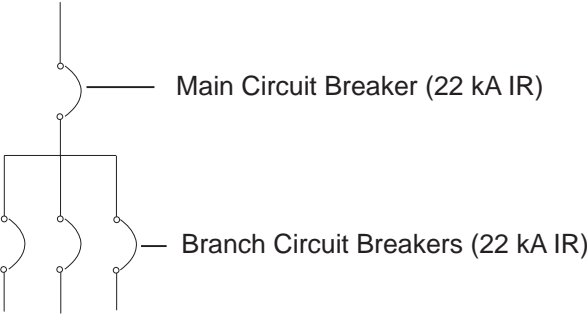

## Series Rating Method

The series rating method also requires the main circuit protection device to have an interrupting rating equal to or greater than the available fault current for the system, but subsequent downstream circuit protection devices connected in series can be rated at lower values.

For example, a building with 22,000 amperes of available fault current requires the main breaker at the service entrance to have at least a 22 kA interrupting rating, but downstream branch breakers can have a lower rating. In the following example, the downstream branch circuit breaker has a 10 kA interrupting rating.

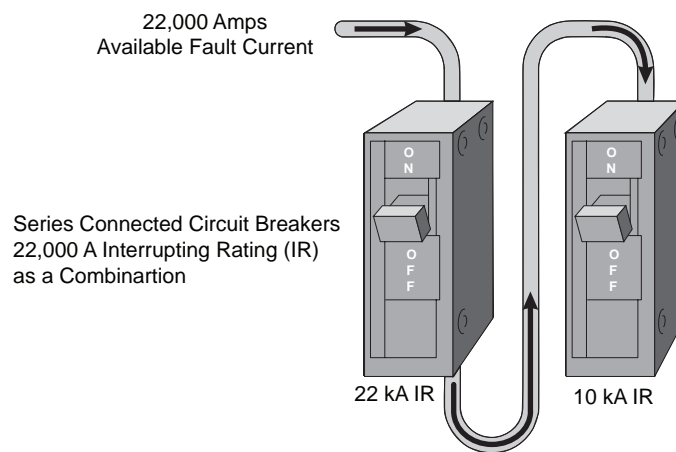

The series rating method is less expensive to the customer because it allows use of branch circuit breakers with a lower interrupting rating. However, series-rated circuit breaker combinations must be tested in series in order to be UL recognized. In addition, *NEC*<sup>®</sup> article 110.22 requires the series ratings to be marked on the enclosure.

In larger installations, such as apartments, condominiums and commercial facilities, the available fault current will normally be greater than 10,000 amperes. In these situations it is not uncommon to see three breaker series combinations.

The main power of an apartment complex, for example, might have 65,000 amperes available fault current. The main circuit breaker for a modular metering installation must be capable of interrupting this fault current. The tenant main breakers, however, may only have to be rated for 22,000 amperes of fault current, and branch breakers in each tenant load center may only have to be rated for 10,000 amperes of fault current.

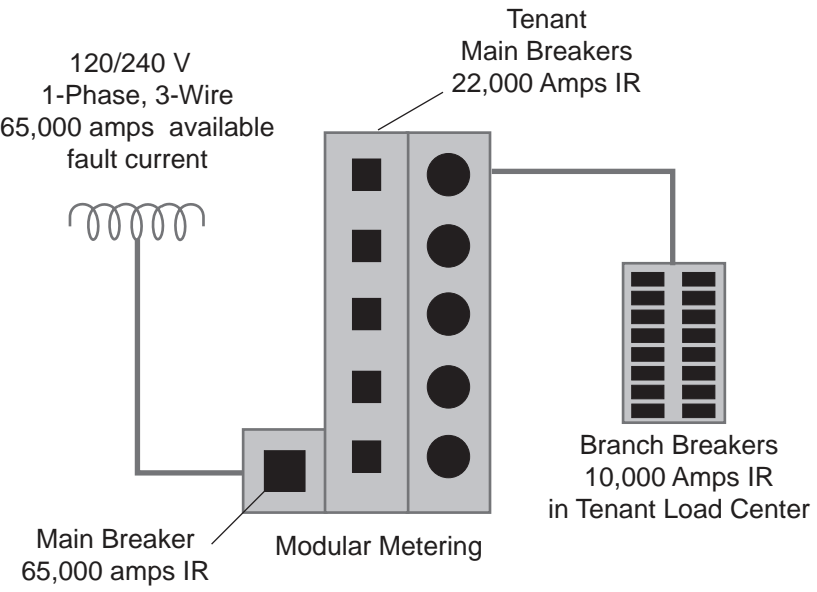

# Service Entrance Equipment Load Centers

Load centers are frequently used as service entrance equipment for a building. This is the equipment located near where the power supply enters the building. The incoming power supply is connected to this equipment which provides a means to control and cut off the supply.

Load centers used as service equipment must be listed and labeled as suitable for use as **service entrance equipment (SUSE)**.

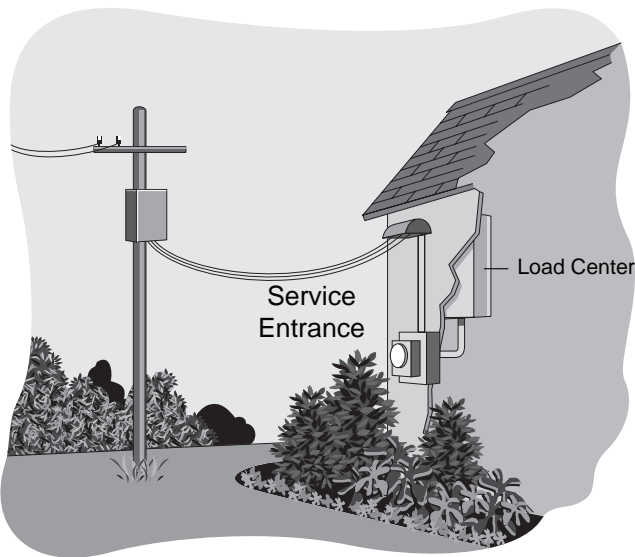

## Maximum Number of Disconnects for Service Entrance Equipment

Service-entrance conductors must have a readily accessible means of being disconnected from the power supply. NEC<sup>®</sup> Article 230.71 specifies that for each set of service entrance conductors no more than six switches or circuit breakers shall be used to disconnect and isolate the service from all other equipment.

Normally a main breaker load center is used as a service entrance panel and the main breaker provides the means of disconnecting and isolating the service.

Main lug only load centers are not normally used as service entrance equipment because to do so would limit the service entrance load center to no more than six circuit breakers.



# Power Supply Systems

## 1-Phase, 2-Wire System

Homes built prior to 1936, especially in rural areas, used a **two-wire supply system**. This system provided 120 volts between a hot conductor and a grounded conductor. A 2-wire system is usually inadequate for today's residential electrical demands and is not allowed for new construction.

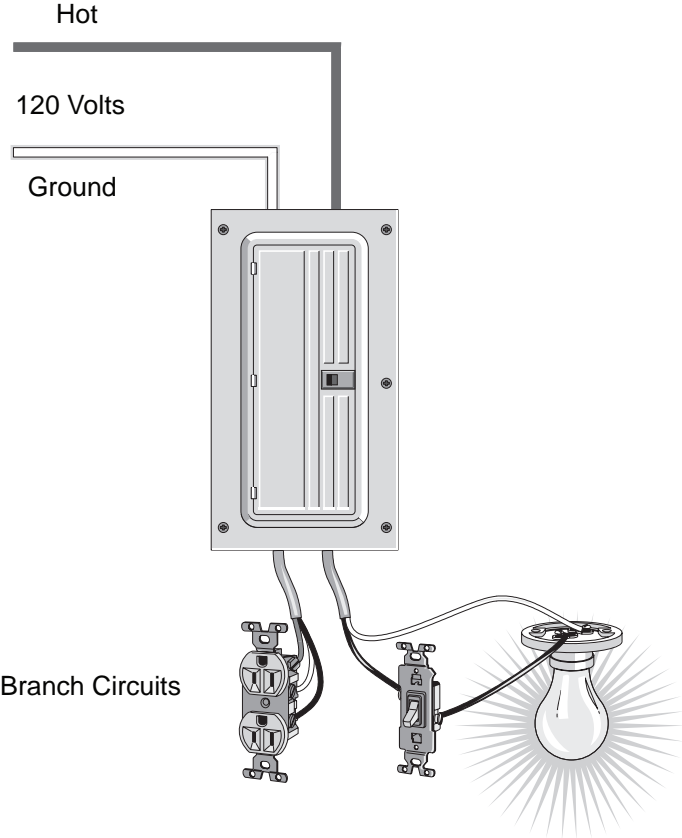

## 1-Phase, 3-Wire System

The most common supply system used in residential applications today is a **1-phase, 3-wire supply system**. This system provides 240 volts from the A phase connection to the B phase connection and 120 volts between either the A or B phase connection and neutral.

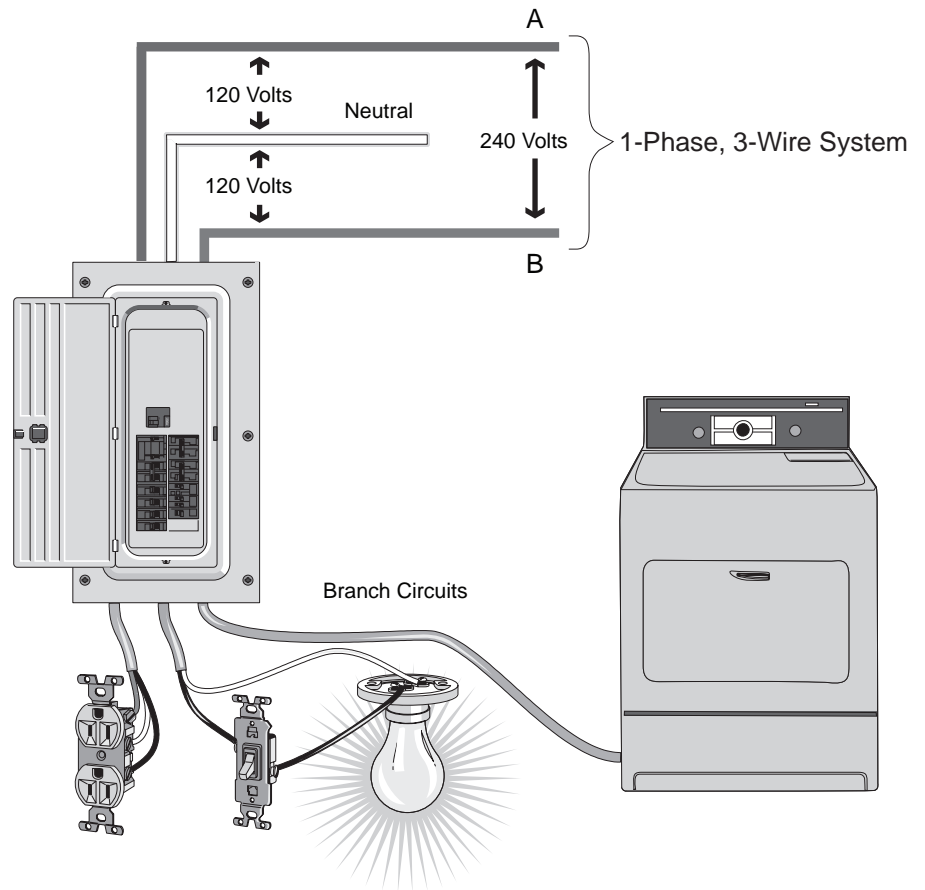

The following illustration shows how the **A and B phase connections** and the **neutral** connect to the secondary winding of the utility transformer.

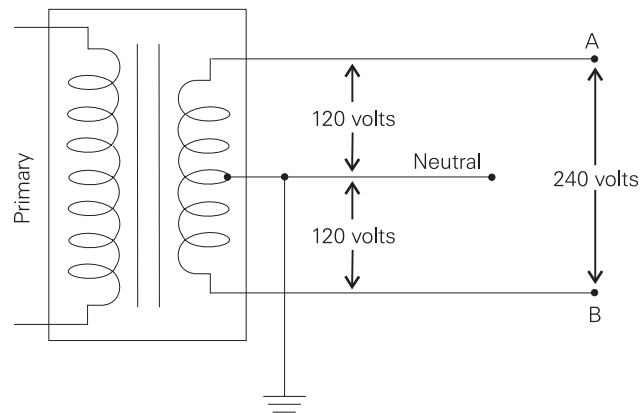

Load centers can also be used in commercial applications that may require **3-phase power**. Two of the more common approaches for providing 3-phase power in these applications are shown below.

**3-Phase, 3-Wire, 240 Volt**

The following illustration shows the utility transformer secondary windings for a **3-phase, 3-wire, 240 volt** system. This system uses a delta transformer configuration with each phase providing 240 volts.

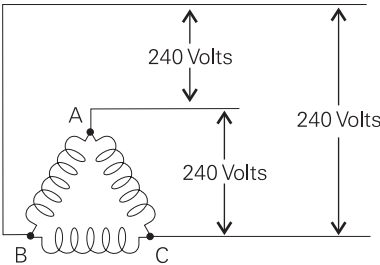

**3-Phase, 4-Wire, 208Y/120V**

There are multiple approaches for **3-phase, 4-wire** services. The following illustration shows the utility transformer secondary windings for one of the more common approaches, a 3-phase, 4-wire, 120/208 volt system. This system uses a wye transformer configuration with a grounded neutral (N). This system provides 120 volts between any phase connection and neutral and 208 volts between any two phases.

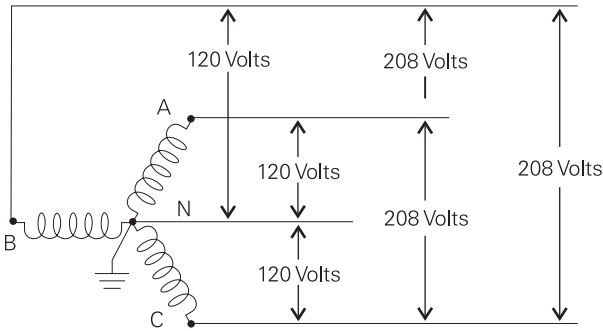

# Load Center Grounding

An object that is electrically connected to the earth is grounded, but not all ground connections are intentional. A ground connection can occur accidentally as a result of faulty equipment or wiring. Proper intentional grounding, however, is essential to the safe operation of electrical equipment.

## Service Entrance Grounding

When installing a load center, it is important to ground the neutral bus only at the service entrance, as shown in the following illustration. This is accomplished by connecting a grounding electrode to the ground bus or the neutral bus. The ground bus and neutral bus must be bonded to the enclosure at the service equipment so that both buses and the enclosure are connected to ground. In addition, the grounded neutral connection from the power source is also connected to the load center neutral bus.

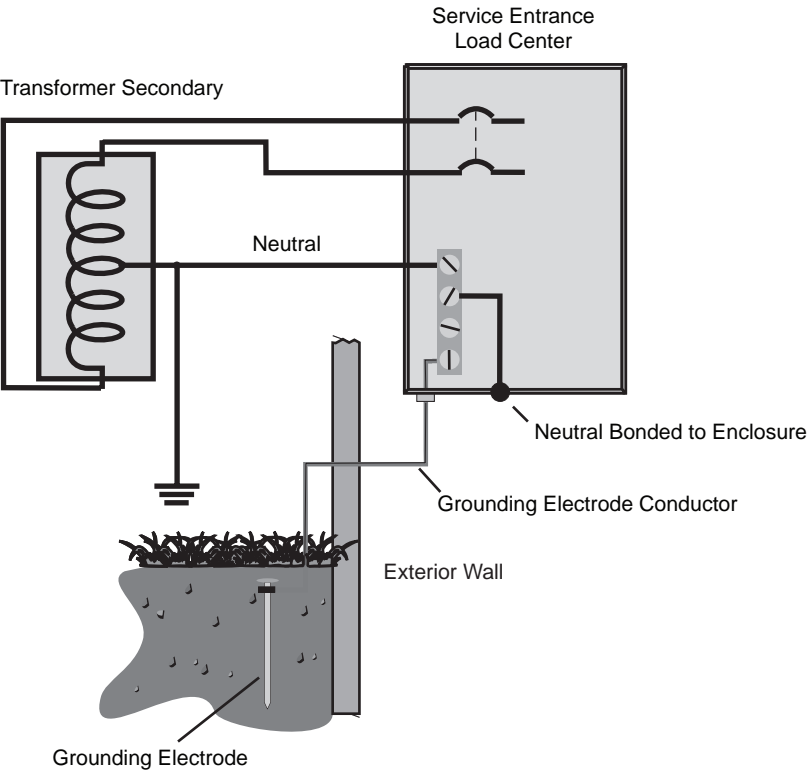

## Bonding

**Bonding** in this context is the joining of metallic parts to form an low resistance electrical connection. This is often accomplished through use of a bonding screw that connects a bus to a metal enclosure. Depending on the equipment design, a metal bonding strap may also be required. Siemens PL series and ES series load centers incorporate a pre-positioned bonding screw that eliminates bond strap/screw assemblies, eliminating the risk of losing components in the field.

## Grounding Downstream Load Centers

The neutral conductor is only directly connected to ground at the service entrance. When a downstream panel is used, the neutral is insulated and isolated in that panel. The downstream panel must have a ground connection bonded to the enclosure. The equipment ground conductor connects the downstream panel to the ground at the service entrance panel.

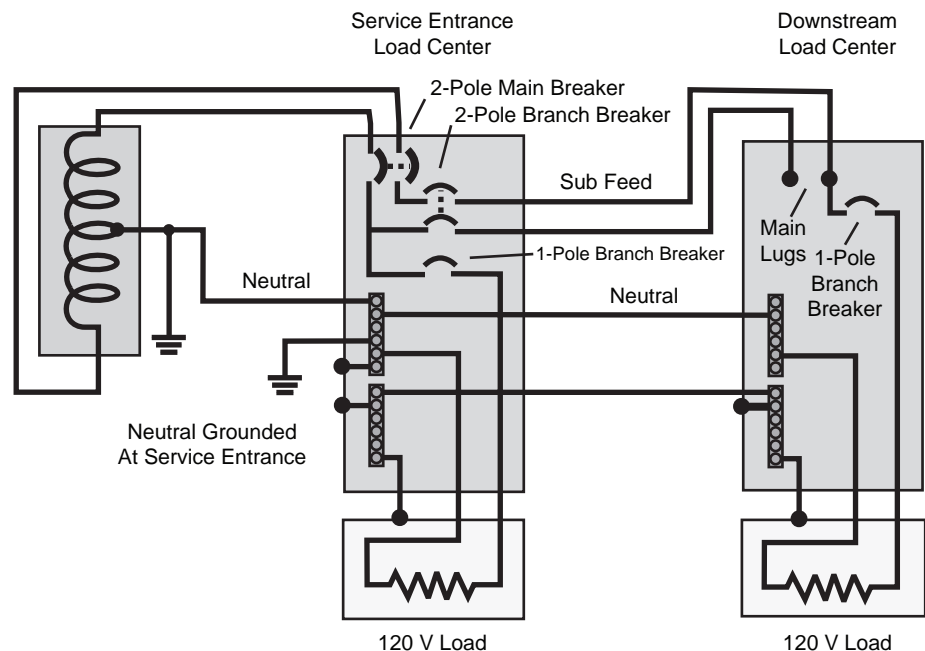

## Review 5

1. There are two major categories of load centers, those with a \_\_\_\_\_ and \_\_\_\_\_ load centers.
2. The \_\_\_\_\_ rating method requires selection of all circuit protection devices with individual ratings equal to or greater than the available fault current.
3. *NEC*<sup>®</sup> specifies that a maximum of \_\_\_\_\_ switches or circuit breakers shall be used to disconnect and isolate the service from other equipment.
4. When installing a load center, it is important to ground the neutral bus only at the \_\_\_\_\_.

# PL Series Load Centers

## Features

Siemens offers two primary load center product lines, **PL series** and **ES series**. **PL series load centers** offer the following features:

- Convertible from main breaker to main lug and vice versa.
- Invertible for bottom-feed applications
- Insta-wire neutrals and grounds
- Ground bus bars included
- Copper bus bars
- Dual neutrals on all configurations
- Carton-in-carton packaging with trims packaged separately.
- Lifetime warranty

## Product Offerings

The PL series load center product line provides a wide variation to meet any application need. The following items summarize the range of capabilities:

- 1-phase or 3-phase mains
- Main breaker or main lug
- 12 to 70 circuits/spaces
- Indoor and outdoor enclosures
- 100 to 225 amp current ratings
- Un-assembled offering for 3-phase

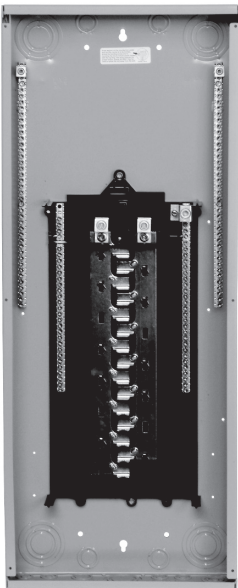

1-Phase PL  
Main Lug  
Load Center

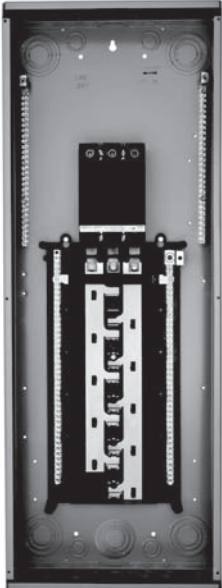

3-Phase PL  
Main Breaker  
Load Center

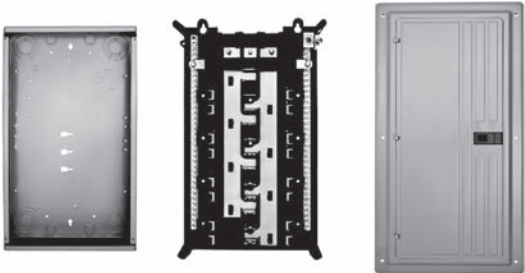

Un-assembled, 3-phase PL Load Center

## Installation Features

PL series load centers have been engineered for quick and easy installation. Examples of PL series installation features are shown below:

- Siemens patented Insta-wire screws on neutral and ground buses are captive to prevent loss of screws and backed out at the factory to speed wire installation.
- A bonding screw is pre-positioned and designed to avoid the need for bonding straps or separate screw assemblies.
- Two ground bars are factory-installed on all PL load centers.
- Slot/square combination screw heads on the neutrals, ground, trim, upper pan, and bond screws provide installation flexibility.
- The interior can be easily inverted for bottom-feed application.
- Load center mains can be converted from main breaker to main lug and vice versa.
- Mounting tabs on the trim hold it in place during installation to free up both hands when driving trim screws.
- The outdoor enclosure has a slide hinge for ease of installation.

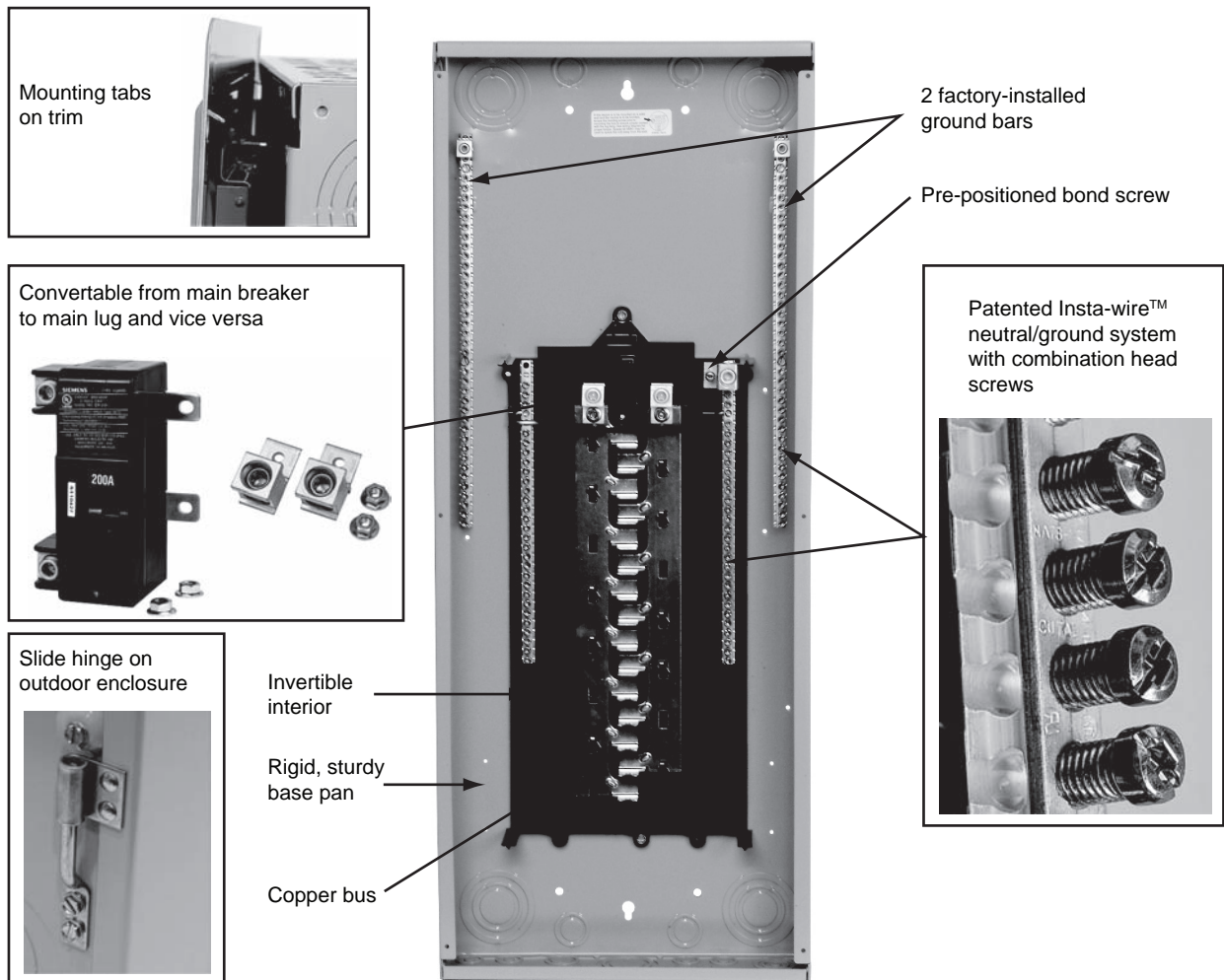

# ES Series Load Centers

## Features

**ES series load centers** offer the following features:

- Invertible for bottom-feed applications
- Insta-wire neutrals and grounds
- Aluminum bus bars
- Single-sided neutrals on load centers with 24 circuits or fewer
- Single-piece carton
- 10-year warranty

## Product Offerings

The ES series load center product line provides a wide array of variation to meet any application need. The following items summarize the range of capabilities:

- 1-phase or 3-phase mains
- Main breaker or main lug
- 12 to 70 circuits/spaces
- Indoor and outdoor enclosures
- 100 to 225 amp current ratings
- Value packs – a mix of branch breakers provided with the load center

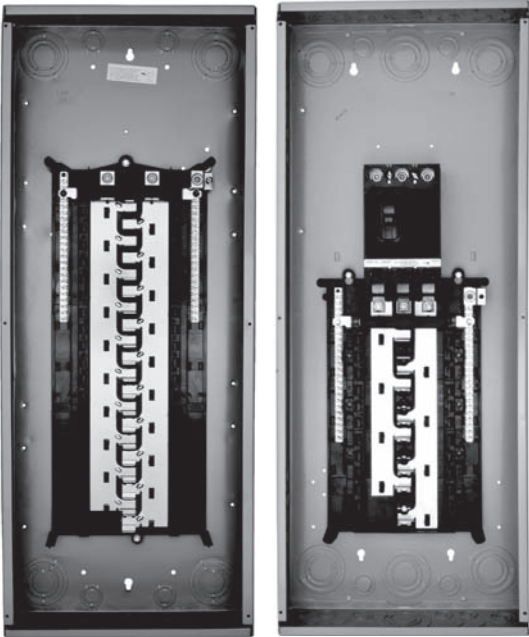

1-Phase ES  
Main Lug  
Load Center

3-Phase ES  
Main Breaker  
Load Center



## Installation Features

ES series load centers have been engineered for quick and easy installation. Examples of ES series installation features are shown below:

- Siemens patented Insta-wire screws on neutral/ground are captive to prevent loss of screws and backed out at the factory to speed wire installation.
- A bonding screw is pre-positioned and designed to avoid the need for bonding straps or separate screw assemblies.
- Slot/square combination screw heads on the neutrals, ground, trim, upper pan, and bond screws provide installation flexibility.
- The interior can be easily inverted for bottom-feed application.
- Main lug and main breaker load centers are available, but mains are not convertible
- Mounting tabs on the trim hold it in place during installation to free up both hands when driving trim screws
- The outdoor enclosure has a slide hinge for ease of installation.

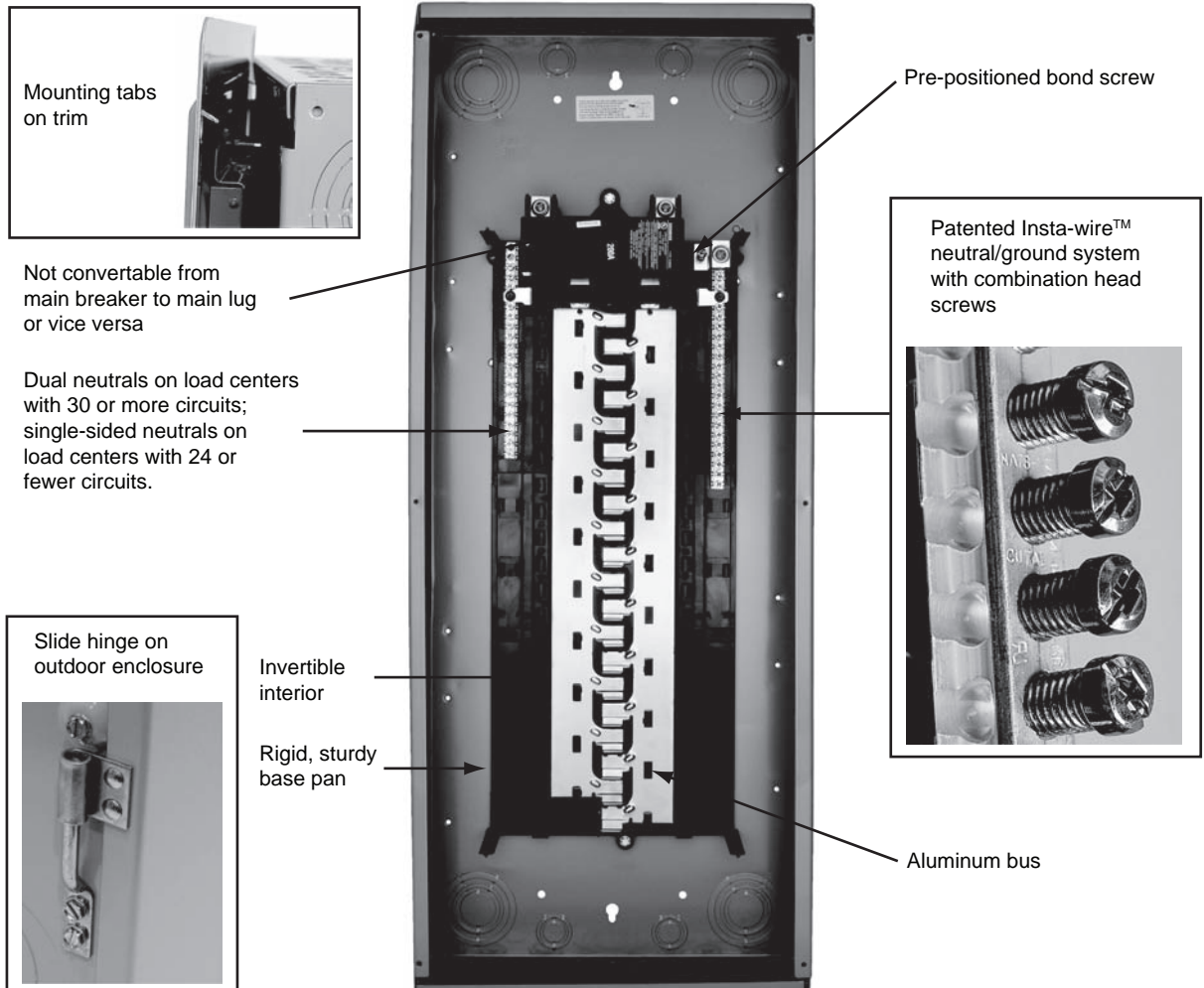

# Siemens EQ Load Centers

Siemens manufactures a variety of **EQ load centers** ranging from circuit breaker enclosures and small circuit load centers to 300-400 amp 1-phase and 3-phase load centers.

## **EQ 300-400 A Load Centers**

Siemens **EQ 300 to 400 amp main breaker and 400 amp main lug load centers** are available for 1-phase, 3-wire 120/240V and 3-phase, 3-wire and 4-wire 240V applications. Load center sizes range from 24 to 42 circuits. Both indoor (NEMA 1) and outdoor (NEMA 3R) enclosures are available.

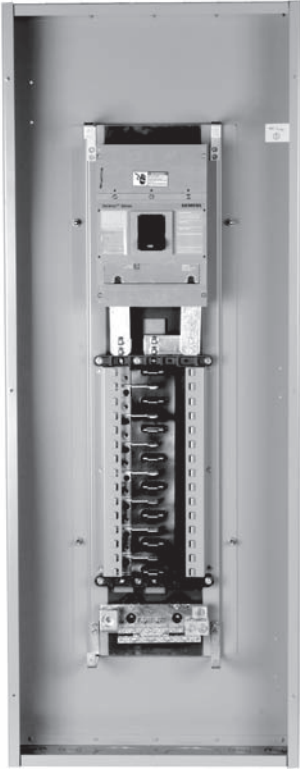

EQ 1-Phase, Main Breaker, 400 Amp Load Center

## EQ Small Circuit Load

Siemens **EQ small circuit load centers** are 1-phase, 3-wire, 120/240V load centers available with main lugs or main breaker and copper bus or main lugs and aluminum bus. Both indoor (NEMA 1) and outdoor (NEMA 3R) enclosures are available. EQ small circuit load center sizes range from 4 to 20 circuits, 100 to 200 amps. Among the products included are renovation panels and spa panels.

**Renovation panels** are ideal for older home projects where the distance between studs is narrower than the current construction practices. This narrower panel eliminates the need to notch out the existing studs.

**Spa panels** are intended for outdoor applications, such as hot tubs, that require ground fault protection. A factory-installed 2-pole GFCI breaker is provided along with two extra circuits.



Small Circuit  
Main Lug Load Center

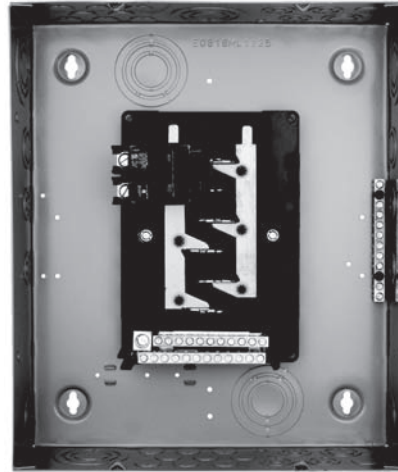

Renovation Panel

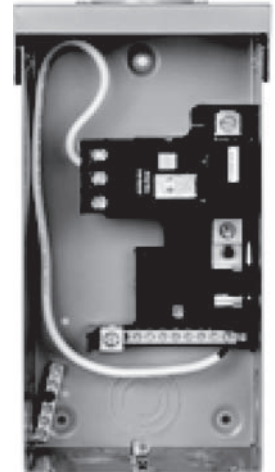

Spa Panel

## EQ Circuit Breaker Enclosures

**EQ circuit breaker enclosures** are designed for use with QP, QT, QPH, HQP, BQ, BQH, HBQ, QPP, QPPH, HQPP, QJ2, QJH2, and QJ2-H circuit breakers. Both indoor (NEMA 1) and outdoor (NEMA 3R) enclosures are available.

EQ circuit breaker enclosures for 1-phase, 3-wire, 120/240V applications are available with ampere ratings from 60 to 225 amps. EQ circuit breaker enclosures for 3-phase, 3-wire 240V and 3-phase, 4-wire, 120/208V, 120/240V, and 240V applications are available with 100 or 225 amp ratings.



EQ 200A Outdoor Enclosure  
with Circuit Breaker



EQ 100A Outdoor Enclosure  
with Main Lugs

# Generator Ready Load Centers

Siemens **Generator Ready Load Center** is a 200 or 225 amp, 30-circuit, 42-space load center that provides an effective solution for implementing generator backup of critical circuits. Both main lug and main breaker versions are available with indoor (NEMA 1) or outdoor (NEMA 3R) enclosures. Main lug load centers are convertible to main breaker load centers and vice versa with the appropriate conversion kit.

These load centers are equipped with two interiors. Up to 30 critical circuits are wired to the lower interior. Non-critical circuits are wired to the upper interior. Both interiors are powered by the electrical utility during normal operation. When utility power is not available, the critical circuits connected to the lower interior can be switched to generator power.

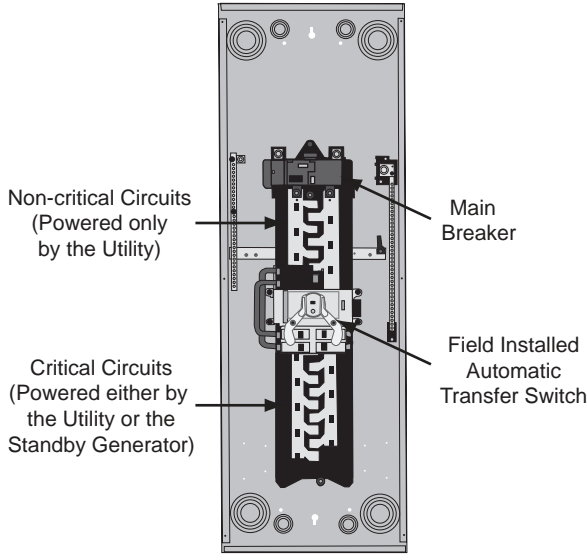

Main Breaker Load Center

In order to accomplish this, an automatic transfer switch or a manual transfer switch must be installed. The switch, along with any branch circuit breakers required for the application, must be ordered separately. However, installing the load center without the transfer switch is a cost effective approach for new construction when a generator will not be initially installed. This approach allows the wiring needed for standby generator operation to be completed during initial construction. At a later time, the homeowner can install a standby generator without the cost of re-wiring.

# Riser Panel Load Centers

## Riser Panels

**Riser panels** are intended for use in high-rise applications. The interior in riser load centers is shifted to the left to allow extra room for riser cables to pass through. Siemens main lug riser panels are available with 125 or 200 amp ratings. Main breaker conversion kits are available. The panels may be mounted with main lugs on top or inverted to allow cables to pass on the opposite side.

The riser panels are 1-phase only, but can be fed from 1-phase or 3-phase systems running through the gutter. The riser gutter tap kit (ECRLK250) allows the installer to tap off the main conductors.

Where an existing Siemens 1-phase or 3-phase load center (24-inch or larger) is used in place of the riser panel load center, the riser gutter (RAG24) can be installed to convert the load center to a riser panel. Load center mounting hardware, a pass-through brush, and flush trim are included.

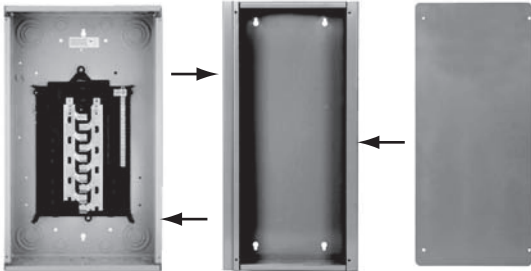

Any Load Center  
24" or Larger

Riser Gutter

Flush Trim



Riser Panel  
Load Center

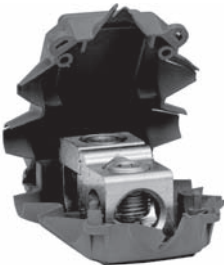

Riser Gutter  
Tap Kit  
(ECRLK250)

# Load Center Catalog Numbers

Siemens load centers have an eight-part catalog number system; however, parts seven and eight may be blank depending upon the load center configuration chosen.

The following example (P1224B1100SCU) is for a load center with the following characteristics:

- PL series indoor, type 1 enclosure
- Maximum of 12 spaces for 1-inch breakers
- Maximum of 24 circuits
- Main breaker
- 1-phase
- 100 ampere rating
- Surface mounting
- Copper bus bars

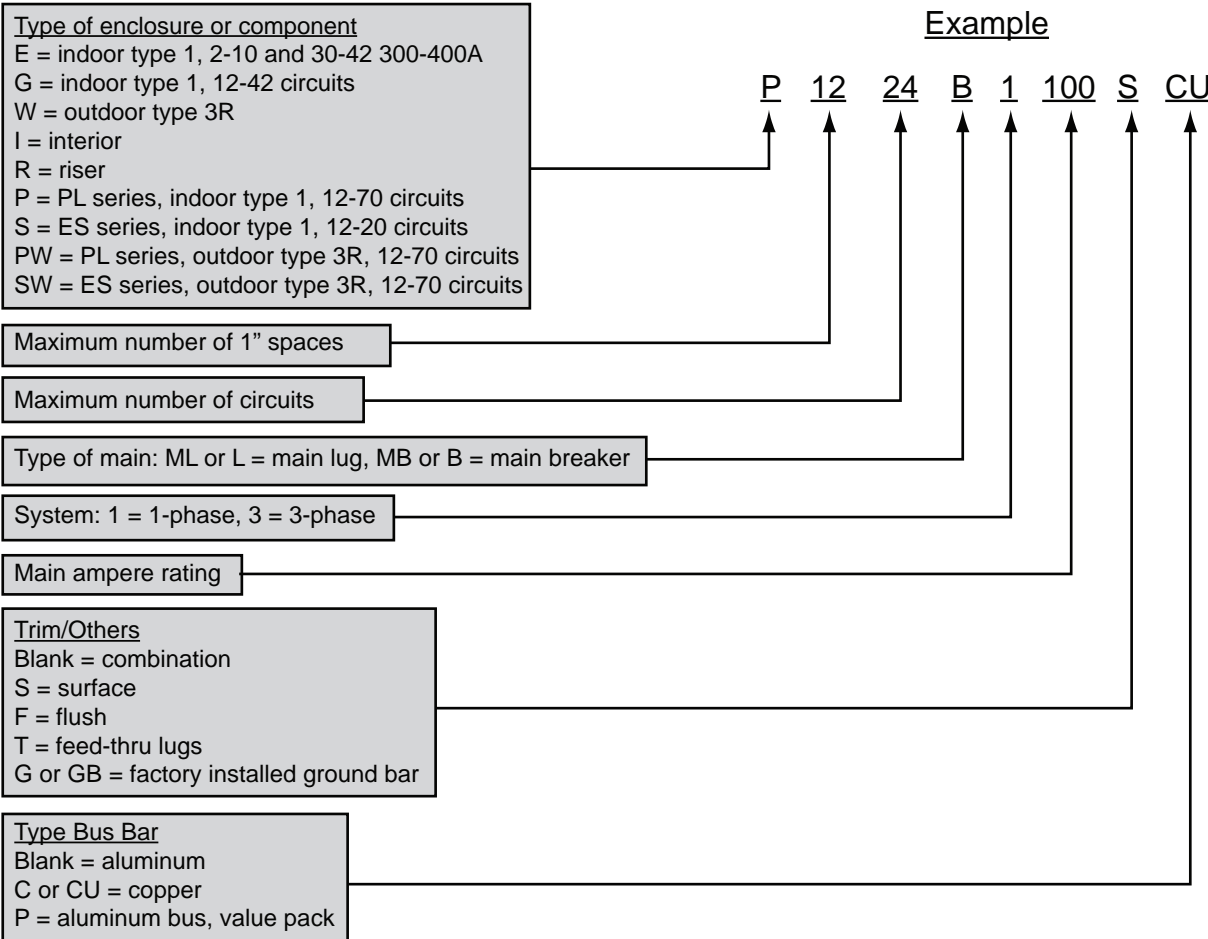

## Review 6

1. Siemens \_\_\_\_\_ load centers are convertible from main lug to main breaker and vice versa, have copper bus bars, have dual neutrals on all configurations, and carry a lifetime warranty.
2. Siemens \_\_\_\_\_ load centers have aluminum bus bars, single-sided neutrals on load centers with 24 or fewer circuits, and carry a 10-year warranty.
3. Siemens PL series and ES series load centers have Siemens patented \_\_\_\_\_ screws on neutral/ground systems.
4. Siemens manufactures a variety of \_\_\_\_\_ load centers ranging from circuit breaker enclosures and small circuit load centers to 300-400 amp 1-phase and 3-phase load centers.
5. Siemens \_\_\_\_\_ load center is a 200 or 225 amp, 30 circuit, 42 space load center that provides an effective solution for implementing generator backup of critical circuits.
6. Siemens \_\_\_\_\_ panels have an interior that is shifted to the left to allow extra room for cables to pass through.



# Sizing The Load Center

Planning is an important first step for all electrical projects. Careful engineering is required so that the distribution system safely and efficiently supplies adequate electric service to both present and possible future loads. As part of this planning, procedures in the *NEC*<sup>®</sup> should be used to correctly size the load center based upon the following characteristics:

- General lighting based on square footage of living space
- Small appliance load
- Laundry circuit
- Large appliance load
- Miscellaneous appliance load

## Power Calculations

When a force causes motion, work is accomplished. In an electrical circuit, voltage applied to a circuit causes electrons to flow. Voltage is the force and electron flow, measured in amps, is the motion.

The rate at which work is done is called power. The unit of measure for power depends on the type of power. For example, apparent power is the product of voltage (in volts) times current (in amps). Therefore, apparent power is expressed in volt-amps (VA). True power, on the other hand, is the product of apparent power times the power factor. True power is expressed in watts. For a more complete explanation of true power and apparent power refer to the STEP course titled **Basics of Electricity**.

Manufacturers of electrical equipment often rate their products in watts based on power measurements taken with rated voltage and current applied. For many applications, such as the single-family home described on the following pages, power is expressed in VA when rated current and voltage are known, but power factor is not known. The following example uses apparent power values, expressed in VA, to simplify the description and arrive at an approximate solution. More exact calculations are often needed to design circuits for real applications.

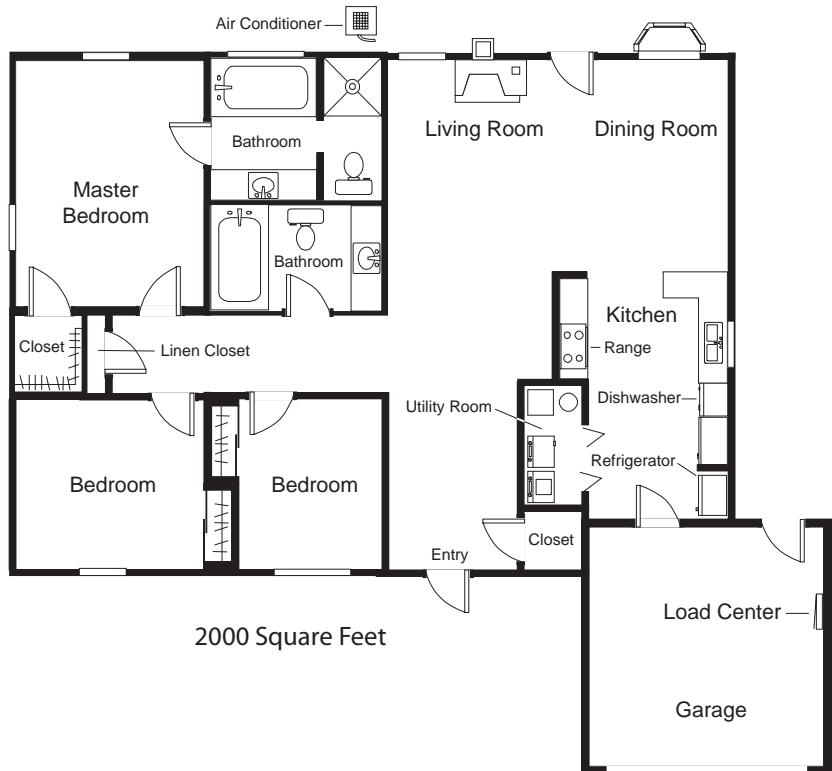

This sample floor plan is for a 2000 square foot home that has a 9600 VA (240 volts x 40 amps) air conditioner, a 9600 VA (240 volts x 40 amps) electric range, 12,000 VA (240 volts x 50 amps) of electric heating, a 5000 VA (240 volts x 20.8 amps) clothes dryer, a 1500 VA (120 volts x 12.5 amps) dishwasher, and a 1176 VA (120 volts x 9.8 amps) garbage disposal. Three small appliance circuits will be used in the kitchen area.

**Note:** A thorough knowledge of the *NEC*<sup>®</sup> is required to properly size load centers and conductors. If you will be performing this task, you are encouraged to become familiar with this code.

### General Lighting Load

According to *NEC*<sup>®</sup> Table 220.12, the minimum general lighting load for a dwelling is calculated at 3 VA per square foot of living space. This includes non-appliance receptacles for items such as table lights and television sets. The example has 2,000 square feet of living space. The calculated living space does not include carports, garages or unfinished spaces, such as basements, that are not adaptable for future use. The required general lighting load for this example is 6000 VA.

$$3 \text{ VA} \times 2000 \text{ square feet} = 6000 \text{ VA}$$

### Small Appliance Loads

According to *NEC*® Article 210.11(C)(1) at least two 120 volt, 20 amp small appliance circuits shall be provided. These are located in the kitchen area for small appliances such as toasters and coffee makers. *NEC*® Article 220.52(A) also states that these circuits shall be rated at 1500 VA. In this example house, there will be three small appliance circuits for a total rating of 4500 VA.

$$3 \times 1500 \text{ VA} = 4500 \text{ VA}$$

### Laundry Circuit

*NEC*® Article 210.11(C)(2) requires at least one 120 volt, 20 amp circuit for the laundry area. Article 220.52(B) states that this circuit shall not be less than 1500 VA.

$$1500 \text{ VA}$$

### Total General Lighting and Small Appliance Load

From the previous calculations the total general lighting and small appliance load is:

General lighting	6000 VA
Small appliance load	4500 VA
Laundry circuit	1500 VA

**Total** **12,000 VA**

### Demand Factors

All residential electrical outlets are never used at one time. Because of this, the *NEC*® allows for a demand factor in sizing electric services. Demand factors for general lighting are given in *NEC*® Table 220.42. The first 3000 VA is rated at 100%. The remaining 9000 VA (12,000 VA minus 3000 VA) may be rated at a demand factor of 35%.

First 3000 VA at 100%	3000 VA
Remaining 9000 VA at 35%	3150 VA

**Net general lighting and small appliance load** **6150 VA**

### Large Appliance Loads

Large appliance loads must be considered individually. The following large appliances are used in the example:

Air conditioner	9600 VA
Electric clothes dryer	5000 VA
Electric heat	12,000 VA
Electric range	9600 VA

Air conditioner and electric heat will not be used at the same time. Only the larger of the heater load or air conditioner load is used (*NEC*<sup>®</sup> Article 220.82(C)). In this case, the heater load (12,000 VA) is greater than the air conditioner load (9600 VA).

All other large appliance loads must be calculated at 100% except for the electric range. *NEC*<sup>®</sup> Table 220.55 allows a demand factor for electric ranges. Not all burners will normally be on high at the same time. According to Table 220.55, an electric range with a rating not greater than 12,000 watts can have a demand factor of 8000 watts. For the purpose of this calculation, assume that the power factor is 0.9, this results in an apparent power rating for the electric range of 8889 VA (8000 watts divided by 0.9).

Electric heat	12,000 VA
Electric clothes dryer	5000 VA
Electric range	8889 VA

**Net large appliance load 25,889 VA**

**Miscellaneous Loads**

Miscellaneous appliance loads must also be taken into consideration. The example has the following miscellaneous appliance loads:

Dishwasher	1500 VA
Garbage disposal	1176 VA

**Total miscellaneous appliance load 2676 VA**

**Required Service**

The required service size is found by adding the calculated values together.

General lighting, laundry and small appliance load	6150 VA
Net large appliance load	25,889 VA
Miscellaneous appliance load	2676 VA
<b>Total load</b>	<b>34,715 VA</b>

The average power supply for residential use is 120/240 volts. To determine the required load center rating divide the total load by 240 volts (the highest voltage used).

$$34,715 \text{ VA} \div 240 \text{ volts} = 144.6 \text{ amps}$$

A Siemens load center rated for 150 amps could be selected. Before a load center is selected, however, it is important to plan for electrical service expansion by providing space for at least two future branch circuits. Since the load for these future circuits is undetermined, add ten amperes per space. The amperage requirement is now 160.9 amps.

$$144.6 \text{ amps} + 20 \text{ amps (expansion)} = 164.6 \text{ amps}$$

**Safety Factor**

Circuit breakers are affected by the temperature of the air surrounding them. For this reason an additional safety factor of 20% is added to the load center requirements.

$164.6 \text{ amps} + (.20 \times 164.6) = 197.5 \text{ amps}$ . Therefore, a **200 amp load center** is a good choice.

**Determining the Number of Circuits**

Calculating the number of circuits required in a load center involves an understanding of how circuits are configured. In the following example, a 120/240 volt power supply is connected to a 16-space/circuit load center.

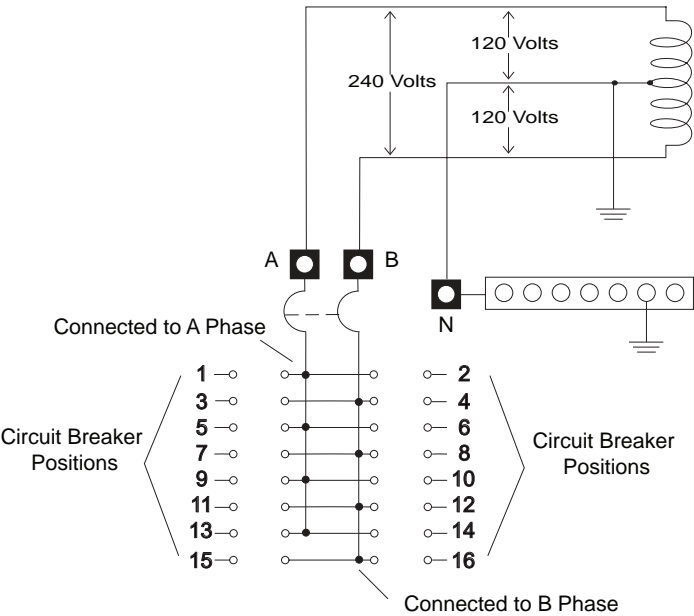

The term A phase refers to the part of a single-phase system between one hot wire and neutral. The term B phase refers to the part of a single-phase system between the other hot wire and neutral. Half of the circuits are connected to A phase and half to B phase.

For example, circuits 1 and 2 are connected to A phase; circuits 15 and 16 are connected to B phase. The number of usable circuits in this load center depends on how many 120 volt and 240 volt circuits need to be connected to it. Each 120 volt circuit will use one of the circuit breaker positions. Each 240 volt circuit will use two of the circuit breaker positions.

**120 Volt Circuit**

A circuit requiring 120 volts, such as general lighting and electrical receptacles, is connected through a 1-pole circuit breaker. In the following example a 1-pole circuit breaker has been installed in position 1. A lighting circuit receives 120 volts from A phase, through the circuit breaker and returning to the neutral connection. Power to the light can be interrupted by the light switch. There are 15 circuit breaker positions left for additional circuits.

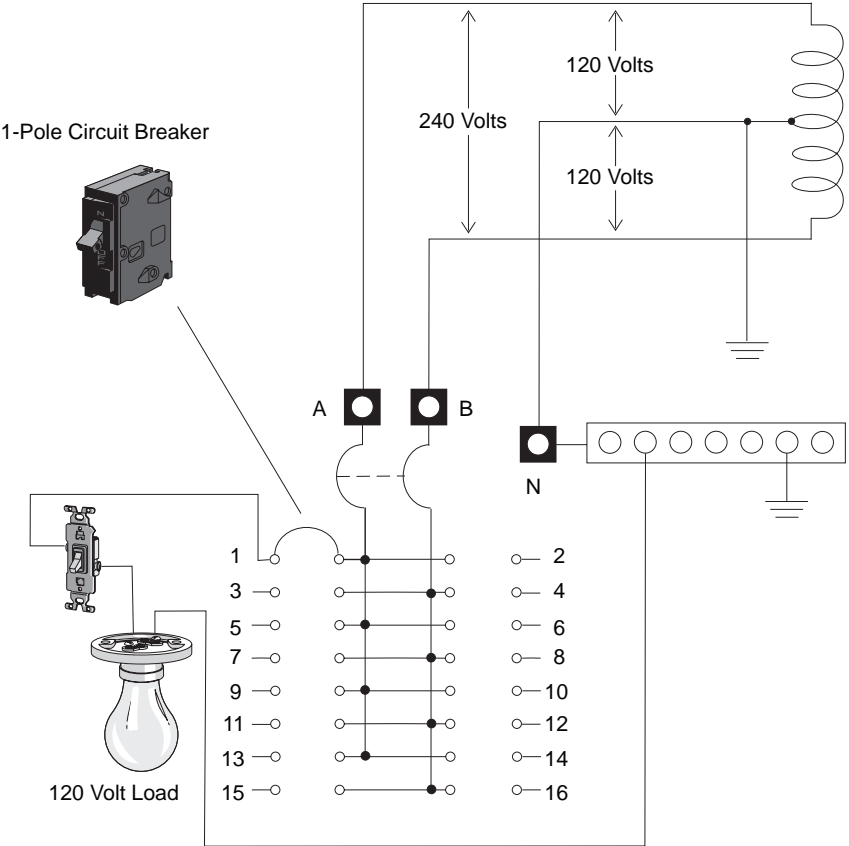

## 240 Volt Circuit

A circuit requiring 240 volts, such as an air conditioner or water heater, is connected through a 2-pole circuit breaker. In the following example a 2-pole circuit breaker has been installed in positions 1 and 3. An air conditioner receives 240 volts from phase A, through the circuit breaker pole connected to position 1, and phase B, the pole of the circuit breaker connected to position 3. This leaves 14 circuit breaker positions left for additional circuits.

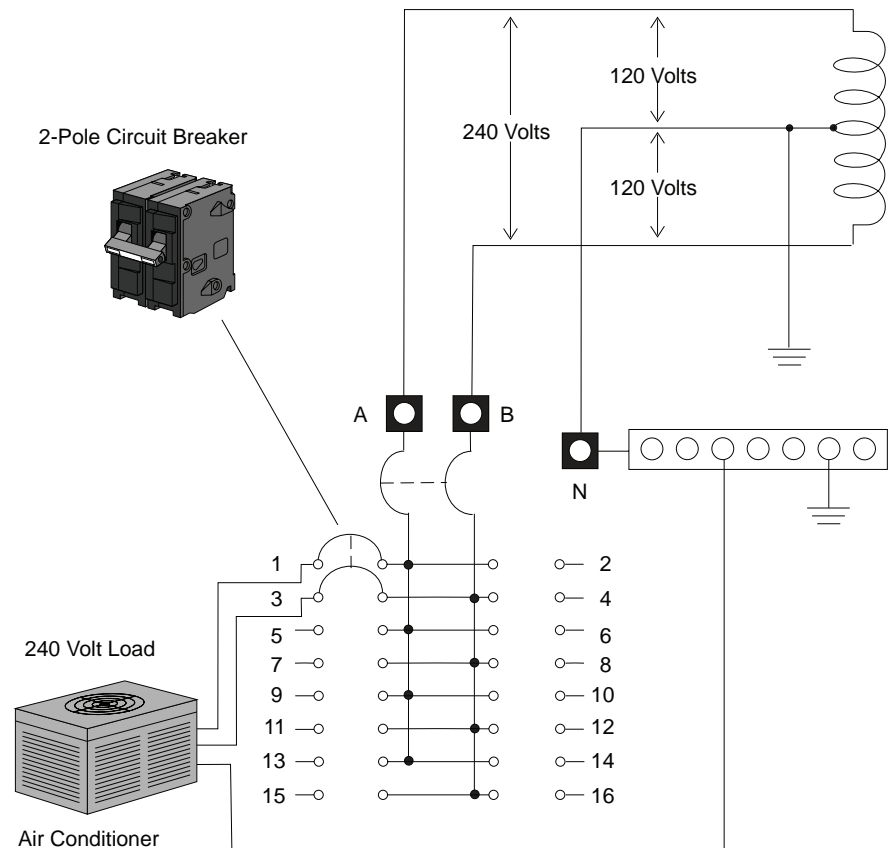

## Determining the Number of Circuits

In the following example, the number of circuits (spaces) required for a load center will be calculated using the same example to determine the load center current rating.

## General Lighting Circuits

The minimum number of lighting circuits required for general lighting is calculated first. In the sample home, the general lighting load was 6000 VA. To determine the amount of current used by a 6000 VA load, divide by the maximum voltage. The maximum voltage for general lighting is 120 volts.

$$6000 \text{ VA} \div 120 \text{ V} = 50 \text{ A}$$

Either 15 amp or 20 amp circuit breakers (with appropriately sized wiring) can be used. Typically, 15 amp circuit breakers are used for general lighting. The minimum number of circuits is calculated by dividing current by breaker size. If 15 amp circuit breakers are used, four circuits are required. Depending on the layout of lighting and receptacles, an electrician may specify more than the minimum number of circuits.

$$50 A \div 15 A = 4 \text{ circuits (3.33 rounded up to 4)}$$

### **Small Appliance Circuits**

There are three 120 volt, 20 amp small appliance loads. Three 20 amp circuit breakers are required.

### **Laundry Circuit**

There is one 120 volt, 20 amp laundry circuit. One 20 amp circuit breaker is required.

### **Air Conditioner Circuit**

Large appliances are considered individually. The air conditioner, heater, clothes dryer and range are all rated for 240 volts. Each 240 volt circuit will require a 2-pole circuit breaker which occupies two positions in the load center. The amperage is calculated by dividing VA rating by 240 volts. The air conditioner, for example, is 9600 VA.

$$9600 \text{ VA} \div 240 \text{ V} = 40 \text{ A}$$

Generally the ampere rating of a circuit breaker is selected at 125% of the continuous load current. This usually corresponds to the conductor ampacity, which is also selected at 125% of load current. The air conditioner is a 40 amp load. 50 amp wiring and a 50 amp circuit breaker would be selected.

$$40 \text{ A} \times 1.25 \text{ (125\%)} = 50 \text{ A}$$

### **Electric Heater Circuit**

The electric heater is a 240 volt, 50 amp (12,000 VA  $\div$  240 V) device.

$$50 \text{ A} \times 1.25 \text{ (125\%)} = 62.5 \text{ A}$$

Because the circuit breaker rating must not exceed the ampacity of the conductor, wiring capable of handling 70 amps should be used along with a 70 amp breaker, the next standard size above 60 amps.

### **Clothes Dryer Circuit**

The clothes dryer is a 240 volt, 21 amp (5000 VA  $\div$  240 volts) device.

$$21 \text{ A} \times 1.25 = 26.25 \text{ A}$$

30 amp wiring and a 30 amp circuit breaker should be used.



### Electric Range Circuit

The electric range is a 240 volt, 40 amp (9600 VA ÷ 240 volts) device.

$$40 A \times 1.25 = 50 A$$

50 amp wiring and a 50 amp circuit breaker would be selected.

### Dishwasher Circuit

The dishwasher and garbage disposal are 120 volt loads. The dishwasher is a 120 volt, 12.5 amp (1500 VA ÷ 120 volts) device.

$$12.5 A \times 1.25 = 15.6 A$$

20 amp wiring and a 20 amp circuit breaker should be used.

### Garbage Disposal Circuit

The garbage disposal is a 120 volt, 9.8 amp (1176 VA ÷ 120 volts) device.

$$9.8 A \times 1.25 = 12.3 A$$

15 amp wiring and a 15 amp circuit breaker should be used.

### Total Number of Spaces

The total number of load center spaces (circuits) can now be calculated. A load center with a minimum of 18 spaces are needed. Because load centers are typically selected with spare circuit breaker spaces, a **24-space load center** would be a good choice.

Circuit	Qty	Circuit Breaker	Voltage	Spaces Required
General Lighting	4	15 A	120 V	4
Small Appliance	3	20 A	120 V	3
Laundry	1	20 A	120 V	1
Air Conditioner	1	50 A	240 V	2
Electric Heater	1	70 A	240 V	2
Clothes Dryer	1	30 A	240 V	2
Electric Range	1	50 A	240 V	2
Dishwasher	1	20 A	120 V	1
Garbage Disposal	1	15 A	120 V	1
Total Spaces Required				<b>18</b>

# AC Disconnects

## Fused, Non-Fused, and Molded Case Switch Disconnects

Siemens products include fused, non-fused and molded case switch air conditioning (AC) disconnects. These are supplied in a NEMA type 3R enclosure. Both steel and plastic enclosures are available.

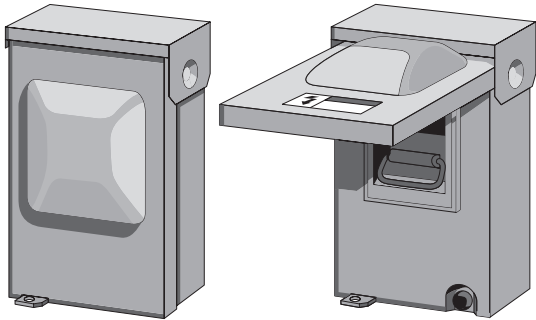

Disconnect Enclosure

Fused Disconnect

The fused pullouts are 240 volt, 2-pole, 30 or 60 amps. The non-fused pullouts are 240 volt, 2-pole, 60 amps. The molded case switch disconnects are 240 volt, 2-pole, 50 or 60 amps. Molded case switch disconnects are supplied with nonautomatic (QP molded case switch) circuit breakers.

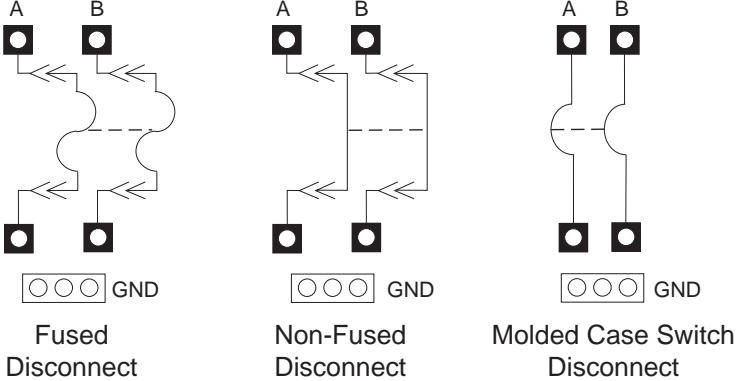

Fused Disconnect

Non-Fused Disconnect

Molded Case Switch Disconnect

# Residential Metering

For many years, power companies have used the familiar watt-hour meter to determine how much electricity has been consumed for billing purposes. Siemens manufactures a variety of metering enclosures to meet virtually every residential metering need. Siemens also manufactures metering enclosures for commercial and industrial applications, but the following paragraphs only lists the most common residential metering enclosure types.

## Residential Meter Sockets

**Single-position meter sockets** are used for single-family homes and in some commercial applications. Multiple-position meter sockets, also called **gang sockets**, are used in multi-family and other commercial applications requiring two to six meters. Requirements for meter sockets with maximum voltage ratings of 600 volts or less and continuous current ratings of 320 amps or less per socket are covered by American National Standards Institute (ANSI) standard C12.7 and UL standard 414.

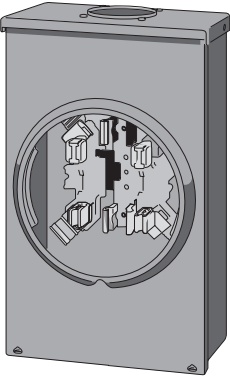

## Meter Combos

Siemens **meter combos** include two product families, meter mains and meter load center combinations. Each family is further divided into EUSERC approved and non-EUSERC products.

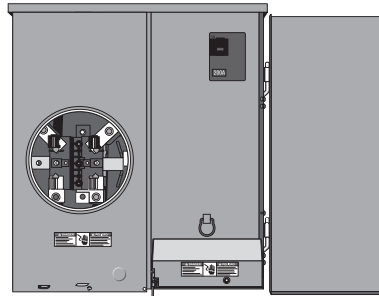

Meter Main

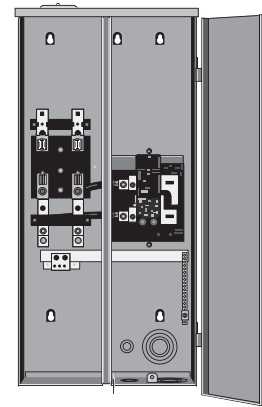

EUSERC Meter Main

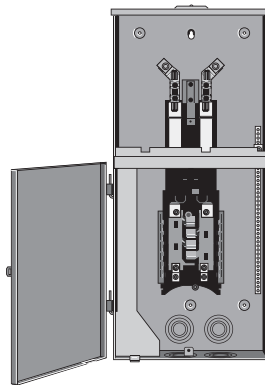

Meter Load Center  
Combination

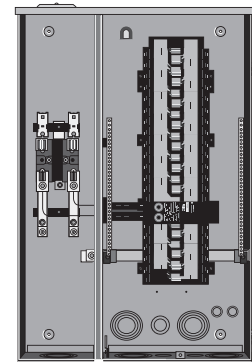

EUSERC  
Meter Load Center  
Combination

All products are UL listed as suitable for use as service entrance equipment and have padlocking provisions. Continuous current ratings for all four categories of Siemens meter combos range from 100 to 400 amps except for meter load center combinations which range from 125 to 400 amps.

Equipment Utility Service Requirements Committee (EUSERC) is an organization of approximately 80 utilities in 12 western states. One of the functions of EUSERC is to specify manufacturing and installation requirements for metering and service equipment. Utility companies dictate when EUSERC conforming equipment must be used, but EUSERC equipment can also be used in areas where it is not required by the utility.

## Meter Mains

A meter main is a meter socket combined with a main circuit breaker in one enclosure. This arrangement is sometimes required by utilities because it places the main breaker external to the residence, making it easier for service personnel to disconnect power.

All the specified information needed to select a meter socket is also needed when selecting a meter main. This includes the amperage rating, ring type, bypass type, service conductor feed (underground or overhead), and number of jaws. In addition, the frame type, continuous current rating, and interrupting rating for circuit breakers is also needed.

## Meter Load Center Combinations

A meter load center combination is a meter socket combined with a main breaker and load center. However, when only six or fewer branch circuit breakers are needed, the *NEC*<sup>®</sup> does not require a main breaker.

Meter load center combinations are gaining in popularity because having the meter socket, main breaker, and load center in one location allows contractors to save on labor and material.

## Group Metering

**Uni-Pak meter centers** are another option for multi-family dwellings. These are self-contained systems with two to six meter compartments. Individual branch circuit breakers for each tenant are located in a separate compartment adjacent to each meter socket.

**Power Mod modular metering** includes an assortment of module types that can be easily configured to meet a wide range of residential and commercial group metering applications. For example, a typical application requires a main device module and one or more residential or commercial meter stacks.

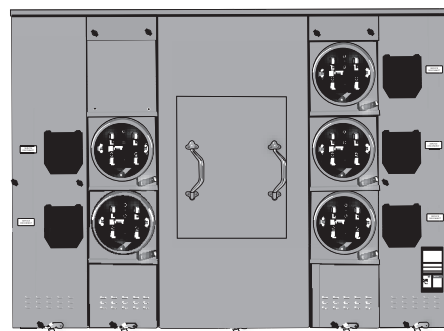

Uni-Pak Meter Center

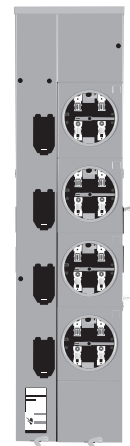

Power Mod Meter Stack

## Temporary Power Outlet Panels

The need for easily accessible receptacles to provide electrical power for various types of portable equipment continues to rise as Americans build more homes and travel in recreational vehicles (RVs). In order to satisfy the electrical power needs of temporary service and meet the requirements of the *NEC*<sup>®</sup>, a safe and reliable power outlet is required.

Siemens **All-Sites temporary outlet panels** provide a variety of options for UL listed power outlets suitable for use as temporary service equipment during construction or as recreational vehicle (RV) power supply panels.

All-Sites temporary outlet panels are available for surface mounting or on earth-mounted or pad-mounted pedestals in single panel or back-to-back configurations. Unmetered and ring type and ringless metered versions are available in all configurations.

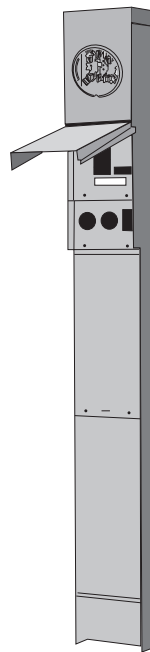

### Enclosures

- Rainproof NEMA 3R Construction
- Quality Finish
- Removable Deadfront
- Theft Resistant
- Meters Top or Bottom
- Removable Door
- Overhead or Underground Feed
- Optional Lighting

### Interiors

- Plated copper bus bars
- Internal components pre-wired
- Lifetime warranted Siemens Breakers
- Impact-resistant, Thermoplastic Receptacles
- GFCI Protection for Receptacles

## Review 7

1. Each 240 volt circuit breaker requires \_\_\_\_\_ position(s) in a load center.
2. Siemens manufactures fused, non-fused, and \_\_\_\_\_ air conditioning disconnects.
3. Multiple-position meter sockets, also called \_\_\_\_\_, are used in multi-family and other commercial applications requiring \_\_\_\_\_ to \_\_\_\_\_ meters.
4. Siemens meter combos include two product families, \_\_\_\_\_ and \_\_\_\_\_.

# Review Answers

- Review 1** 1) power distribution; 2) 408; 3) 240; 4) a; 5) d.
- Review 2** 1) 1, 3R; 2) Branch; 3) Dual neutrals; 4) Insta-wire; 5) trim; 6) circuit directory.
- Review 3** 1) heat; 2) pole; 3) main; 4) Duplex; 5) 2.
- Review 4** 1) b; 2) Arc faults; 3) d; 4) Intelli-Arc Diagnostic Tool; 5) Circuit Breaker and SPD.
- Review 5** 1) main breaker, main lug only; 2) full; 3) 6; 4) service entrance.
- Review 6** 1) PL; 2) ES; 3) Insta-wire; 4) EQ; 5) Generatory Ready; 6) riser.
- Review 7** 1) 2; 2) molded case switch; 3) gang sockets, 2, 6; 4) meter mains, meter load center combinations.

# Final Exam

Before taking the final exam, it is recommended that you delete the temporary internet files from your computer's web browser. For most versions of **Internet Explorer**, you can do this by selecting **Internet Options** from the **Tools** menu and then clicking on the **Delete Files** button. If you do not perform this step, you may see a score of 0% after you submit your exam for grading.

The final exam for this course is available online at **<http://www.usa.siemens.com/step>**. This web page provides links to all our quickSTEP online courses. To complete the final exam for this course, click on the **Basics of Load Centers** link.

Next, move your mouse over to the left so that the navigation bar pops out and select the **Final Exam** link. The final exam page will appear.

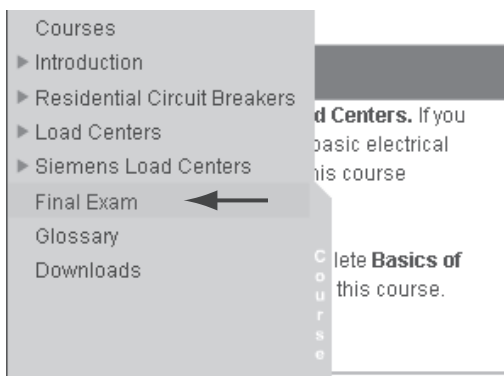

After you complete the final exam, click on the **Grade the Exam** button at the bottom of the page. Your score on the exam will be displayed along with the questions that you missed.

If you score 70% or better on the exam, you will be given two options for displaying and printing a certificate of completion. The **Print Certificate** option allows you to display and print the certificate without saving your score in our database and the **Save Score** option allows you to save your score and display and print your certificate. **The Save Score option is primarily intended for use by our distributors and Siemens employees.**