

Main Components

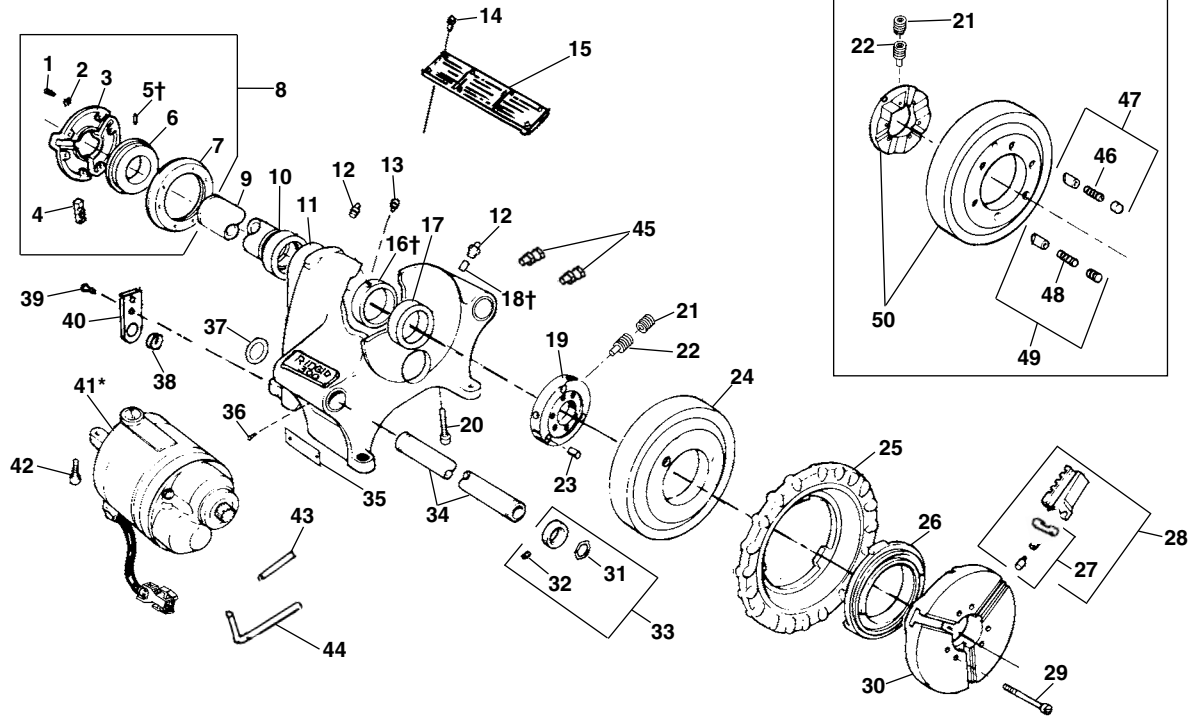

**NOTE: Order parts by Catalog Number only.
DO NOT order by Reference Number.**

For Information on Cutters, Die Heads and Reamers SEE INDEX

Ref. No.	Catalog No.	Description	Ref. No.	Catalog No.	Description
1	46790	Screw, 12 - 24 x 3/4" (6)	27	44715	Jaw Insert Set
2	40270	Lock Washer (6)		97365	Jaw Insert Set F/Coated Pipe
3	43735	Centering Head	28	44090	Chuck Jaw Set
	19346	Centering Head (Europe)	29	45295	Screw 5/16" - 18 x 2 3/4" (6)
4	46500	Rear Jaw (3)	30	43525	Cap
5†	45260	Step Pin (3)	31	44720	Snap Ring (2)
6	44095	Scroll	32	46050	Set Screw 1/4" - 18 x 1/4" (2)
7	43740	Back Plate	33	44725	Ring Assembly (2)
	19356	Back Plate (Europe)	34	44425	Support Bar (Incl. Ref. No. 37)
8	44165	Rear Centering Assembly	35	90392	FOR/OFF/REV Label
9	44100	Drive Shaft	36	45280	Screw #8 - 32 x 5/8" (2)
10	45335	Rear Bearing-Bronze	37	44525	Spring Ring (2)
11	42845	300 Body Assembly (Incl. Ref. No. 10, 11, 12, 13, 14, 15, 17, 18, 38, 39, 40)	38	46735	Cord Grommet
	19056	300A Body Assy.- Europe (Incl. Ref. No. 10, 11, 12, 13, 14, 15, 17, 18, 38, 39, 40, 43, 44, 45)	39	44735	Screw 1/4" - 20 x 5/8" (2)
	96805	300A Body Assy. (Incl. Ref. No. 10, 11, 12, 13, 14, 15, 17, 18, 38, 39, 40, 43, 44, 45)	40	45825	Strain Relief Plate
12	46860	Grease Fitting	41*	87740	3177 Motor 115V (300)
13	33785	Set Screw 5/16" - 24 x 1/4" (2)		87780	3277 Motor 230V (300)
14	85920	Pop Rivet (10)		96810	3181 Motor 115V (300A)
15	88690	Warning Plate		96975	3281 Motor 230V (300A)
16†	45345	Thrust Ring		61202	3177-CE Motor 115V (300CE)
17	45270	Front Bearing		61207	3277-CE Motor 230V (300CE)
18†	45310	Split Roll Pin		61192	3181-CE Motor 115V (300A CE)
19	30027	Drive Ring, Type II		61197	3281-CE Motor 230V (300A CE)
20	46035	Screw 5/16" - 18 x 1 3/4"	42	46745	Screw 3/8" - 16 x 1 1/4" (2)
21	45300	Set Screw 5/16" - 24 x 1/4" (2)	43	96850	Tubing (300A)
22	45265	Set Screw 5/16" - 24 x 1/2" (3)	44	96855	Tubing (300A)
23	30022	Drive Pin, Type II (3)	45	96860	Bulkhead Union (2) (300A)
24	30017	Ring Gear, Type II	46	44310	Drive Spring (3)
25	89150	Hand Wheel	47	91552	Drive Wedge Kit
26	43540	Scroll	48	45285	Pressure Spring (3)
			49	91557	Plunger Kit
			50	91562	Conversion Kit (Includes Ref. Nos. 19-24)

* Refer to Motor Model No. for Component Parts

Service Notes:

†Ref. 5 Stop Pins are easily removed by pushing from inside to outside.

†Ref. 18 Before removing front bearing sleeve (Ref. No. 17), dowel pin and grease fitting must be pushed out from inside.

†Ref. 16 Position thrust ring so that offset screw holes are closer to chuck.