

**No. 3-S**

Capacity: 2", through 3"

**No. 4-S**

Capacity: 2", through 4"

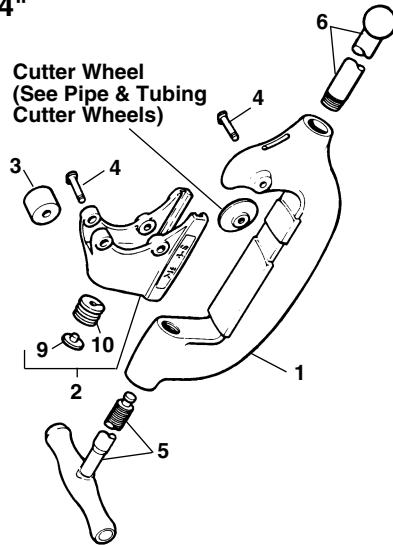

**No. 6-S**

Capacity: 4" through 6"

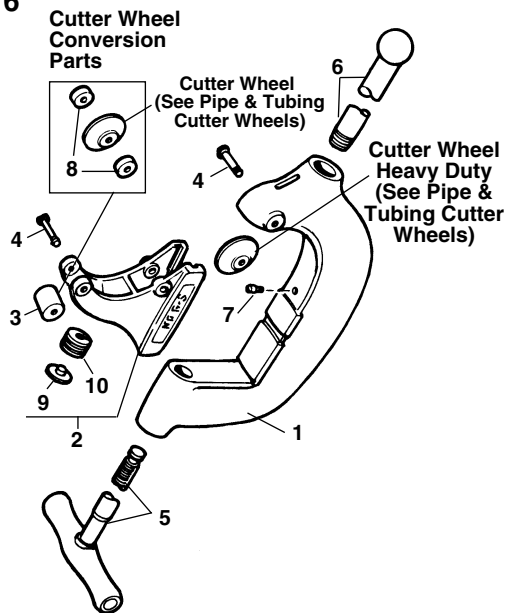

NOTE: Order parts by Catalog Number only.  
DO NOT order by Reference Number.

Ref. No.	Description	3-S 1"-3" Catalog No.	4-S 2"-4" Catalog No.	6-S 4"-6" Catalog No.
1	Frame	33285	33280	33275
2	Roll Housing	33390	33385	33300
3	Roll (2)	34785	34785	34785
4	Pin (3)	34790	34790	34790
5	Pipe Handle	33515	33515	33515
6	Screw Handle	35030	35030	35030
7	Stop Screw			34425
8	Wheel Spacer (2)			34855
9	Wear Plug	34320	34320	34320
10	Wear Plug Spring	34315	34315	34315

**No. 42-A**

Capacity: 1/2" through 2" O.D.

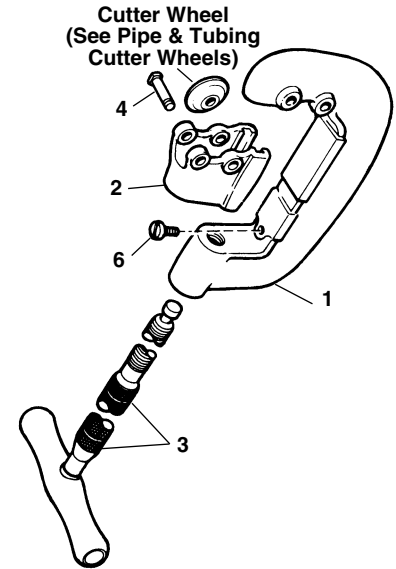

**No. 44-S**

Capacity: 2 1/2" through 4" O.D.

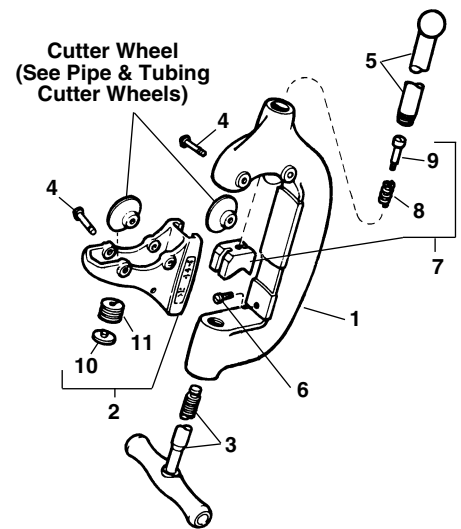

Ref. No.	Description	42-A 1/2"-2" Catalog No.	44-S 2 1/2"-4" Catalog No.
1	Frame	33295	33270
2	Cutter Wheel Housing	33455	33345
3	Screw Handle	33590	33515
4	Wheel Pin (4)	34780	34790
5	Pipe Handle		35030
6	Stop Screw	34425	34425
7	Guide Block Assembly		34840
8	Spring		34850
9	Shoulder Screw		34845
10	Wear Plug		34320
11	Wear Plug Spring		34315