

# EQUIPMENT MOUNTING

Continued

## Wall Bracket

Sliding cross bar provides exceptional width range

Code	Description	Qty.
87733 (WBB300)	Wall Bracket - powdercoat	1
87734 (WBB300SS)	Wall Bracket - stainless steel	1
87735 (WBB500)	Wall Bracket - powdercoat	1

### FEATURES

- Strong secure support • Stainless steel or powdercoat finish • Includes level for convenience

Min/Max mounting width: 9<sup>3</sup>/<sub>4</sub>" - 30"

Min/Max mounting depth: 10<sup>1</sup>/<sub>2</sub>" - 16"

Max load capacity: WBB300 - 300 lbs.

WBB300SS - 300 lbs. WBB500 - 500 lbs.



H = 18"  
W = 33<sup>1</sup>/<sub>2</sub>"  
D = 22" WBB500 = 24"

Shown in Stainless



## Wall Bracket

Extra integral cross bracing provides ultimate stability

Code	Description	Qty.
87732 (PCK30)	Wall Bracket	1

### FEATURES

- Ultimate stability • Galvanized finish

Min/Max mounting width: 15<sup>3</sup>/<sub>4</sub>" - 35<sup>1</sup>/<sub>4</sub>"

Min/Max mounting depth: 9<sup>3</sup>/<sub>4</sub>" - 15"

Max load capacity: 330 lbs.

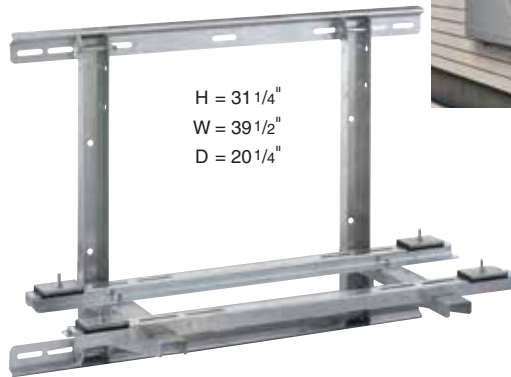

H = 31<sup>1</sup>/<sub>4</sub>"  
W = 39<sup>1</sup>/<sub>2</sub>"  
D = 20<sup>1</sup>/<sub>4</sub>"



## Under Window Bracket

Ideal for in window mounted A/C support

Code	Description	Qty.
87731 (CBZG)	Under Window Bracket	1

### FEATURES

- Strong secure support • Galvanized finish

Min/Max mounting width: 11<sup>3</sup>/<sub>4</sub>" - 27<sup>1</sup>/<sub>2</sub>"

Min/Max mounting depth: 6<sup>1</sup>/<sub>4</sub>" - 13"

Max load capacity: 176 lbs.



H = 11<sup>1</sup>/<sub>4</sub>"  
W = 29<sup>1</sup>/<sub>2</sub>"  
D = 16<sup>3</sup>/<sub>4</sub>"

