

# Gotcha! Plus

---

## Installation Manual

**GT500**



**GT500R**



## SPECIFICATIONS:

### GT500

**Voltage:**  
120V - 277VAC, 50-60Hz

**UL Listing:**  
Suitable for wet locations, raintight.

**Time Adjustment:**  
5 sec to 15 minutes

**Test Mode:**  
Set Time Adjustment knob on sensor to Test mode.

**Switching Capacity:**  
500W Incandescent @ 120V-277V  
500W LED @ 120V -277V with 0.8 pF Driver

**Power Consumption:**  
1 Watt

**Surge Protection:**  
6 KV

**Operating Temperature:**  
-4 °F to 104 °F

**Detection Zone:**  
110 degrees by 50' at 8 ft mounting height

**Warm Up Period:**  
60 Seconds

**Sensitivity Adjustment:**  
100% to 50%

**Sensor Construction:**  
Watertight precision molded Poly-Carb

**Sensor Adjustment:**  
+/- 20 Degrees Pan and Tilt

### GT500R KIT:

**PAR holder Construction:**  
Precision molded polycarbonate with molded gasket

**Cover Plate Construction:**  
Diecast Aluminum universal coverplate for surface or recessed junction box mounting.

**Sockets:**  
Medium Base

**Lamps:**  
150W Max PAR 38, not supplied

## CONTENTS:

### GT500

- 3 Wire Nuts
- Sensor



### GT500R

- Sensor assembled with (2) PAR Holders with Molded Gaskets on a universal cover plate, wired.
- Plate with foam gasket
- EZ Hang "S" Hook
- Crossbar
- Mounting Screws, Ground Screw, Plastic finishing cap
- 3 Wire nuts



## How Does Gotcha Work?

The Gotcha infrared sensor "sees" small temperature changes caused by the motion of people or cars within its Detection Zone and turns on lights automatically. It welcomes visitors and may deter intruders.

### How long do the lights stay on?

Lights remain on as long as there is movement within the Detection Zone. Once the zone is vacated, lights will remain on approximately 5 sec up to 15 minutes, depending on the time control adjustment. During initial 60 sec warm-up time, lights remain on.

### Will the sensor detect animals?

Gotcha may detect large animals. You can limit animal detection by turning down sensitivity knob or by placing opaque weatherproof tape on the lower part of the lens.

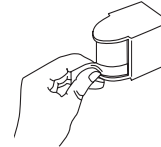

Masking the lens

### How to Manual Override Gotcha?

To Keep lights on at night, flip the wall switch two times (OFF-ON-OFF-ON) within 5 seconds. Sensor resets to auto mode after 6 hours. Switch the power ON and OFF once (OFF-ON) quickly to go to AUTO mode. No extra wiring needed.

### How are the Time, Sensitivity and Test mode adjusted?

**Time Control:** Sets the time that lights will remain on after the Detection Zone is vacated. Time setting ranges from approximately 5 seconds to 15 minutes. Turn gently. Do not turn past stops.

**Test Mode:** Turn time knob to Test setting. Complete walk test and set time to desired time setting (5 sec to 15 mins)

**Sensitivity:** Increases or decreases the responsiveness and range of the sensor.

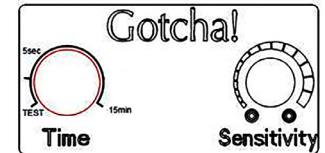

## Gotcha! Mounting and Wiring

### Cautions

- All wiring **MUST** comply with local electrical codes and should be installed by qualified electrician.
- Read entire Installation Manual before proceeding.
- **TURN OFF POWER BY REMOVING POWER FUSE OR TURNING OFF CIRCUIT BREAKER BEFORE INSTALLATION.**
- Total lighting load to Gotcha must not exceed:  
500W incandescent @ 120V-277V  
500W LED @ 120V-277V with 0.8 pF Driver
- Line Carrier Remote Control Systems such as X-10, Leviton or Radio Shack are incompatible with sensors and can cause false activations.
- Do not install on circuits feeding motor loads such as kitchen appliances, HVAC equipment, washer/ dryer or garage door openers.
- Sensor functions best when movement is across its detection pattern, not towards the sensor.
- Mount 6'-12' high for optimum range and direction.

**To switch more wattage, an electrician can install an additional relay.**

### Mounting(GT500R)

Gotcha floodlight kits come pre-wired and assembled on the RAB CU4 EZ plate, allowing for mounting on round, rectangular or octagonal surface or recessed box.

#### GT500R Surface Junction Box Installation:

1. Attach **Cross Bar** to **Surface Junction Box** using three bar screws (supplied).
2. Bring sensor wires through the **Surface Adaptor Plate**.
3. Make connections to the supply wires in the junction box according to the "Basic Kit Wiring" diagram on pg 5.
4. Push connected wires into the **Surface Junction box**.
5. Place the **O-Ring** over the **1/4-20 Screw** and insert into the center of the cover plate and tighten. Use **Cap** to cover opening.

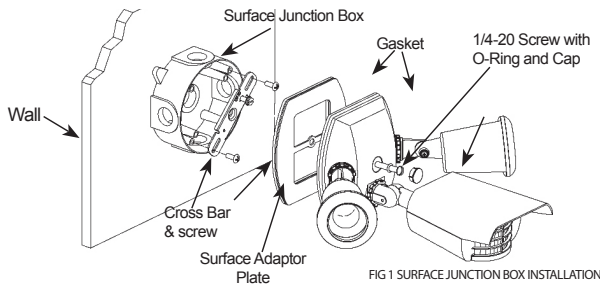

FIG 1 SURFACE JUNCTION BOX INSTALLATION

#### GT500R Recessed Junction Box Installation:

1. Discard the **Surface Adaptor Plate** when mounting to a **Recessed Junction Box**.
2. Attach **Cross Bar** to junction box using the screws supplied.
3. Make connections to the supply wires in the junction box according to the "Basic Kit Wiring" on pg 5.
4. Push connected wires into junction box.
5. Place the **O-Ring** over the **1/4-20 Screw** and insert into the center of the cover plate and tighten. Use **Cap** to cover opening.

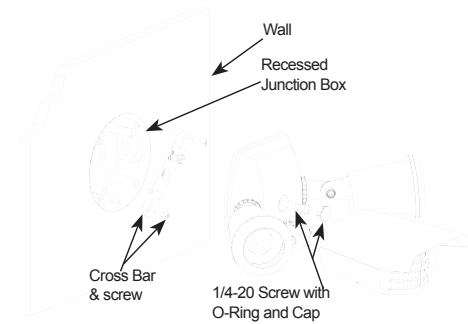

FIG 2 RECESSED JUNCTION BOX INSTALLATION

#### GT500 Sensor with separately purchased floodlights:

1. Mount sensor to 1/2" NPS hole of a RAB CU4 EZ weatherproof coverplate (not provided).
2. Mount fixtures (not provided) to coverplate or locate remotely.
3. Wire as shown in "Basic Wiring Diagram" on pg 5.



FIG 3 RAB CU4 EZ WEATHERPROOF COVERPLATE

## Basic Kit Wiring (GT500R)

### Easy Wiring Tip:

Use "S" shaped EZ Hang Hook to hold the cover plate and sensor for hands free wiring.

- Strip incoming supply wires 3/8" to 1/2".
- Make connections shown left of the dotted line.
- The Red Pigtail is only used if you are remotely switching additional fixtures.

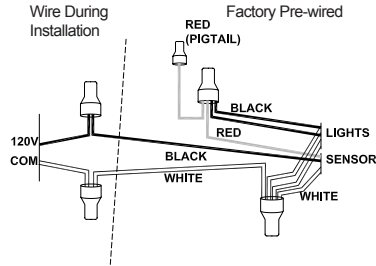

## Basic Wiring Diagram (GT500)

- Strip all wires 3/8" to 1/2".
- Wire as shown.

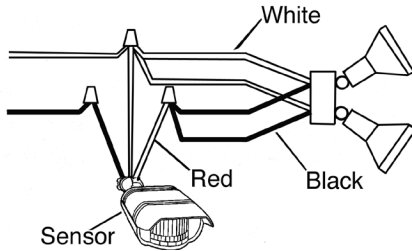

## Multiple Fixtures

- Do not switch loads greater than 500W without installing a relay suitable for your load.
- Wiring more than one sensor together is recommended only for the experienced installer because it becomes difficult to troubleshoot. Single sensors that control their own lights pinpoint movement more accurately and operate better.

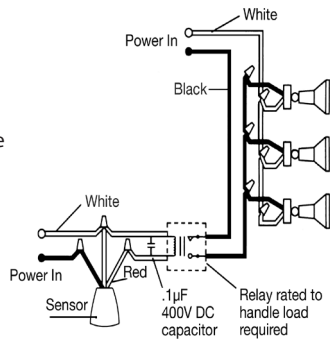

## Picking A Location

### Location Considerations:

- Choose a location from which the sensor can "see" all the paths of movement that will be illuminated by its lights.
- If wall mounting, locate 8-10' high for optimum range and detection. Lower mounting height will reduce range. Sensor must be below and as far as possible away from lights.
- Mount on stable surface that is protected from rain.

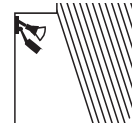

- Do not mount on a pole or tree that sways in the wind.

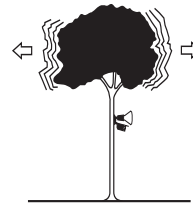

- Sensor functions best when the direction of expected movement is across its detection pattern, not towards the sensor.

### Detection Pattern

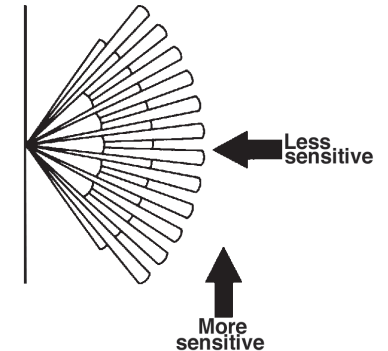
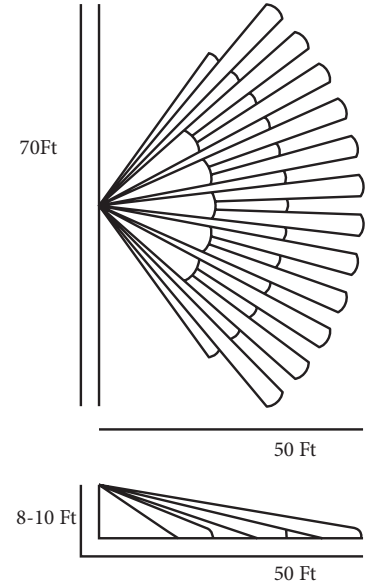

## Aiming and Walk Testing

### Test Period:

The sensor has a Test mode which allows it to be aimed and walk tested day or night.

- Switch the sensor to Test mode by adjusting the time control to test setting. Power on sensor.
- During the 60 second warm up period, the lights will be turned on. During this time, test that all fixtures and lamps function properly.
- After the warmup period, the sensor will keep lights on for 5 seconds each time it detects movement in its Detection Zone.
- Once the Detection Zone is tested, adjust the sensor Time control to desired standby time.

### Walk Test:

The purpose of the Walk Test is to check and adjust the coverage pattern.

1. Aim the sensor approximately to cover the area you desire.
2. Start outside the Detection Zone and walk across the zone until the lights go on. As distance from the sensor increases, it will take more movement to be detected. For instance, at 10 feet, a half step will be enough, while at 30 feet, several steps will be necessary.
3. To reduce range tilt sensor down. Repeat steps #2 and #3 until you are satisfied with the coverage.
4. After testing is complete, adjust the time setting to desired setting by turning time control knob (5 sec to 15 mins).
5. Your sensor is ready for operation. See the Technical Tips pages if additional help is needed.

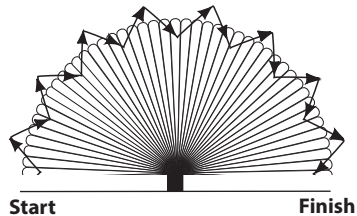

## Troubleshooting

### Technical Tips: Lights Do Not Turn Off

1. Make sure sensor is not aimed at something that would move or change temperature such as waving branches, water, air conditioners, windows or heating vents - even on neighboring property. You can test for infrared sources in the area by placing a box or bag over the sensor. Put sensor into Test Mode. After the initial 60 seconds of the lights being on, lights should stay off. Wave your hand inside the bag in front of sensor. Lights should go on and then time out. If sensor operates properly when covered, check items 2-6.

**Problem:** Sensor is triggered by unwanted movement or heat source.

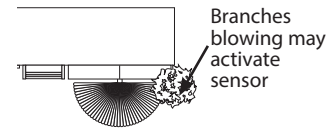

**Solution:** Tilt sensor or mask lens in the direction of the source. Move sensor or source.

2. Make sure sensor is mounted firmly and does not move even slightly when touched. If it moves, tighten all screws.
3. Make sure that Sensor is not mounted on an unstable object such as a tree or a pole that will move in the wind.
4. Was sensor wired hot? If so, circuitry may have been damaged.
5. Make sure sensor is not aimed within 30 feet of a road.

**Problem:** Passing cars activate sensor.

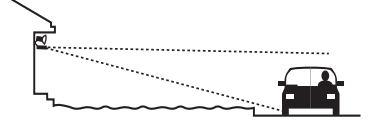

**Solution:** A 20' safety zone between the sensor and road is recommended to avoid activation from passing cars.

You may tilt sensor to not aim in the direction of the street or mask top of sensor lens to reduce range (Pg. 8)

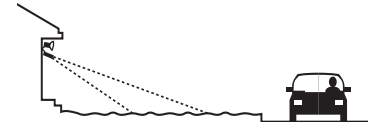

6. Make sure heat from lights is not triggering sensor. Make sure the sensor is below and as far as possible away from lights.
7. Make sure sensor is not in initial 60 sec warm up period. Warm up period will activate every time power is turned off and re-applied to sensor.

## Technical Tips: Lights Do Not Turn On

1. Check that lamps and fixtures work. Compare wiring to the Wiring Diagram in this manual. Check that the power is on.
2. Check that lights from other sources, such as adjacent porch lights, garden lights, streetlights or lights from inside the house are not in the sensor's view. See #1 under "Lights Turn Off Too Quickly".
3. Was sensor wired hot? If so, circuitry may have been damaged.
4. If sensor is painted, make sure there is no paint on the lens and that the lens paint mask is removed.
5. Check that time adjustment control is not set past 15 min mark.

## Lights Turn Off Too Quickly

1. Make sure the Time control is not set to test mode or set to the minimum setting which would be 5 seconds. Change time setting on knob on bottom of the sensor.

## Technical Tips: Range appears limited

1. Check that the sensor is level from side to side and pointed at the area you desire. If unit is tilted, part of the Detection Zone may be high in the air over people's heads.

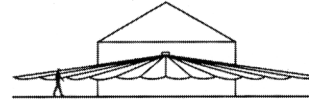

**Solution:** Position sensor exactly level from side to side.

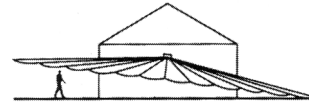

2. Check that the sensor is not mounted too high. If mounted above 20 feet, much of the usable range will be lost.

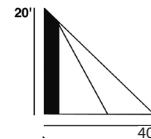

**Solution:** Mounting at 8' to 10' allows maximum range.

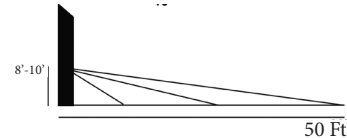

3. If sensor is painted, make sure there is no paint on the lens and that the lens paint mask is removed.

## Technical Tips: Lights Turn On and Off Incorrectly

1. Make sure the sensor is installed on its own dedicated circuit free of motor loads such as HVAC equipment, kitchen appliances or garage door openers.
2. It is not recommended to wire sensors in parallel. More than one sensor wired together makes them difficult to troubleshoot. Disconnect multiple sensors and test separately.
3. Keep all people completely out of the detection pattern to make sure the sensor is not detecting them.
4. Make sure sensor is located below and as far as possible from its lights. Heat from the lights may trigger the sensor.



**Solution:** Move sensor below and away from the lights.

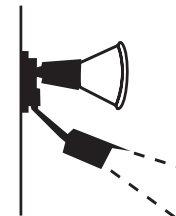

## RAB Sensor Warranty

5. Make sure lights are not visible from or reflecting back into sensor. Check for white or reflective surfaces close to the sensor.

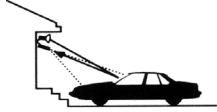

**Solution:** Aim sensor away from lights and reflective objects or mask the lens in the direction of the light or reflection.

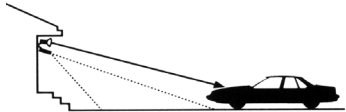

6. Heavy rain, snow or high winds may activate the sensor occasionally.

**Solution:** Reduce sensitivity control settings, mount in a more protected area and/or mask the lens if this is a constant problem.

7. Make sure sensor is not aimed within 30' of a road or sidewalk. Passing cars will activate sensor.



**Solution:** Mask the top of the lens to reduce Detection Pattern Length.

8. Self ballasted PL lamps may cause cycling (on-off).
9. Check solutions 1, 2, 3, 5 & 6 under "Lights Do Not Turn Off" (Pg. 10).

The GT500 AND GT500R Sensor will be free from defects in materials and workmanship for a period of five (5) years from the date of delivery to the end-user.

Sensors must be installed by a properly insured and licensed electrician or under the supervision of a licensed electrician and the product must be in its original, unopened and new condition at the time of installation. The information provided in the RAB Sensor Owner's Manual is critical in determining the location, conditions, intended use and other requirements with respect to the use and installation of a sensor product. Using a sensor product in any manner other than as disclosed in the RAB Owner's Manual automatically voids the warranty.

Exceptions. The above warranties shall not apply and RAB makes no representations or warranties with respect to:

- problems caused by acts of God including without limitation lightning strikes; and
- problems caused by any improper action or failure to act by any person or entity other RAB, including without limitation problems caused by improper installation by the buyer, an authorized RAB distributor, or any other person or entity; and
- using or installing a sensor product in any manner other than as disclosed in the RAB Owner's Manual.
- use with Instant Start ballasts; use with Instant Start ballasts will void the RAB warranty.

Out of warranty sensors replacement program. If your sensor is out of warranty or if damage is unrelated to its original manufacture, return your sensor (freight prepaid and insured) directly to us (at RAB Lighting Inc. 170 Ludlow Ave. Northvale, NJ 07647) with a check for \$20.00 made payable to RAB Lighting Inc. We will repair or replace your sensor promptly.

## RAB Lighting Product Warranties

The following warranties apply to RAB Lighting, Inc. ("RAB") products that meet all of the following conditions: (a) the product was purchased by the contractor or end-user from an authorized RAB distributor who purchased the product directly from RAB and from no other source; (b) if the product has been installed, the entire installation was performed by a licensed electrician or under the supervision of a licensed electrician and the product was in its original, unopened and new condition at the time of installation. RAB LIGHTING DISCLAIMS ALL REPRESENTATIONS AND WARRANTIES WITH RESPECT TO ALL OTHER PRODUCTS, INCLUDING WITHOUT LIMITATION PRODUCTS THAT HAVE BEEN PURCHASED FROM ANY PERSON OR ENTITY OTHER THAN AN AUTHORIZED RAB DISTRIBUTOR, OR INSTALLED BY ANY PERSON OR ENTITY OTHER THAN A LICENSED ELECTRICIAN OR UNDER THE SUPERVISION OF A LICENSED ELECTRICIAN, AND ALL PRODUCTS THAT ARE USED OR ARE OTHERWISE NOT IN THEIR ORIGINAL RAB LIGHTING PACKAGING AT THE TIME OF INSTALLATION.

**Remedy.** RAB's obligations for breach of warranty shall be limited to repair or replacement, at RAB's option, of any products or parts which prove to be defective, provided that buyer gives RAB written notice and returns the defective product to RAB in accordance with RAB's return material authorization (RMA) policies, and RAB confirms the defect. Buyer is responsible for all costs to de-install defective products and re-install replacement or repaired products and RAB shall not be liable for labor or other costs related to de-installation or re-installation.

**DISCLAIMER.** THE FOREGOING WARRANTIES ARE IN LIEU OF, AND RAB EXPRESSLY DISCLAIMS, ALL OTHER REPRESENTATIONS, GUARANTEES AND WARRANTIES, EXPRESS OR IMPLIED IN FACT OR BY LAW, INCLUDING WITHOUT LIMITATION ALL WARRANTIES OF MERCHANTABILITY OR FITNESS FOR A PARTICULAR PURPOSE OR OTHERWISE. THE FOREGOING WARRANTIES STATE RAB'S ENTIRE AND EXCLUSIVE LIABILITY, AND BUYER'S SOLE AND EXCLUSIVE REMEDY, IN CONNECTION WITH THE PRODUCTS AND ALL PARTS, THEIR DESIGN, SUITABILITY FOR USE, INSTALLATION AND OPERATION.

**LIMITATION OF LIABILITY.** RAB shall not be liable under any theory of relief, including without limitation breach of warranty, breach of contract, tort (including negligence), strict liability, or otherwise, arising out of or related to any breach of warranty, any RAB products and the use thereof, or any other acts or omissions of RAB for: (i) any indirect, incidental, special or consequential damages, whatsoever (including without limitation, loss of anticipated value of a business or its reputation) or (ii) any damage or loss in excess of the price actually paid by buyer to the authorized RAB distributor for the products that caused the damages. Any action by buyer must be commenced within one year after the cause of action has accrued.

**Miscellaneous.** These product warranty terms shall be governed by the laws of the State of New York. Buyer consents to the personal jurisdiction and venue of the courts of the State of New York. Any legal or equitable claim of any nature arising hereunder shall be filed and maintained in the state or federal courts in the State of New

York and buyer agrees that such courts are a convenient forum for adjudication. In the event that suit is necessary to recover amounts owed RAB, buyer shall be liable for reasonable attorney's fees, interest and costs of collection. No agreement or understanding varying the terms and conditions hereof shall be binding upon RAB or buyer unless in writing and signed by duly authorized representatives of both parties. These product warranty terms shall inure to the benefit of and be binding upon the parties hereto and their respective successors and assigns.

## Toll Free Technical Assistance

If you need technical assistance, please do the following:

1. Re-read the Technical Tips sections of this manual.
2. Call the Tech Help Line at 888 722-1000, 8AM to 4PM Eastern Time M-F and we will be glad to help you. Before you call, please have the following information handy:

- a) Catalog number of your unit;
  - b) Wattage, types and locations of lights connected to the sensor;
  - c) The electrical circuit on which the sensor is installed...what else does it feed? How is the sensor power switched?
  - d) This installation manual.
- Note: RAB Lighting cannot give electrical wiring instructions by phone. Please consult a qualified electrician.

*Note: These instructions do not cover all details or variations in equipment nor do they provide for every possible situation during installation operation or maintenance.*