



QF2X500T



JOB NAME: _____
 DATE: _____
 TYPE: _____

DESCRIPTION

Telescoping double reinforced tripod stand with twin powerful 500 watt work lights. High quality on/off switch, tempered glass, extra depth wire guard and 12' power cord with grounded plug. Two 500 watt lamps included (130 volt for extended life).

SPECIFICATIONS

Finish:

Chip & fade resistant epoxy powder coating

Housing:

Precision die cast aluminum

Lens Gasket:

High temperature tubular silicone set in retaining groove to remain in place during relamping

Lens:

Tempered, shock resistant glass

Power Cord:

Heavy duty rubber clad with grounded plug

Reflector:

Pebbled, anodized aluminum

Socket:

Porcelain with spring loaded contacts

UL Listing:

Suitable for wet locations

Color:

Safety yellow

Patents:

RAB sensor and fixture designs are protected under U.S. and International Intellectual Property laws

Weight:

13.35

DIMENSIONS

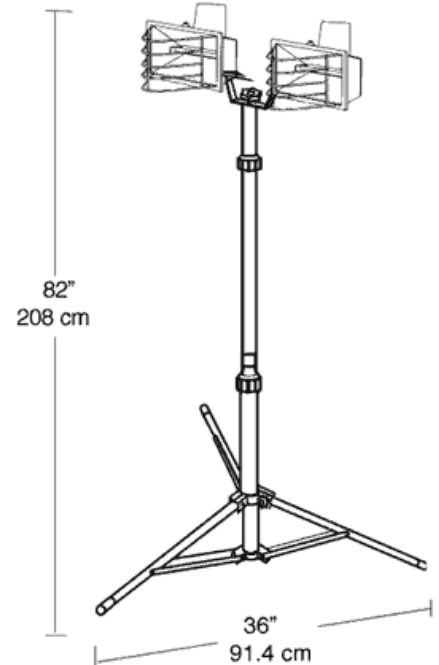

ORDERING INFORMATION

Double Ended Quartz Halogen
 Lamp supplied with fixture

Total Watts	Lamp Type	Lamp Base	Ballast
500	T3	Double Ended	RSC

Starting Amps/ Operating Amps			
120V	208V	240V	277V

Input Watts	LAMP ANSI	Initial Lumens	Lamp Hours
0	0	10500	2000

Factory Installed Options
 Add suffix to Catalog Number

Note: Specifications may change without notice