

INSTALLATION INSTRUCTIONS

Ventilating Fan

Model No. FV-0511VKL2

ftp://ftp.panasonic.com/ventilationfan/installation/FV-0511VKL2_en_install.pdf

FV-0511VKSL2

Representative models:

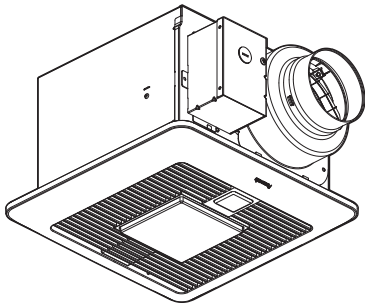

FV-0511VKSL2 FV-0511VKL2

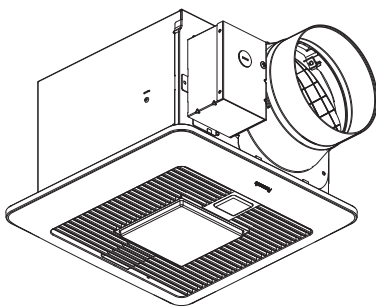

FV-1115VKL2

Contents

| | |
|--|------------|
| GENERAL SAFETY INFORMATION | 2-3 |
| PLEASE READ PRIOR TO INSTALLING THIS FAN | 3-4 |
| DESCRIPTION | 4 |
| UNPACKING | 5 |
| SUPPLIED ACCESSORIES..... | 5 |
| DIMENSIONS | 5 |
| WIRING DIAGRAM | 5 |
| FEATURE | 6 |
| INDICATION (PLUG 'N PLAY FUNCTION DEVICES) | 6-7 |
| MOTION (PLUG 'N PLAY FUNCTION DEVICES) | 7 |
| INSTALLATION (PLUG 'N PLAY FUNCTION DEVICES) | 8 |
| INSTALLATION (NEW CONSTRUCTION) | 8-10 |
| INSTALLATION (RETROFIT) | 10 |
| MAINTENANCE (CLEANING) | 11 |
| PRACTICAL GUIDE TO INSTALLATION | BACK COVER |
| SPECIFICATIONS | BACK COVER |
| PRODUCT SERVICE | BACK COVER |

READ AND SAVE THESE INSTRUCTIONS

Thank you for purchasing this Panasonic product.

Please read these instructions carefully before attempting to install, operate or service the Panasonic product. Please carefully read the "GENERAL SAFETY INFORMATION". Failure to comply with instructions could result in personal injury or property damage. Please explain to users how to operate and maintain the product after installation, and this booklet should be presented to users.

Please retain this booklet for future reference.



GENERAL SAFETY INFORMATION

For Your Safety

To reduce the risk of injury, loss of life, electric shock, fire, malfunction, and damage to equipment or property, always observe the following safety precautions.

Explanation of symbol word panels

The following symbol word panels are used to classify and describe the level of hazard, injury, and property damage caused when the denotation is disregarded and improper use is performed.



Denotes a potential hazard that could result in serious injury or death.



Denotes a hazard that could result in minor injury.



Denotes a hazard that could result in property damage.

The following symbols are used to classify and describe the type of instructions to be observed.



This symbol is used to alert users to a specific operating procedure that must be followed in order to operate the unit safely.



This symbol is used to alert users to a specific operating procedure that must not be performed.



This symbol is used to alert users not to disassemble the equipment.



This symbol is used to alert users to make sure of grounding when using the equipment with the grounding terminal.



To reduce the risk of fire, electric shock or injury to persons, observe the following :



Use this unit only in the manner intended by the manufacturer. If you have any questions, contact the manufacturer.



Before servicing or cleaning unit, switch power off at service panel and lock the service disconnecting means to prevent power from being switched on accidentally. When the service disconnecting means cannot be locked, securely fasten a prominent warning device, such as a tag, to the service panel.



Installation work and electrical wiring must be done by qualified person(s) in accordance with all applicable codes and standards, including fire-rated construction.



Sufficient air is needed for proper combustion and exhausting of gases through the flue (chimney) of fuel burning equipment to prevent back drafting. Follow the heating equipment manufacturer's guideline and safety standards such as those published by the National Fire Protection Association (NFPA), and the American Society for Heating, Refrigeration and Air Conditioning Engineers (ASHRAE) and the local code authorities.



When cutting or drilling into wall or ceiling, do not damage electrical wiring and other hidden utilities.



Ducted fans must always be vented to the outdoors.



If this unit is to be installed over a tub or shower, it must be marked as appropriate for the application and be connected to a GFCI (Ground Fault Circuit Interrupter) - protected branch circuit.









These models are UL listed for tub and shower enclosures.











Not to be installed in a ceiling thermally insulated to a value greater than R60.

GENERAL SAFETY INFORMATION CONTINUED





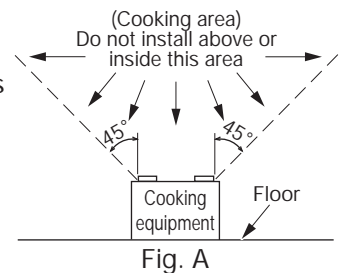

-  Do not disassemble the unit for reconstruction. It may cause fire or electric shock.
-  A statement to the effect that when the product is to no longer be used, it must not be left in place but remove, to prevent it from possibly failing.
-  Ceiling joist must be subjected to static load more than five times the weight of the product.
-  Do not install with a method which is not approved in the instructions.
-  Do not use this fan with any solid-state speed control device. Solid state controls may cause harmonic distortion which can cause motor humming noise.
-  This product must be properly grounded.

CAUTION

-  Do not install this ventilating fan where interior room temperature may exceed 104°F (40°C)
-  Make sure that the electric service supply voltage is AC 120V, 60Hz.
-  Follow all local electrical and safety codes, as well as the National Electrical Code (NEC) and the Occupation Safety and Health Act (OSHA).
-  Always disconnect the power source before working on or near the fan, motor or junction box.
-  Protect the supply wiring from sharp edges oil, grease, hot surfaces, chemicals or other objects.
-  Do not kink the supply wiring.
-  For general ventilating use only. Do not use to exhaust hazardous or explosive materials and vapors.
-  Not for use in cooking area. (Fig.A)
-  The special-purpose or dedicated parts, such as mounting fixtures, must be used if such parts are provided.

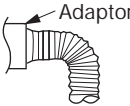

NOTICE

-  Provide make up air for proper ventilation.
-  Do not install the unit where ducts are configured as shown in below.
 -  Excessive bending
 -  Successive bending
 -  Squeezed duct
 -  Bend close to duct adaptor
-  When one switch is connected with two or more products in parallel, the unit may not function. Therefore, parallel connection should not be allowed.

PLEASE READ PRIOR TO INSTALLING THIS FAN

Spot and Continuous Ventilation: These fans are designed to run continuously ensuring a healthy environment at low CFM levels 24 hours a day. By utilizing the optional CustomVent Multi-Speed

PLEASE READ PRIOR TO INSTALLING THIS FAN CONTINUED

module the fans are built to run continuously at a pre-set lower level (FV-0511VKSL2 and FV-0511VKL2: 0,30,40, 50, 60, 70, 80, 90, 100 CFM; FV-1115VKL2: 0, 50, 60, 70, 80, 90, 100, 110, 120 CFM). The setting is dependent on the size of the house and the individual wishes of the homeowner. It is crucial that the installer pre-set the lower setting during the installation. Please refer to the chart below and the switch indication on page 6.

CustomVent Multi-Speed module (Lower Setting). ASHRAE 62.2-2016

| (sq.foot) | Two Bedrooms | Three Bedrooms | Four Bedrooms | Five Bedrooms |
|-----------|--------------|----------------|---------------|---------------|
| < 500 | 38 | 45 | 53 | 60 |
| 501-1000 | 53 | 60 | 68 | 75 |
| 1001-1500 | 68 | 75 | 83 | 90 |
| 1501-2000 | 83 | 90 | 98 | 105 |
| 2001-5500 | 98 | 105 | 113 | 120 |
| 2501-3000 | 113 | 120 | 128 | 135 |
| 3001-3500 | 128 | 135 | 143 | 150 |
| 3501-4000 | 143 | 150 | 158 | 165 |
| 4001-4500 | 158 | 165 | 173 | 180 |
| 4501-5000 | 173 | 180 | 188 | 195 |

These fans are also built to take care of the homeowner's spot ventilation needs when the room is occupied. The basic fan models allow a choice of three speeds. When fans are equipped with the optional Multi-Speed module, these models increase to a maximum level of 150 CFM for the FV-1115VKL2 and 110 CFM for the FV-0511VKSL2 and FV-0511VKL2 either when the switch is turned on or activated by the optional Condensation Sensor module or the optional Motion Sensor module.

A High/Low Delay Timer, located inside the fan unit, is utilized to return the fan back to the pre-set continuous ventilation mode. The installer needs to consult with the homeowner for the desired setting on the timer (0 - 60 minutes) and make the adjustments during the installation.

DESCRIPTION

These products are listed by UL under UL file No. E78414.

These products use a sirocco fan driven by a DC motor powered by an integral transformer. The motor is designed to have long operating life, high dynamic response, higher speed ranges with saving energy. The grille covering the fan body is a spring-loaded, quick remove type. A damper for preventing air counter flow is provided. The blower uses a high-capacity sirocco fan developed to reduce the noise level. The lighting unit is an energy-saving LED lighting device that uses one 10W LED lamp and produces almost the same illumination as a standard 40W incandescent lamp. Night light feature consumes around 0.1 to 0.4 W.

FCC Note: This equipment has been tested and found to comply with the limits for a Class B digital device, pursuant to Part 15 of the FCC Rules. These limits are designed to provide reasonable protection against harmful interference in a residential installation. This equipment generates, uses and can radiate radio frequency energy and, if not installed and used in accordance with the instructions, may cause harmful interference to radio communications. However, there is no guarantee that interference will not occur in a particular installation. If this equipment does cause harmful interference to radio or television reception, which can be determined by turning this product on and off, the user is encouraged to try to correct the interference by one of the following measures:

- Reorient or relocate the receiving antenna.
- Increase the separation between the equipment and receiver.
- Connect equipment into outlet on a circuit different from that to which the receiver is connected.
- Consult the dealer or an experienced radio/TV technician for help.

Warning: This equipment must be installed by qualified person in accordance with the provided installation instructions; and all applicable codes and standards. Also, any changes or modifications not expressly approved by the party responsible for compliance could void the user's authority to operate this equipment.

DoC Responsible Party: Panasonic Corporation of North America
Two Riverfront Plaza, Newark, NJ 07102

Customer Call Support: 1-866-292-7299

This device complies with Part 15 of the FCC Rules. Operation is subject to the following two conditions: (1) This device may not cause harmful interference, and (2) this device must accept any interference received, including interference that may cause undesired operation.



Risk of Fire: Type IC-Inherently Protected.

UNPACKING

Unpack and carefully remove the unit from packing.
Refer to the Supplied Accessories list to verify that all parts are present.

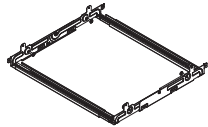
SUPPLIED ACCESSORIES

| Part name | Appearance | Quantity |
|--|---|----------|
| Grille |  | 1 |
| Flex-Z Fast™ bracket (with 4 tapping screws -ST4.2X20) |  | 1 |

| Part name | Appearance | Quantity |
|---------------------------|---|----------|
| Warranty sheet |  | 1 |
| Installation instructions |  | 1 |
| Self-drilling screw |  | 4 |

DIMENSIONS

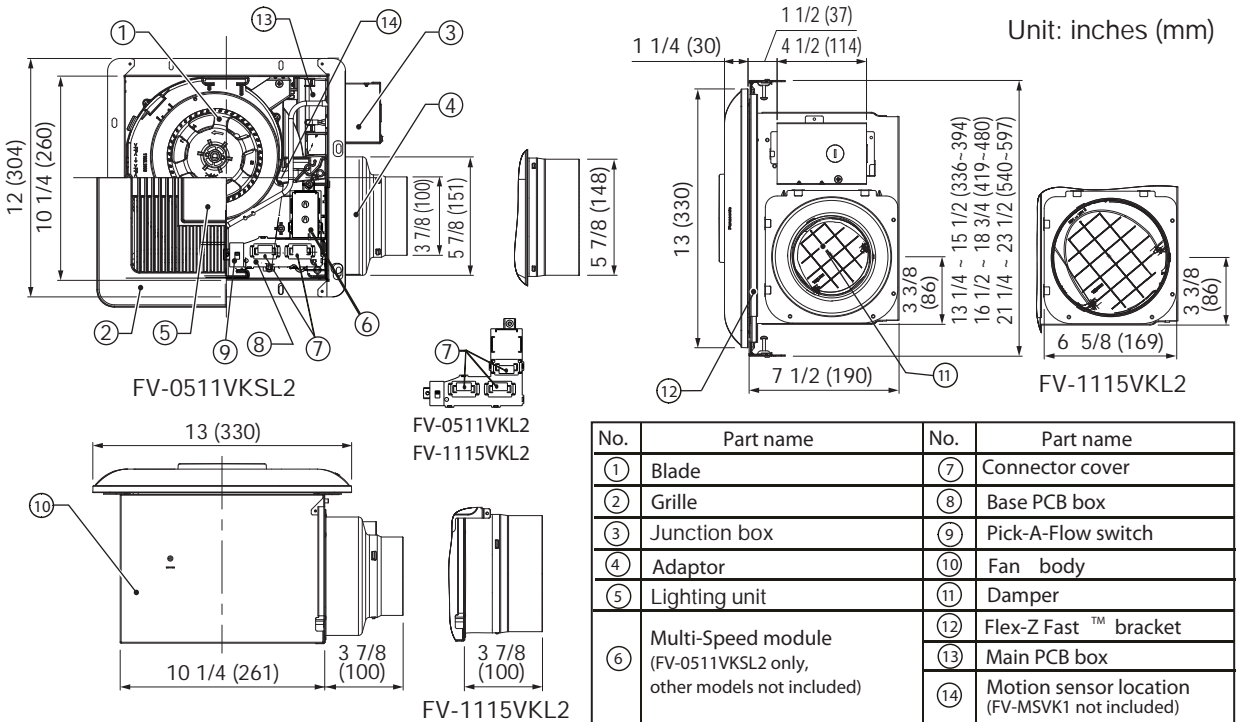

WIRING DIAGRAM

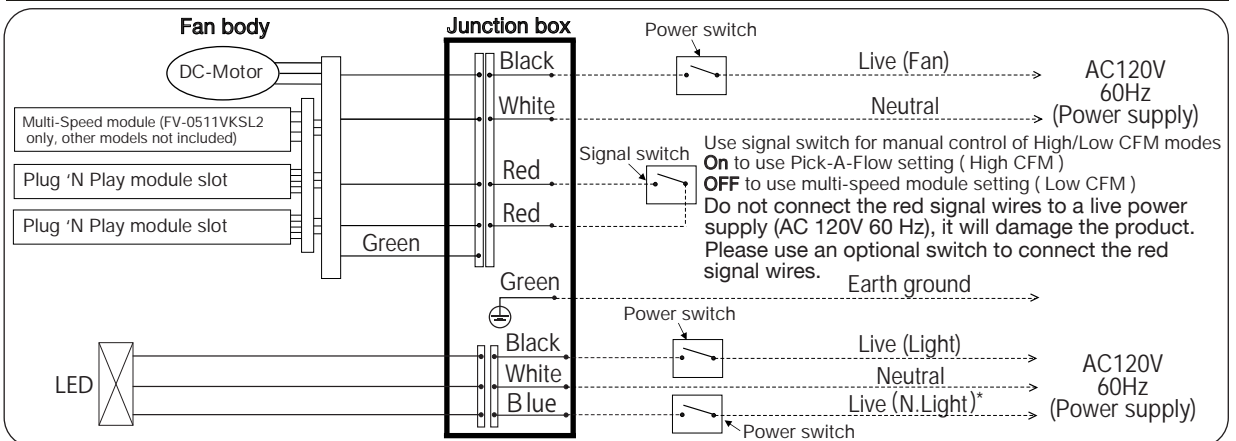

*Night light

FEATURE

Optimum Ventilation Performance:

Duct length, elbows and other factors increase static pressure which can hinder the performance of most ventilation fans. This fan utilizes Smart Flow microchip technology that monitors the static pressure in the system and speeds up or slows down the RPM of the fan depending upon the amount of resistance within the ducts. This feature allows the fan to perform as rated and avoid potential installation issues.

Outstanding Energy Savings:

The WhisperGreen Select Line of fans are built using DC motor technology. The DC motor is 30% - 70% more energy efficient than the minimum ENERGY STAR requirements.

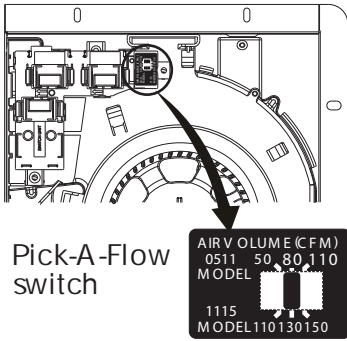

Pick-A-Flow Feature

All the WhisperGreen Select base models of fans come with Pick-A-Flow speed options. The Pick-A-Flow switch on the face of all WhisperGreen Select fans allows the option to choose 50 – 80 – 110 CFM for the FV-0511VKL2, FV-0511VKSL2 or 110 – 130 – 150 CFM for the FV-1115VKL2. These fans can run continuously or intermittently, depending upon the needs of the owner.

| Air volume type (CFM) | | | | Factory setting |
|-----------------------|-----|-----|-----|-----------------|
| FV-0511VKSL2 | 50 | 80 | 110 | 80 CFM |
| FV-0511VKL2 | | | | |
| FV-1115VKL2 | 110 | 130 | 150 | 130 CFM |

INDICATION (PLUG 'N PLAY FUNCTION DEVICES)

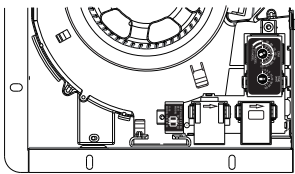

Note that there is ONLY ONE Plug 'N Play slot to insert the Multi-Speed module within the base model fan. There are TWO interchangeable Plug 'N Play slots to insert the Condensation Sensor module, Motion Sensor module within the base model fan.

PLUG 'N PLAY Modular Component Accessories

Sold Separately, Not Included With Base Model Fan

- FV-VS15VK1 Multi-Speed module** allows the fan to run continuously at lower speeds to maintain ventilation standards to meet Indoor Air Quality and then boosts up to high speed to meet intermittent needs for 'Spot' or 'Point Source' exhaust needs. The FV-VS15VK1 Modular Component will operate for both the FV-0511VKL2 and the FV-1115VKL2 matching the appropriate Multi-Speed setting shown below. The FV-0511VKSL2 comes with the FV-VS15VK1 Multi-Speed module. It is not necessary to purchase this component. Note the options on the face of the FV-VS15VK1 Multi-Speed module to choose appropriate levels of airflow (CFM) and time delay before returning back to low speed (TIME). Choosing the Pick-A-Flow setting automatically adjusts the Multi-Speed setting accordingly. As an example, if the Pick-A-Flow Multi-speed setting is 80 CFM, the Multi-Speed settings adjust automatically to be 0, 30, 40, 50, 60 or 70CFM at the lower speeds. The fan will 'boost' to the 80 CFM speed as the high speed setting. Selecting a particular TIME option will cause the fan to run for the selected amount of time before returning to the lower speed setting chosen on the CFM dial.

| Pick-A-Flow (CFM) | Multi-Speed Air volume (CFM) | | | | | | | | | |
|--|------------------------------|-----|----|----|----|----|----|-----|-----|-----|
| FV-0511VKSL2, FV-0511VKL2 (plug-in FV-VS15VK1) | 50 | 0 | 30 | 40 | 40 | 40 | 40 | 40 | 40 | 40 |
| | 80 | 0 | 30 | 40 | 50 | 60 | 70 | 70 | 70 | 70 |
| | 110 | 0 | 30 | 40 | 50 | 60 | 70 | 80 | 90 | 100 |
| FV-1115VKL2 (plug-in FV-VS15VK1) | 110 | 0 | 50 | 60 | 70 | 80 | 90 | 100 | 100 | 100 |
| | 130 | 0 | 50 | 60 | 70 | 80 | 90 | 100 | 110 | 110 |
| | 150 | 0 | 50 | 60 | 70 | 80 | 90 | 100 | 110 | 120 |
| Delay Time (min) | 0 | 0.5 | 5 | 10 | 20 | 30 | 45 | 60 | | |

Factory setting: 20 minutes.

Delay Time position "0" : Manual wall switch control is 0 minute; without manual wall switch control is 0.5 minute.

- FV-CSVK1 Condensation Sensor module** turns the base fan on or boosts to higher speed when humidity is detected when used in combination with the FV-VS15VK1. The Condensation Sensor works based on calculations from the Psychrometric Chart, or combination of Relative Humidity (RH) and Temperature. This allows the fan to anticipate the formation of condensation and automatically turn on when needed to expel humid air. The Condensation Sensor is pre-set to run for 20 minutes; it will then check the RH and Temperature to detect if the fan needs to run for another 20 minutes cycle.

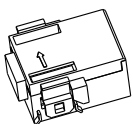
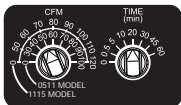

INDICATION (PLUG 'N PLAY FUNCTION DEVICES) CONTINUED

Humidity selector range from around 30% to 80%.

Factory setting is around 50%.

Timer preset selector positions

| | | | | | | | | | | |
|-------------|---|-----|---|---|---|---|----|----|----|----|
| Timer [min] | ▶ | 0.5 | 1 | 2 | 3 | 5 | 10 | 20 | 30 | 60 |
|-------------|---|-----|---|---|---|---|----|----|----|----|

Factory setting : 20 minutes.

Position "▶" : For factory use

- 1. The product will run when environment humidity rise rapidly but not reach to the humidity setting, and stop after delay preset time.
- 2. Humidity setting selector is stepless change between 30 %RH ~ 80 %RH.
- 3. The humidity detected by sensor may differ from the value on your hygrometer.
- 4. The product may turn on and off cause by the unstable environment humidity, you can improve it by adjusting the Humidity setting selector.

PLUG 'N PLAY Modular Component Accessories

Sold Separately, Not Included With Base Model Fan

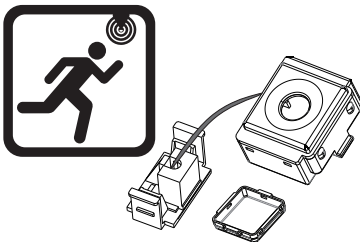

- FV-MSVK1 Motion Sensor module turns the base fan on or boosts to higher speed when motion is detected when using in combination with the FV-VS15VK1. The Motion Sensor is pre-set to run for 20 minutes; it will then re-check for movement; if detected the fan will run for another 20 minutes cycle. The Motion Sensor detects within the range shown below.

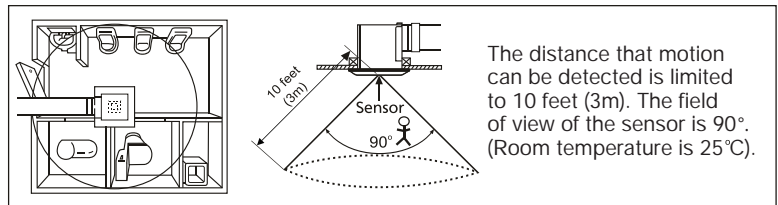

The distance that motion can be detected is limited to 10 feet (3m). The field of view of the sensor is 90°. (Room temperature is 25°C).

PLUG 'N PLAY Modular Components used in Combinations

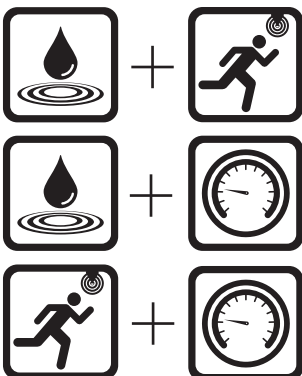

PLUG 'N PLAY Modular Component Accessories

Sold Separately, Not Included With Base Model Fan

FV-CSVK1 + FV-MSVK1

Turns the fan on for 20 minutes when either motion or excess humidity is detected.

FV-CSVK1 + FV-VS15VK1

Cycles the fan to high speed from low speed for the amount of time selected on the Control Dial based upon detection of excess humidity.

FV-MSVK1 + FV-VS15VK1

Cycles the fan to high speed from low speed for the amount of time selected on the Control Dial based upon motion within the room.

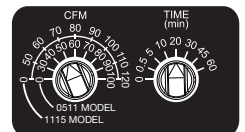
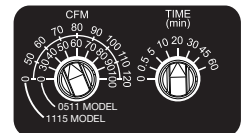

| | | | | | |
|--|--------------|--------------|---|--|---------|
| Module FV-MSVK1, FV-CSVK1 (Not included) | Human active | INSIDE | | | OUTSIDE |
| | Fan active | At low speed | When motion or excess humidity is detected, fan runs at high speed. | Remains running at high speed until the delay time has passed. | |

| Motion | Fan operation | Time delay operation |
|-----------------------|------------------|---|
| FV-CSVK1 only | Fan ON/OFF | 20 minutes time delay |
| FV-MSVK1 only | Fan ON/OFF | 20 minutes time delay |
| FV-CSVK1 + FV-VS15VK1 | Fan Hi/Low speed | Depend on FV-VS15VK1 Time delay setting |
| FV-MSVK1 + FV-VS15VK1 | Fan Hi/Low speed | Depend on FV-VS15VK1 Time delay setting |

INSTALLATION (PLUG 'N PLAY FUNCTION DEVICES)

You can purchase the specified Plug 'N Play devices that are explained on page 6-7 and install them in positions ①, ② and ③. Position ① can only be used with Multi-Speed module (model FV-0511VKSL2 already have this control installed), position ② and ③ can be used for any of the other optional control modules.

1. Remove the connector cover from position ①, ② or ③.
2. Plug in the specified devices to Base PCB box and fix to the slot, till hear the sound installed in place.

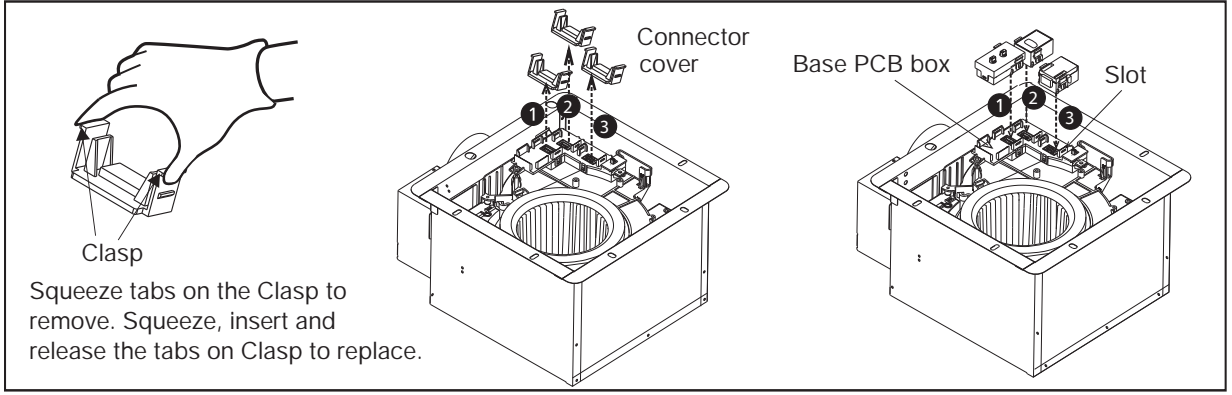

INSTALLATION (NEW CONSTRUCTION)

The fan position between joists from 16" to 24" on center can be adjusted flexibly.

CAUTION

! Please wear gloves during the installation work as follow.

1. Disconnect plug connector from receptacle and remove adaptor from fan body by removing the machine screw (M4X8) before installation. (Fig.1)

IMPORTANT:

Remove the tape from damper and adaptor before installation. As shown below:

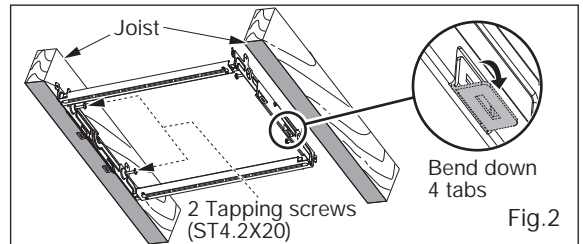
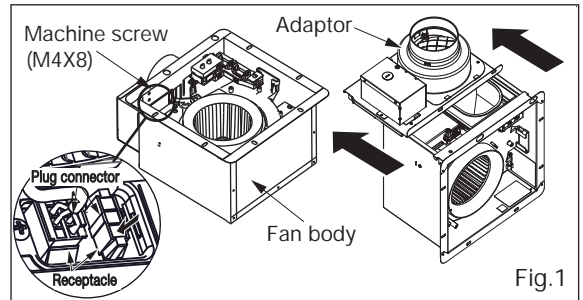
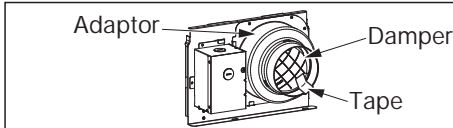

2. Bend down 4 tabs for positioning, install the Flex-Z Fast™ bracket to joists by drilling 2 tapping screws which have been fixed on it. (Fig.2)
3. Adjust the length of Flex-Z Fast™ bracket as the spacing between joists, and install to joists by drilling the other 2 tapping screws which have been fixed on it. (Fig.3)

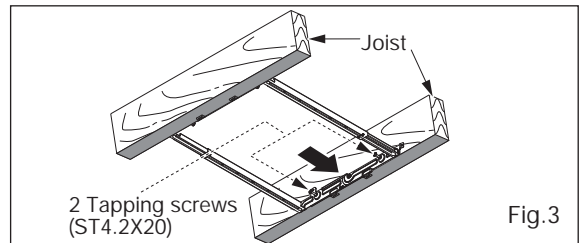

4. Remove junction box cover and secure conduit or stress relief to junction box knock-out hole. (Fig.4)
5. Install a circular duct and secure it with clamps, or ties and seal it with mastic or approved foil tape. A 4 or 6 inch circular duct is needed to connect to relevant part of adaptor. (Fig.4)
6. Install the adaptor to Flex-Z Fast™ bracket by using 2 self-drilling screws. (Fig.4)

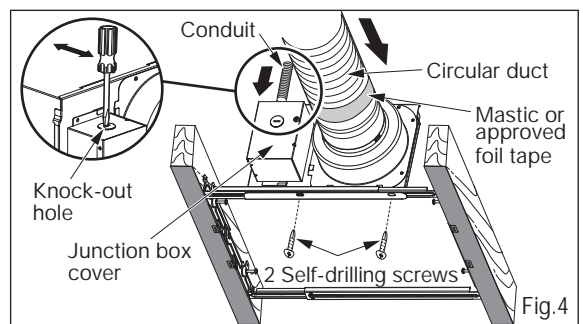

INSTALLATION (NEW CONSTRUCTION) CONTINUED

7. Refer to wiring diagram on page 5. Follow all the local electrical safety codes as well as the National Electrical Code (NEC). Using UL approved wire nuts, connect house power wires to ventilating fan wires. (Fig.5)

CAUTION

- Mount junction box cover carefully so that lead wires are not pinched.

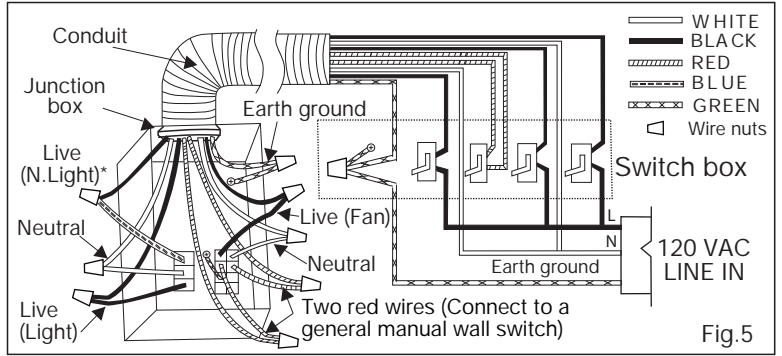

* Night Light

8. Insert fan body and slide into adaptor assy with some strength, until the flange overlaps the Flex-ZFast™ bracket. Secure the fan body to Flex-ZFast™ bracket by using 2 self-drilling screws, plug connector to receptacle and secure the fan body to adaptor by using machine screw (M4X8). (Fig.6)

CAUTION

- Secure machine screw (M4X8) to the suitable hole and not touch the Flex-Z Fast™ bracket. Please fix the screw carefully to avoid screw slip teeth.

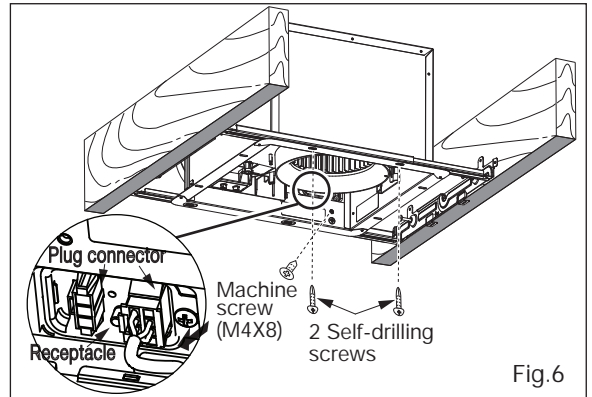

Fig.6

9. Finish ceiling work. Ceiling hole should be aligned with the inside edge of the flange. (Fig.7)

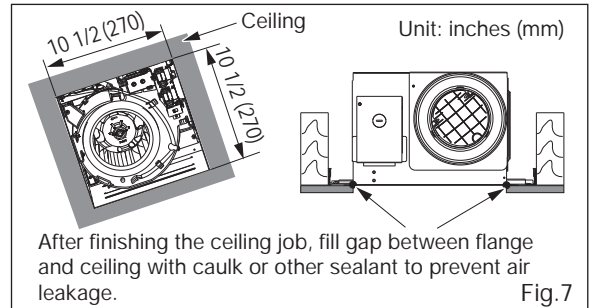

Fig.7

10. Insert the grille mounting spring on the wiring side into the slot and insert the plug connector into the housing of the lighting unit. (Fig.8)

CAUTION

- Before turn on the light, make sure the connector at the correct position. If not, the lighting can't work.
- The claw of connector must latch the rib completely.

IMPORTANT:

Replace the sensor cover before the installation (only for plug-in Motion sensor module FV-MSVK1). (Fig.9)

- Keep on pressing the clasps when removing the ornamental cover.
- Insert the sensor cover (attachment for FV-MSVK1) into slot.

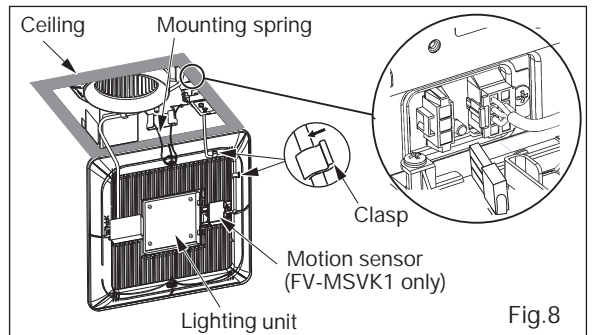

Fig.8

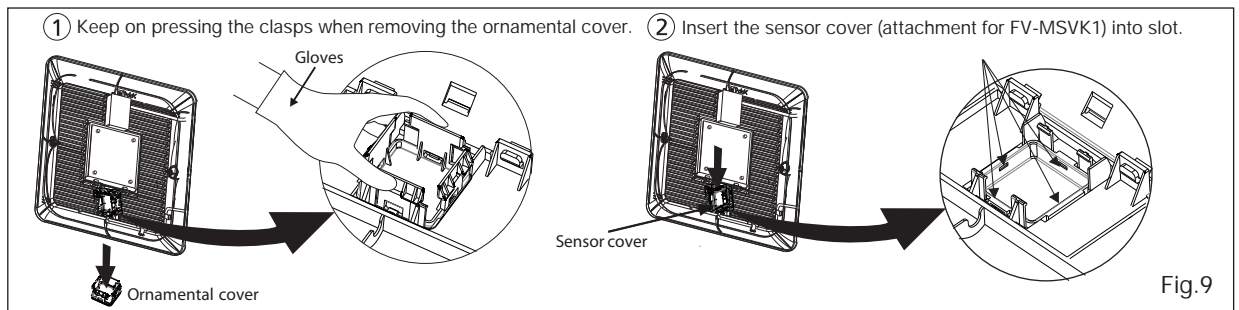
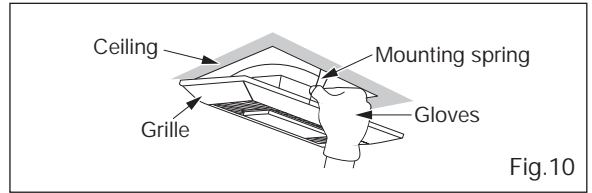

Fig.9

INSTALLATION (NEW CONSTRUCTION) CONTINUED

11. Adjust Pick-A-Flow switch.(Refer to indication on FEATURE.)
12. Insert the other mounting spring into the slot as shown and mount grille to fan body. (Fig.10)



CAUTION

! Mount grille carefully so that lead wire is not pinched.

! **Attention:** when the switch is at the "ON" position, wait 8 – 10 seconds for the Fan to start. This is a normal working condition.

INSTALLATION (RETROFIT)

WARNING

! Disconnect power source before working on unit.

1. Remove the existing fan and cut ceiling opening. Secure the Flex-Z Fast™ bracket to joists by drilling 4 tapping screws (ST4.2x20) which have been fixed on it. Existing ductwork and wiring left in place. (Fig.11)
2. Follow the step 1 , 4 , 5 , 7 on INSTALLATION (NEW CONSTRUCTION). (Before connect the circular duct to the adaptor, should pull down the circular duct from the ceiling)
3. Install the adaptor to Flex-Z Fast™ bracket by using 2 self-drilling screws. (Fig.12)
4. Secure the fan body to Flex-Z Fast™ bracket by using 2 self-drilling screws, plug connector to receptacle and secure the fan body to adaptor by using machine screw (M4X8). (Fig.13)

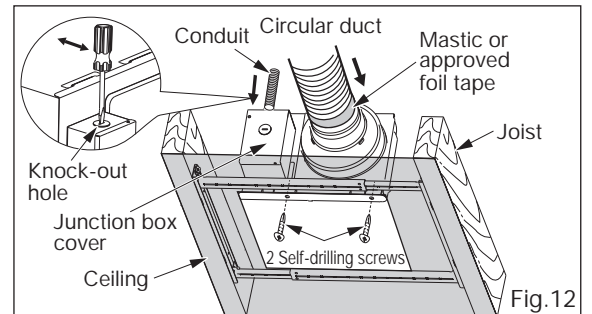
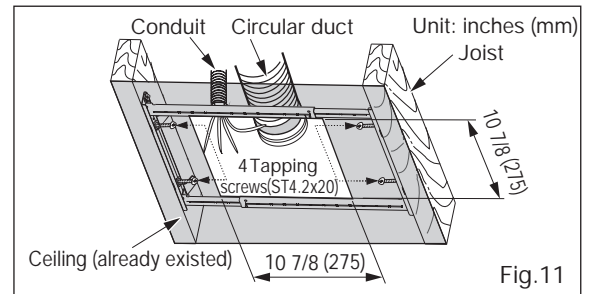

CAUTION

! Secure machine screw (M4X8) to the suitable hole and not touch the Flex-Z Fast™ bracket. Please fix the screw carefully to avoid screw slip teeth.

5. Follow the step 10 to 12 on INSTALLATION (NEW CONSTRUCTION)

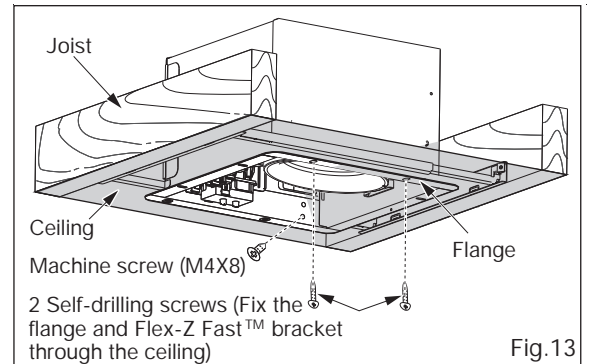

MAINTENANCE (CLEANING)

! WARNING

! Disconnect power source before working on unit.

! CAUTION

- ! Routine maintenance must be done every year. Please wear gloves during the cleaning work.
- ⊘ Never use gasoline, benzene, thinner or any other such chemicals for cleaning the ventilating fan.
- ⊘ Do not immerse motor in water when cleaning. Do not soak resin parts in water over 140°F (60°C).
- ⊘ Do not use cleaning sprays, solvents, or water on or near the sensors.

1. Remove grille by pulling down one mounting spring (Fig.14), then pull down the other. (Pull down the mounting spring that without lead wire passed side, shown in Fig.15) (Squeeze mounting spring and pull down carefully)
2. Clean grille. (Don't put into hot water. Use non-abrasive kitchen detergent, wipe dry with clean cloth) (Fig.16)
3. The grille should be dry after cleaning.
4. Remove dust and dirt from fan body using a vacuum cleaner. (Fig.17)
5. Using a cloth dampened with kitchen detergent, remove any dirt from fan body. Wipe dry with clean cloth. (Fig.18)
6. Reinstall grille.

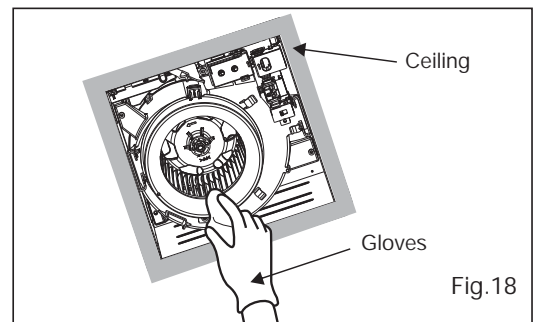
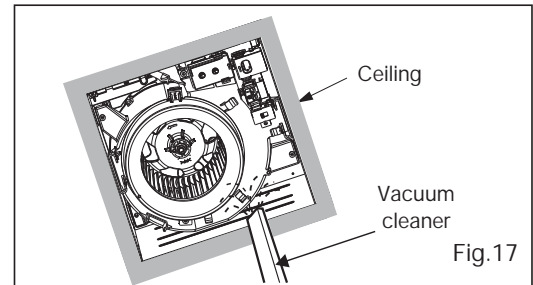
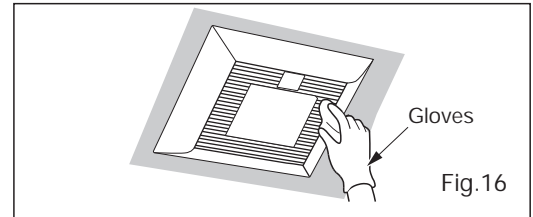
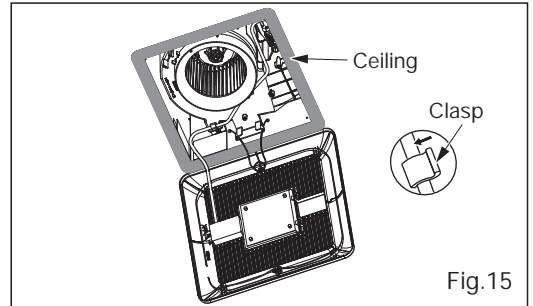
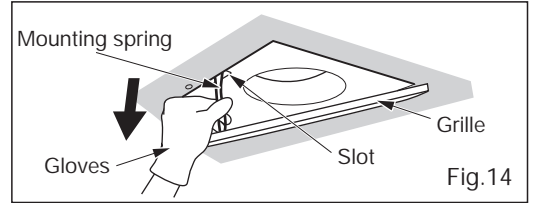

PRACTICAL GUIDE TO INSTALLATION

Properly insulate the area around the fan to minimize building heat loss and gain. (Fig.19) Loose fill or batt insulation can be placed directly over the fan housing in the attic.

Our fans does not create excessive heat that is a common problem with recessed light fixtures or some competitor's fan/light combination. Our efficient, cool-running motors do not create enough ambient heat to be subjected to these limitations.

The ducting from this fan to the outside of the building has a strong effect on the air flow, noise and energy use of the fan. Use the shortest, straightest duct routing possible for best performance, and avoid installing the fan with smaller ducts than recommended. Insulation around the ducts can reduce energy loss and inhibit mold growth. Fans installed with existing ducts may not achieve their rated air flow.

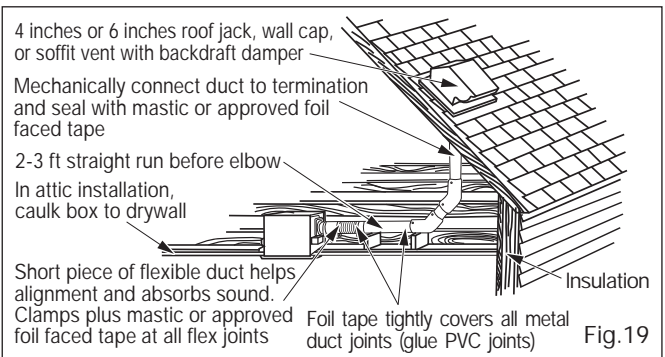

Fig.19

SPECIFICATIONS

■ Specifications for Base Model fans

| Model No. | Air direction | Voltage (V) | Frequency (Hz) | Duct diameter (inches) | Air volume at 0.1" WG (CFM) | Noise (sones) | Speed (rpm) | Power (W) | | Weight lb. (kg) |
|-----------------------------|---------------|-------------|----------------|------------------------|-----------------------------|---------------|-------------|-----------|---------------|-----------------|
| | | | | | | | | Fan | Lighting unit | |
| FV-0511VKSL2 FV-0511VKL2 | Exhaust | 120 | 60 | 4 or 6 | 110 | 0.4 | 958 | 10.5 | 10 | 10.6(4.8) |
| | | | | | 80 | <0.3 | 811 | 5.3 | | |
| | | | | | 50 | <0.3 | 730 | 3.2 | | |
| FV-1115VKL2 | Exhaust | 120 | 60 | 6 | 150 | 0.5 | 722 | 14.9 | 10 | 10.7(4.9) |
| | | | | | 130 | <0.3 | 682 | 10.4 | | |
| | | | | | 110 | <0.3 | 648 | 7.5 | | |

HVI Certified performance based on HVI Procedures 915, 916, and 920.

■ Specifications for Multi Speed fans

| Model No. | Air direction | Voltage (V) | Frequency (Hz) | Duct diameter (inches) | Air volume at 0.1" WG (CFM) | Noise (sones) | Speed (rpm) | Power (W) | | Weight lb. (kg) |
|---|---------------|-------------|----------------|------------------------|-----------------------------|---------------|-------------|-----------|---------------|-----------------|
| | | | | | | | | Fan | Lighting unit | |
| FV-0511VKSL2, FV-0511VKL2 (Plug-in FV-VS15VK1) | Exhaust | 120 | 60 | 4 or 6 | 100 | <0.3 | 908 | 8.2 | 10 | 10.6(4.8) |
| | | | | | 90 | <0.3 | 868 | 6.7 | | |
| | | | | | 80 | <0.3 | 811 | 5.3 | | |
| | | | | | 70 | <0.3 | 785 | 4.6 | | |
| | | | | | 60 | <0.3 | 750 | 3.7 | | |
| | | | | | 50 | <0.3 | 730 | 3.2 | | |
| | | | | | 40 | <0.3 | 710 | 2.7 | | |
| | | | | | 30 | <0.3 | 720 | 2.5 | | |
| FV-1115VKL2 (Plug-in FV-VS15VK1) | Exhaust | 120 | 60 | 6 | 120 | <0.3 | 670 | 8.4 | 10 | 10.7(4.9) |
| | | | | | 110 | <0.3 | 648 | 7.5 | | |
| | | | | | 100 | <0.3 | 636 | 6.0 | | |
| | | | | | 90 | <0.3 | 627 | 5.0 | | |
| | | | | | 80 | <0.3 | 625 | 4.6 | | |
| | | | | | 70 | <0.3 | 613 | 3.8 | | |
| | | | | | 60 | <0.3 | 610 | 3.3 | | |
| | | | | | 50 | <0.3 | 621 | 3.1 | | |
| | | | | | 0 | — | — | 0.5 (*) | | |

Reference performance based on HVI Procedures 915, 916, and 920. [(*) Standby wattage.]

PRODUCT SERVICE

Warning Concerning Removal of Covers. The unit should be serviced by qualified technicians only. Your product is designed and manufactured to ensure a minimum of maintenance. Should your unit require service or parts, call Panasonic Call Center at 1-866-292-7299 (USA) or 1-800-669-5165 (Canada).

Panasonic Corporation of North America
Two Riverfront Plaza, Newark, NJ 07102
www.panasonic.com

Panasonic Canada Inc.
5770 Ambler Drive, Mississauga, Ontario L4W 2T3
www.panasonic.ca