



Incandescent

Glass Pendants

Pendants

Type _____
-09

P5003

Catalog No.	Finish		Lamping	Dimensions (Inches)		
	Brushed Nickel			A	B	C
P5003	-09		1 (m) 75w	12-1/4	7-1/8	73

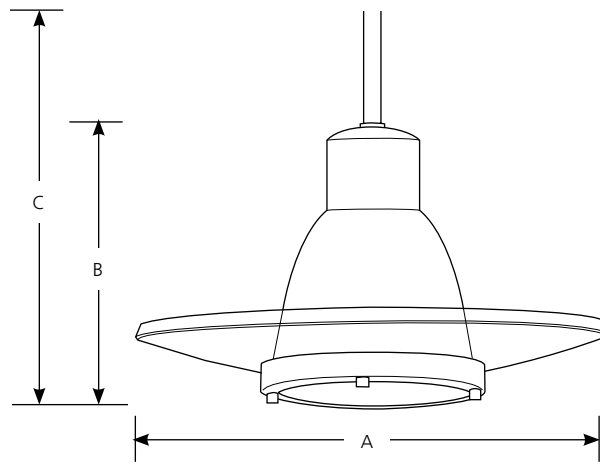

Specifications:

General

- Clear glass glass ring (12-1/4" dia.) with etched glass diffuser
- Plated Brushed Nickel (-09) finish
- Steel construction
- 6 links of 9 gauge chain supplied.
- Two 6", one 12", two 15" lengths of stem included

Electrical

- Medium base porcelain socket
- 10 feet of wire supplied
- Pre-wired

Labeling

- UL-CUL listed

Mounting

- Ceiling stem mounted with 6 links of chain mount
- Canopy covers a standard 4" hexagonal recessed outlet box: 5-1/4" dia.
- Mounting strap for outlet box included

Progress Lighting
701 Millennium Blvd.
Greenville, South Carolina
29607

www.progresslighting.com

Rev. 04/13