



Incandescent

Wall Bracket

Outdoor

Wall Mount

Type _____

-09 -10 -11 -30 -31
 P5602

Catalog No.	Finish						Lamping	Dimensions (Inches)			
	Brushed Nickel	Polished Brass	Weathered Brass	Antique				A	B	C	D
P5602	-09	-10	-11	Bronze -20	White -30	Black -31	1-75w A19	4-1/2	5-1/2	7-1/4	2-1/4

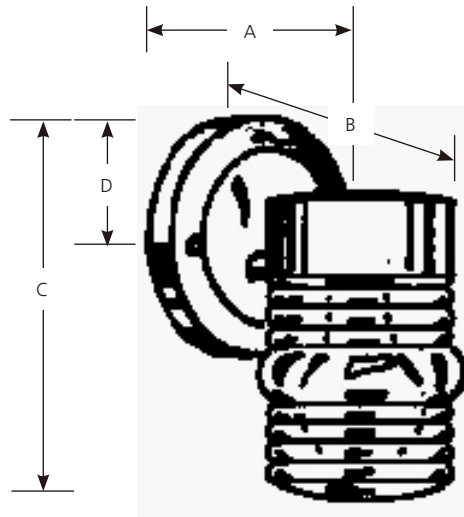

Specifications:

General

- Wall bracket
- Clear marine type glass
- Brushed Nickel, Polished Brass, Weathered Brass, Antique Bronze, White or Black finishes
- Powder coated clear finish over plating, or painted finish on steel housing
- Lamp replacement - Glass removed with thumb screw

Electrical

- Medium base ceramic socket with nickel plated screw shell

Labeling

- UL-CUL wet location listed

Mounting

- Wall mounted
- Covers standard junction box
- Mounting strap for outlet box and cap nuts provided
- Back plate - 4-1/2" dia.

Progress Lighting
 701 Millennium Blvd.
 Greenville, South Carolina
 29607

www.progresslighting.com

Rev. 6/11