

Installation & Operation Manual

NFC Condensing Combi-Boilers

Model | NFC-175
NFC-200



Keep this manual near this boiler for future reference whenever maintenance or service is required.

* The wetted surface of this product contacted by consumable water contains less than one quarter of one percent (0.25%) of lead by weight.



WARNING

If the information in these instructions is not followed exactly, a fire or explosion may result, causing property damage, personal injury, or death.

Do not store or use gasoline or other flammable vapors and liquids in the vicinity of this or any other appliance.

WHAT TO DO IF YOU SMELL GAS

- Do not try to light any appliance.
- Do not touch any electrical switch; do not use any phone in your building.
- Immediately call your gas supplier from a neighbor's phone. Follow the gas supplier's instructions.
- If you cannot reach your gas supplier, call the fire department.

Installation and service must be performed by a qualified installer, service agency or the gas supplier.

The installation must conform with local codes or, in the absence of local codes, the National Fuel Gas Code, ANSI Z223.1/NFPA 54 and/or CSA B149.1, Natural Gas and Propane Installation Code.

Requirements for the State of Massachusetts

NOTICE BEFORE INSTALLATION

This appliance must be installed by a licensed plumber or gas fitter in accordance with the Massachusetts Plumbing and Fuel Gas Code 248 CMR Sections 4.00 and 5.00.

IMPORTANT: In the State of Massachusetts (248 CMR 4.00 & 5.00)

For all side wall horizontally vented gas fueled equipment installed in every dwelling, building or structure used in whole or in part for residential purposes, including those owned or operated by the Commonwealth and where the side wall exhaust vent termination is less than seven (7) feet above finished grade in the area of the venting, including but not limited to decks and porches, the following requirements shall be satisfied:

1. **INSTALLATION OF CARBON MONOXIDE DETECTORS.** No installation or replacement of a vented gas appliance shall be permitted unless a battery powered or electrically hard wired carbon monoxide detector is present on the same floor as the appliance or on the next adjacent floor when the appliance is located in a crawl space unless the appliance is located in a detached, uninhabitable garage. For all residential dwellings, a carbon monoxide detector must also be present on each habitable level of the dwelling. These requirements shall not be deemed to waive any additional requirements imposed by M.G.L. c. 148 §26F1/2.
2. **APPROVED CARBON MONOXIDE DETECTORS.** Each carbon monoxide detector as required in accordance with the above provisions shall comply with NFPA 720 and be ANSI/UL 2034 listed and IAS certified.
3. **SIGNAGE.** Whenever any through-the-wall vent is installed less than seven feet above the finished grade, a metal or plastic identification plate shall be permanently mounted to the exterior of the building at a minimum height of eight feet above grade directly in line with the exhaust vent terminal. The sign shall read, in print size no less than 0.5 inches in size, **"GAS VENT DIRECTLY BELOW. KEEP CLEAR OF ALL OBSTRUCTIONS"**.
4. **INSPECTION.** The state or local gas inspector of the side wall horizontally vented gas fueled equipment shall not approve the installation unless, upon inspection, the inspector observes carbon monoxide detectors and signage installed in accordance with the provisions of 248 CMR 5.09 and 5.12.

Contents

| | | | |
|--|-----------|---|------------|
| Safety Information | 4 | 7. Connecting the Power Supply | 62 |
| 1. About the Boiler | 7 | 8. Installing a Cascade System | 63 |
| 1.1 Included Items | 7 | 8.1 Connecting Water Supplies | 63 |
| 1.2 Accessories | 7 | 8.2 Cascade System - Recirculation System Application Example | 65 |
| 1.3 Specifications | 8 | 8.3 Connecting the Communication Cables | 67 |
| 1.4 Components | 11 | 9. Installing a Common Vent System | 69 |
| 1.5 Dimensions | 13 | 9.1 About the Common Vent System | 69 |
| 1.6 Rating Plate | 14 | 9.2 Navien Backflow Damper (Back-draft Damper) | 74 |
| 2. Installing the Boiler | 15 | 9.3 Starting the Common Vent System | 75 |
| 2.1 Removing the Wood Pallet from the boiler | 15 | 9.4 Connecting and Terminating the Vent Pipe | 77 |
| 2.2 Choosing an Installation Location | 16 | 9.5 Setting Up the Common Vent System | 78 |
| 2.3 Mounting the Boiler to the Wall | 18 | 9.6 Common Vent Termination Clearances | 78 |
| 3. Installing the System Piping | 19 | 9.7 Installing a Condensate Drain | 80 |
| 3.1 Installing a Space Heating System | 19 | 9.8 Exhaust Vent Termination Clearances (For Direct Vent) | 81 |
| 3.2 Installing a Domestic Hot Water (DHW) System | 23 | 9.9 Maintenance | 82 |
| 3.3 Connecting the Condensate Drain | 25 | 10. Installation Checklist | 83 |
| 3.4 Filling the System | 28 | 11. Operating the Boiler | 86 |
| 3.5 Testing the Water System | 29 | 11.1 Turning the Boiler On or Off | 86 |
| 3.6 Considerations for System Applications | 30 | 11.2 Adjusting the Temperature | 86 |
| 3.7 Examples of Electrical Connections | 38 | 11.3 Accessing Basic Menu Items | 88 |
| 4. Connecting the Gas Supply | 47 | 11.4 Accessing Advanced Menu Items | 94 |
| 4.1 Gas Pipe Sizing Tables | 49 | 11.5 Understanding Error Codes | 101 |
| 4.2 Measuring the Inlet Gas Pressure | 50 | 12. Appendixes | 103 |
| 5. Venting the Boiler | 52 | 12.1 Gas & High Altitude Conversion | 103 |
| 5.1 Selecting a Vent Type | 53 | 12.2 Wiring Diagram | 110 |
| 5.2 Selecting Vent Pipe Materials | 56 | 12.3 Ladder Diagram | 111 |
| 5.3 Measuring Vent Length | 57 | 12.4 Outdoor Temperature Sensor | 112 |
| 5.4 Terminating the Vent | 57 | 12.5 Outdoor Reset Control | 113 |
| 6. Setting the DIP Switches | 60 | 12.6 Component Assembly Diagrams and Parts Lists | 114 |
| 6.1 DIP Switch 1 (6 switch unit) | 60 | | |
| 6.2 Dip Switch 2 (8 switch unit) | 60 | | |

Safety Information

The following safety symbols are used in this manual. Read and follow all safety instructions in this manual precisely to avoid unsafe operating conditions, fire, explosion, property damage, personal injury, or death.

DANGER

Indicates an imminently hazardous situation which, if not avoided, could result in severe injury or death.

WARNING

Indicates a potentially hazardous situation which, if not avoided, could result in injury or death.

CAUTION

Indicates a potentially hazardous situation that, if not avoided, could result in property damage.

DANGER

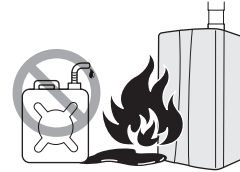

If you smell gas:

- Do not try to light any appliance.
- Do not touch any electrical switches or use landline phones.
- From a neighbor's phone, call your gas provider and follow their instructions.
- If you cannot reach your gas provider, call the fire department.
- Do not return to your home until authorized by your gas supplier or the fire department.

Do not use or store flammable products, such as gasoline, solvents, or adhesives in the same room or area as the boiler.

- The boiler has a main burner flame that can turn on at any time and can ignite flammable vapors. Vapors from flammable liquids can explode and catch fire, causing death or severe burns.
- Vapors cannot be seen and are heavier than air. They can travel long distances along the ground and can be carried from other rooms to the boiler's main burner flame by air current.
- Keep all flammable products far away from the boiler and store them in approved containers. Keep the containers closed tightly and out of the reach of children and pets.

 **WARNING**

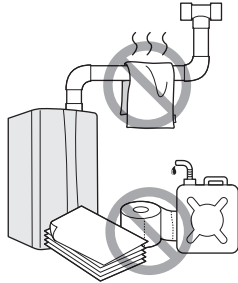

- **Do not store or use gasoline or other flammable liquids near this boiler.**
Doing so may result in fire or explosion.
- **Do not place combustibles, such as newspapers or laundry, near the boiler or venting system.**
Doing so may result in a fire.
- **Do not place or use hair sprays, spray paints, or any other compressed gases near the boiler or venting system, including the vent termination.**
Doing so may result in fire or explosion.
- **Do not operate the boiler with the front cover opened.**
Doing so may result in fire or carbon monoxide (CO) poisoning, which may result in property damage, personal injury, or death.
- **Do not operate this boiler without proper venting.**
Doing so may result in fire or carbon monoxide (CO) poisoning, which may result in property damage, personal injury, or death.
- **Do not touch the power cord or internal components of the boiler with wet hands.**
Doing so may result in electric shock.

 **CAUTION**

- **Do not turn on the boiler unless the water and gas supplies are fully opened.**
Doing so may damage the boiler.
- **Do not use this boiler for anything other than its intended purpose, as described in this manual.**
- **Do not remove the front cover unless the power to the boiler is turned off or disconnected.**
Failure to do so may result in electric shock.
- **When servicing the controls, label all wires prior to disconnecting them.**
Failure to do so may result in wiring errors, which can lead to improper or dangerous operation. Verify proper operation after servicing.
- **Do not use unapproved replacement or accessory parts.**
Doing so may result in improper or dangerous operation and will void the manufacturer's warranty.
- **Do not place anything in or around the vent terminals, such as a clothes line, that could obstruct the air flow in or out of the boiler.**
- **This boiler has been approved for use in the USA and Canada only.**
Using the boiler in any other country will void the manufacturer's warranty.

California law requires the following Prop 65 warning to be provided:

 **WARNING**

This product can expose you to chemicals including lead, lead compounds, and carbon bisulfide which are known to the State of California to cause cancer and birth defects or other reproductive harm. For more information, go to www.P65Warnings.ca.gov.

! DANGER



To prevent burns:

- Use the lowest operating temperature setting necessary to provide comfortably-hot water.
- If your household has children or elderly or disabled residents, consider using a lower temperature setting.
- Read all the instructions in this manual carefully before changing the temperature setting.
- Feel the water before using it on children, the elderly, or the disabled.
- If it is necessary to set the water temperature above 125°F (52°C), consider installing a thermostatically-controlled mixing valve or temperature-limiting valve. Contact a licensed plumber or your local plumbing authority for more information.

! DANGER









This boiler's DHW temperature is set to 120°F (49°C) at the factory for your safety and comfort. Increasing the temperature increases the risk of accidental scalding. Water temperatures at or above 125°F (52°C) can cause instant scalding, severe burns, or death. Before you decide to change the temperature setting, read the following charts carefully.



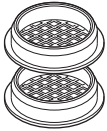
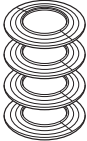

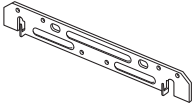
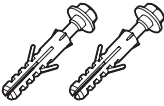
| Water Temperature | Time in which a young child can suffer a full thickness (3rd degree) burn |
|-------------------|---|
| 160°F (70°C) | Less than 1 second |
| 140°F (60°C) | 1 second |
| 130°F (55°C) | 10 seconds |
| 120°F (49°C) | 10 minutes |
| 100°F (37°C) | very low scald risk |

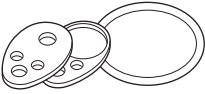
1. About the Boiler

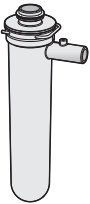
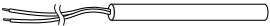
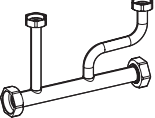
1.1 Included Items

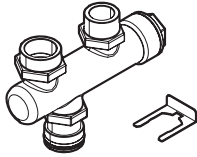
When you open the box, you will find the following items with the boiler. Check the box for each of the following items before installing the boiler.

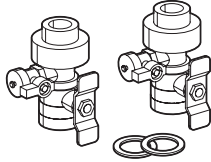

| | |
|---|---|
|  |  |
| Installation & Operation Manual, User's Information Manual | Quick Installation Manual |
|  |  |
| 2 in Vent Termination Caps (x2) | 2 in Wall Flanges (x4) |
|  |  |
| Air Vent | Wall Mounting Bracket |
|  |  |
| Tapping Screws & Anchors (x2) | Pressure Relief Valve, Heating |
|  |  |
| Conversion Kit | Outdoor Temperature Sensor and Cable |
|  |  |
| Air Vent Bushing (3/4in to 1/2in) | Condensate Trap |
|  |  |
| System Temperature Sensor | NFC-175/200 Manifold System (for single boilers) |

| | |
|--|---|
|  |  |
| PRV-Air Vent Adapter (including a clip) | NaviClean |
|  |  |
| Valve Kit | Union |

Note The Universal Temperature Sensor can be used as a System Temperature Sensor or a DHW Tank Sensor.

1.2 Accessories

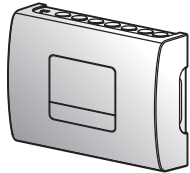
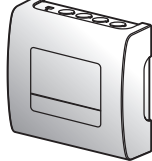
The following optional accessories are available for the boiler.

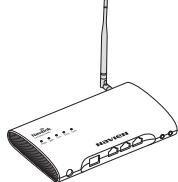
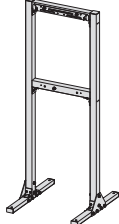
| | |
|--|---|
|  |  |
| Condensate Neutralizer Kit | Zone Controller (FMZ-40/60) |
|  |  |
| Zone Controller (FMZ-20/30) | Universal Temperature Sensor (with clip) |
|  |  |
| Navi-Link (Wi-Fi Control System) | Ready-Link Rack |

1.3 Specifications

The following tables list the specifications for the boiler. Additional specifications for water, gas, electricity, and vent connections are provided in the Installation section.

Space Heating Specifications

| Navien Condensing Boiler Space Heating Ratings | | | | |  | | | | Other Specifications | | |
|---|---------------------|-----|--|---|---|----------------|---|--------------|----------------------|--|--|
| Model Number ¹ | Heating Input (MBH) | | Heating Capacity ² (MBH) | Net AHRI Rating Water ³ (MBH) | AFUE ² (%) | Water Pressure | Water Connection Size (Supply, Return) | Water Volume | | | |
| | Min | Max | | | | | | | | | |
| NFC-175 | 18 | 175 | 161 | 140 | 95 | 12-80 psi | 1 in NPT | 4.5 gallons | | | |
| NFC-200 | 18 | 199 | 183 | 159 | 95 | | | | | | |

Note

1. Ratings are the same for natural gas models converted to propane use.
2. Based on U.S. Department of Energy (DOE) test procedures.
3. The net AHRI water ratings shown are based on a piping and pickup allowance of 1.15. Consult Navien before selecting a boiler for installations having unusual piping and pickup requirements, such as intermittent system operation, extensive piping system, etc.

Domestic Hot Water Specifications

| Item | | NFC-175 | NFC-200 |
|----------------------------------|-----|-------------------|---------------|
| Input Ratings | Min | 18,000 BTU/H | 18,000 BTU/H |
| | Max | 199,900 BTU/H | 199,900 BTU/H |
| Water Pressure | | 15-150 psi | |
| Minimum Flow Rate | | 0.5 GPM (1.9 L/m) | |
| Flow Rate 45°F (25°C) Temp. Rise | | 7.9 GPM | |
| DHW Supply Connection Size | | 3/4 in NPT | |
| Cold Water Input Connection Size | | 3/4 in NPT | |

NFC Internal Pump

The NFC boiler is equipped with an internal circulation pump. The following table provides detailed information on the pump used for the boiler and the performance curve.

| Item | Pump Model |
|--|---|
| NFC-175/200 Internal Recirculation Pump | Grundfos UPS 15-78 CIL2 (Part Number: 30021636A) |

NFC Flow Performance Curve

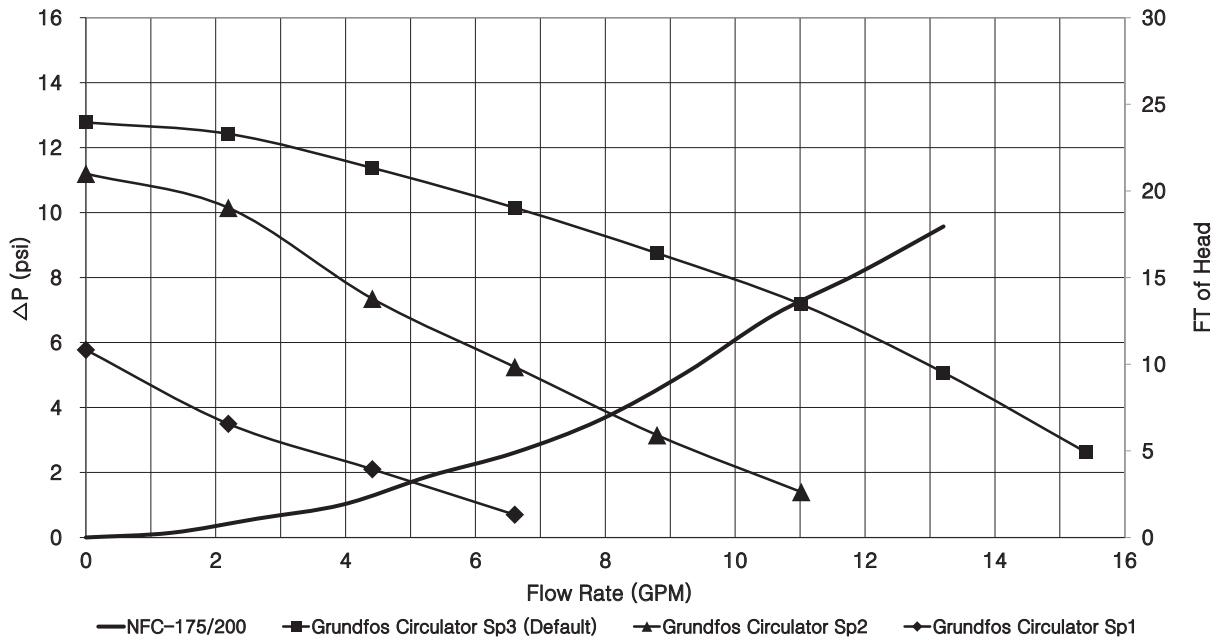

NFC DHW Pressure Drop Curve

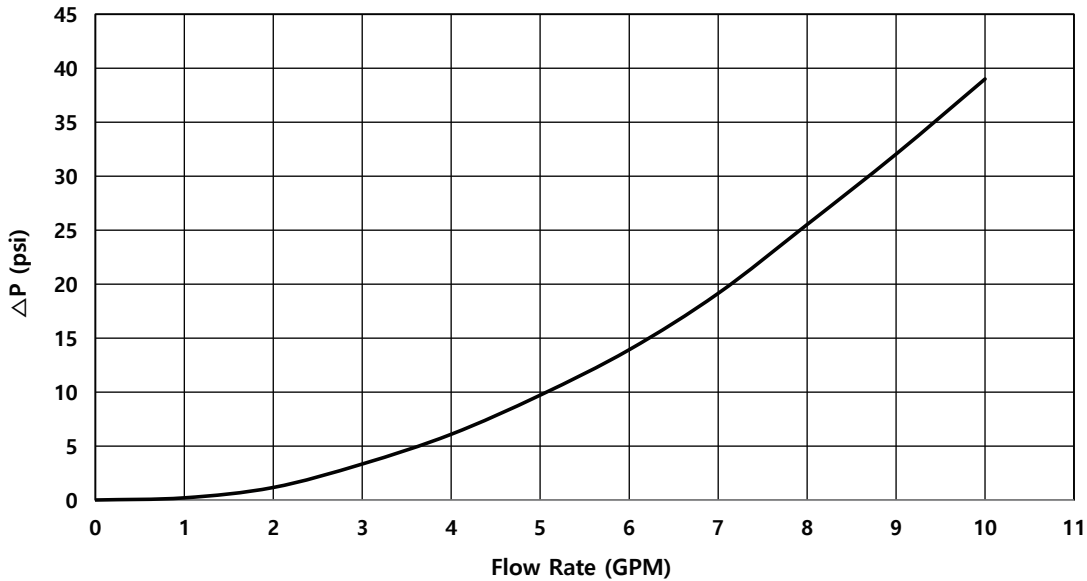

General Specifications

| Item | | NFC-175 | NFC-200 |
|---|---------------------------|--|----------------------|
| Dimensions | | 17.3 in (W) x 17.3 in (D) x 33.5 in (H) | |
| Boiler Weight | | 145 lb (66 kg) | |
| Boiler Weight with Water | | 183 lb (83 kg) | |
| Installation Type | | Indoor Wall-Hung | |
| Venting Type | | Forced Draft Direct Vent | |
| Ignition | | Electronic Ignition | |
| Natural Gas Supply Pressure (from source) | | 3.5 in–10.5 in WC | |
| Propane Gas Supply Pressure (from source) | | 8.0 in–13.5 in WC | |
| Natural Gas Manifold Pressure | | -0.05 to -0.47 in WC | -0.05 to -0.20 in WC |
| Propane Gas Manifold Pressure | | -0.10 to -0.45 in WC | -0.10 to -0.45 in WC |
| Flow Rate (DHW) | 35°F (19°C) Temp Rise | 10.4 GPM (39.5 L/m) | |
| | 45°F (25°C) Temp Rise | 7.9 GPM (30.0 L/m) | |
| | 67°F (37°C) Temp Rise | 5.4 GPM (20.3 L/m) | |
| Gas Connection Size | | ¾ in NPT | |
| Power Supply | Main Supply | 120V AC, 60Hz | |
| | Maximum Power Consumption | Less than 15 amperes | |
| Materials | Casing | Cold-rolled carbon steel | |
| | Heat Exchangers | Stainless Steel | |
| Venting | Exhaust | 2 in or 3 in PVC, CPVC, approved polypropylene* 2 in or 3 in Special Gas Vent Type BH (Class III, A/B/C) 2 in or 3 in Stainless Steel | |
| | Intake | 2 in or 3 in PVC, CPVC, polypropylene 2 in or 3 in Special Gas Vent Type BH (Class III, A/B/C) 2 in or 3 in Stainless Steel | |
| | Vent Clearance | 0 in to combustibles | |
| Safety Appliances | | Flame Rod, APS, Ignition Operation Detector Water Temperature High Limit Switch, Exhaust Temperature High Limit Sensor, Water Pressure Sensor | |

Temperature Setting Range

| Item | | Temperature Setting Range | Remarks |
|---------------|--------|---------------------------|---|
| Space Heating | Supply | 77–194°F (25–90°C) | Actual supply and return temperatures vary depending on the selected outdoor reset curve. |
| | Return | 68–158°F (20–70°C) | |
| DHW | | 86°F–140°F (30°C–60°C) | |

Note For more information about the space heating temperature setting range, refer to “11.3.3 Setting the Space Heating Operation” on page 86.

1.4 Components

The following diagram shows the key components of the boiler. Component assembly diagrams and particular parts lists are included in the Appendixes.

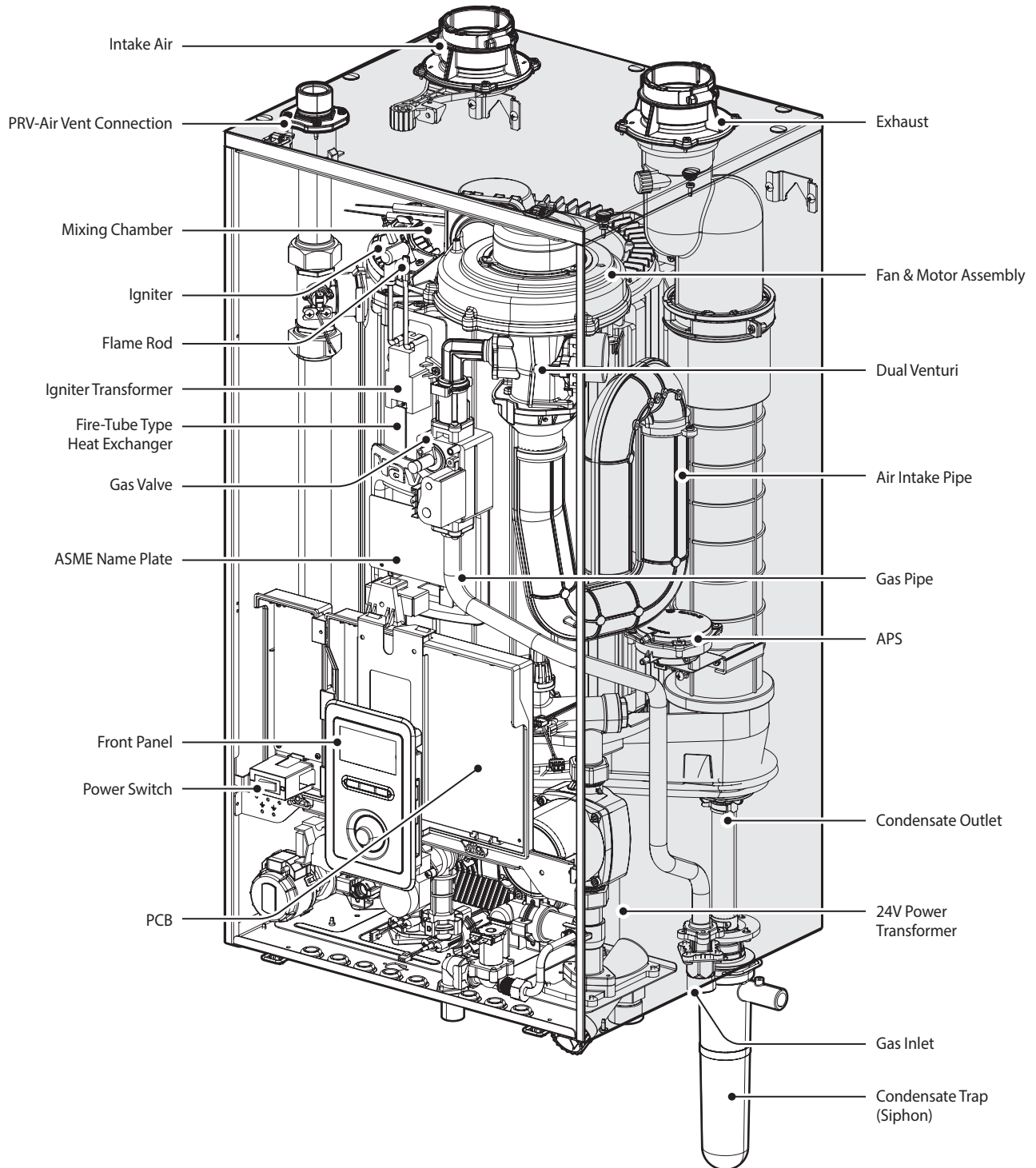

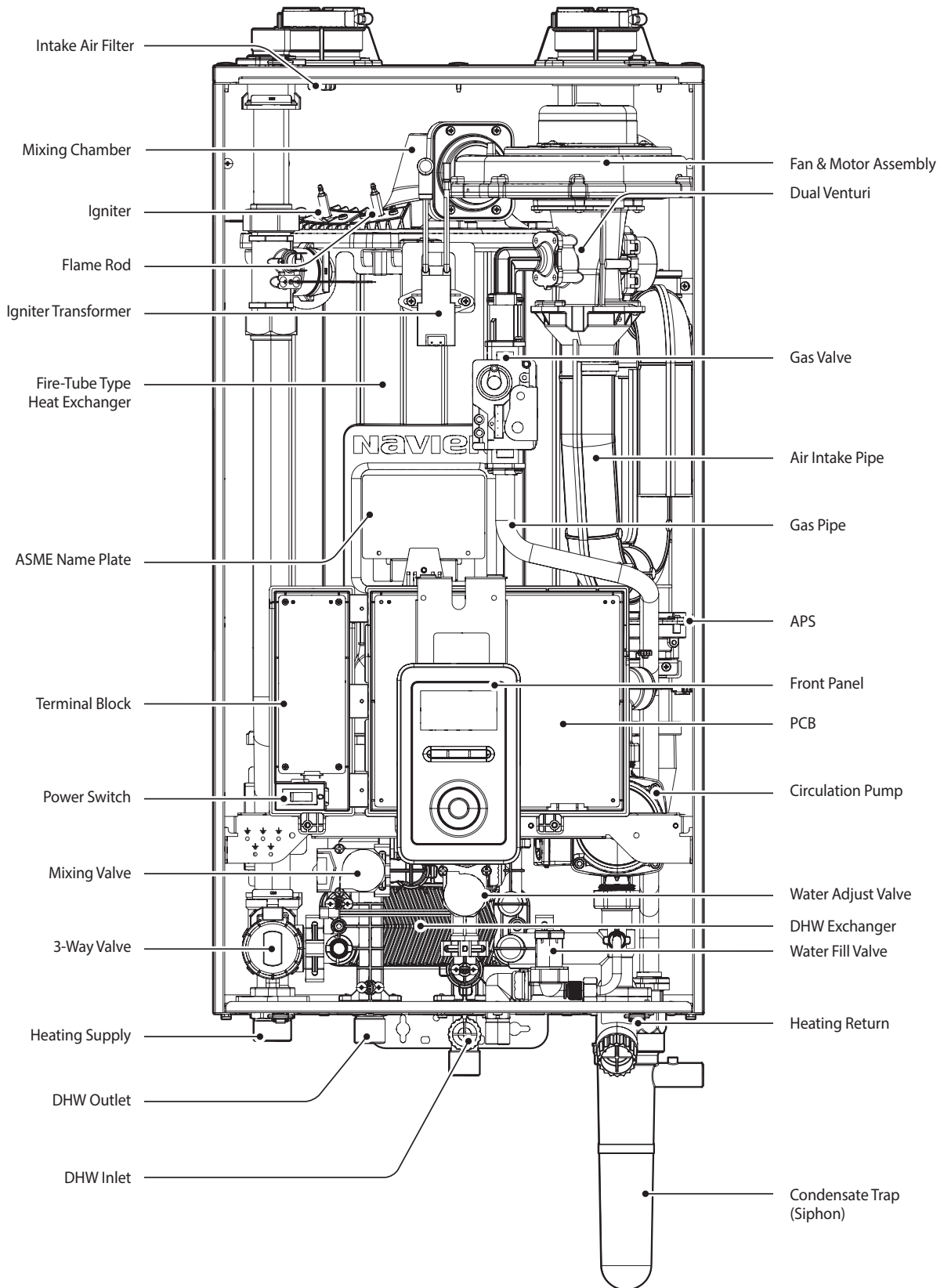

1.5 Dimensions

The following diagrams show the dimensions of the boiler and the table lists the supply connections.

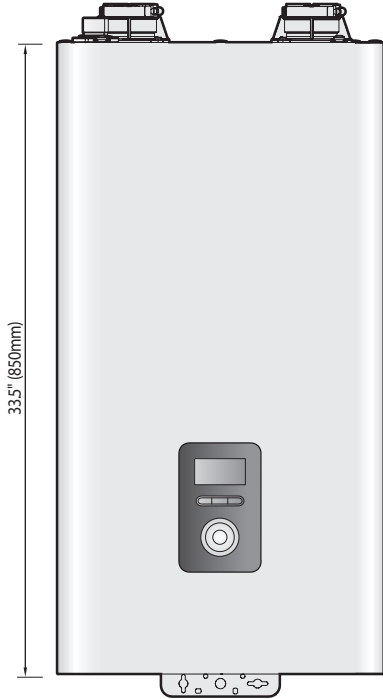

Supply Connections

| | Description | Diameter |
|---|-----------------------------------|----------|
| A | Air Intake | 2 in |
| B | Exhaust Gas Vent | 2 in |
| C | PRV-Air Vent Connection | 3/4 in |
| D | Heating Supply | 1 in |
| E | Heating Return | 1 in |
| F | Gas Connection | 3/4 in |
| G | Condensate Outlet | 1/2 in |
| H | Cold Water Inlet (DHW) | 3/4 in |
| I | Hot Water Outlet (DHW) | 3/4 in |
| J | Auto Feeder Inlet (Make-up Water) | 1/2 in |

Overhead View

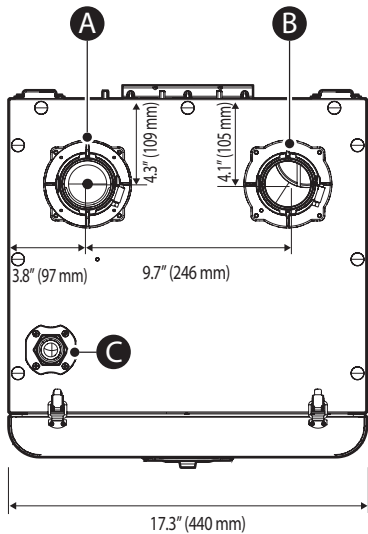



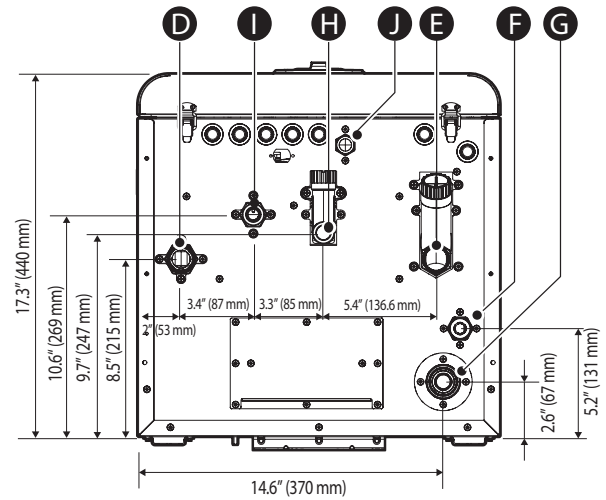



Supply Connections



1.6 Rating Plate

The Navien NFC boilers come from the factory configured for use with Natural Gas (NG). **Before starting the installation**, check the rating plate located on the side of the boiler to ensure that the boiler matches the gas type, gas pressure, water pressure, and electrical supply available in the installation location. **If the boiler does not match each of these ratings, do not install the boiler.** If conversion to Propane Gas is required, the included gas conversion kit must be used. Refer to “12.1 Gas & High Altitude Conversion” on page 103 for details.

Rating Plate, *Plaque Signalétique

| | | |
|---|--|--|
| Combination Boiler *Chaudière combinaison | |    |
| Navien Inc. 20 Goodyear, Irvine, CA 92618 Tel: (949) 420 - 0420 | | |
| Direct vent indoor installation, *Évacuation directe installation intérieure | |   |
| Model No., *Numéro de modèle | Type of Gas, *Type de gaz | |
| NFC-200 | NG |  |
| Max. Input Rating (DHW), *Entrée GPL max. | Min. Input Rating, *Débit calorifique max. | |
| 199,900 Btu/h | 18,000 Btu/h | |
| Max. Input Rating (Heating), *Entrée GPL max. | Heating Capacity, *Capacité de chauffage | |
| 199,900 Btu/h | 183,000 Btu/h | |
| Category of boiler, *Catégorie de chaudière | Net AHRI Rating, *Régime de AHRI | |
| Category IV | 159,000 Btu/h | |
| Max. Inlet Gas Pressure, *Pression max. de gaz d'entrée | 10.5 Inches W.C., *pouces W.C. | |
| Min. Inlet Gas Pressure, *Pression min. de gaz d'entrée | 3.5 Inches W.C., *pouces W.C. | |
| Manifold Pressure, *Pression d'admission | -0.20 Inches W.C., *pouces W.C. | |
| Electrical Rating, *Régime nominal électrique | AC *c.a. 120 Volts 60Hz Use less than 15 Amp, *Utilise moins de 15A | |
| Minimum relief valve capacity, *Capacité minimuma soupape. | 199 lbs/hr ANSI Z21.13-2017 • CSA 4.9-2017 | |

Orifices necessary for LP conversion are provided. *Les injecteurs nécessaires à la conversion au GPL sont fournis.

Failure to use the correct gas can cause problems which can result in death, serious injury or property damage. *Le fait de ne pas utiliser le bon gaz peut causer des problèmes qui peuvent mener à la mort, causer des blessures graves ou endommager la propriété.

Consult your installation manual for more information. *Consultez votre manuel d'installation pour plus d'information.

This appliance is certified for use at altitudes up to 4,500 ft (1,370 m) in accordance to the latest CAN/CGA 2.17-High Altitude Installation procedures at normal manifold pressure. This appliance has also been tested up to 10,100ft(3,078m).

For installations at altitudes up to 10,100ft(3,078m), follow the directions provided in the High Altitude Installations sections of the Installation Manual. *Cet appareil est certifié pour une utilisation à des altitudes de 0 à 4,500 pieds (1,370 m) conformément aux toutes les procédures d'installation à haute altitude CAN/CGA 2.17 à une pression normale. Cet appareil a été testé jusqu'à 10,1000 pieds (3,078 m). Pour les instructions d'installation à une altitude supérieure à 10,100 pieds, suivez les instructions fournies dans la section des installations à haute altitude du manuel d'installation.

This appliance must be installed in accordance with local codes or in the absence of local codes, the most recent edition of National Fuel Gas Code, ANSI Z223. 1, in Canada use CAN/CGA B149. 1 or 2 installation codes for Gas Burning Appliances.

***Cet appareil doit être installé conformément aux codes locaux, ou s'il n'y a pas de codes locaux, la plus récente version du National Fuel Gas Code des E.-U., ANSI Z223. 1, au Canada utilisez les codes d'installation CAN/CGA B149. 1 ou 2 pour les appareils à gaz.**

FOR YOUR SAFETY *POUR VOTRE SÉCURITÉ

Do not store or use gasoline or other flammable vapors and liquids in the vicinity of this or any other gas appliances. *Ne rangez pas et n'utilisez pas d'essence ou d'autres liquides ou vapeurs inflammables près de cet appareil ou de tout autre appareil électroménager.

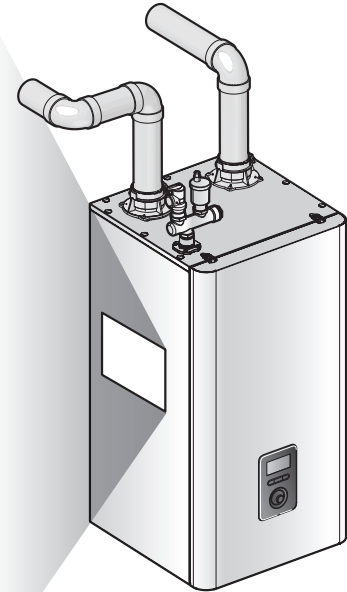

WARNING

Ensure that the gas type and power source specifications match what is listed on the rating plate. Using a different gas type will cause abnormal combustion and boiler malfunction. Using abnormally high or low AC voltage may cause abnormal operation, and may reduce the life expectancy of the product.

This appliance complies with the requirements of SCAQMD Rule 1146.2 for NOx emissions of 14 ng/J or 20 ppm at 3% O₂.

2. Installing the Boiler

2.1 Removing the Wood Pallet from the boiler

After you open the box, remove the wood pallet and the pallet brackets and then install the boiler.

CAUTION

After opening the box, verify that all included accessories are present in the accessory box and upper container.

Removing the Wood Pallet and the Pallet Brackets

1. Loosen the six screws that secure the wood pallet on the bottom left and right sides of the boiler.

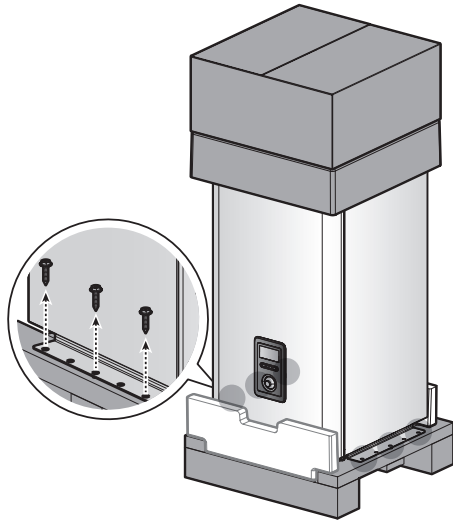

2. Remove the accessory box, the wood pallet, the upper container, and the lower pad.

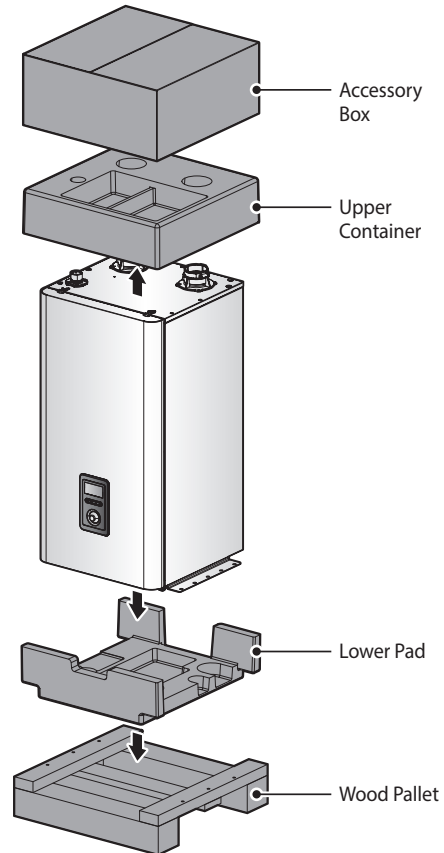

3. Loosen the four screws that secure the pallet brackets.

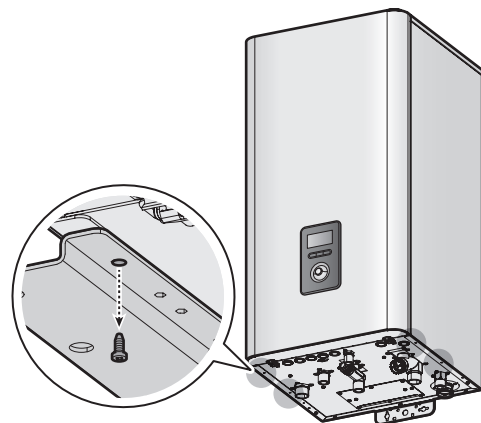

CAUTION

Keep the removed screws in a safe place. The screws will be used again in Step 5.

4. Remove the two pallet brackets.

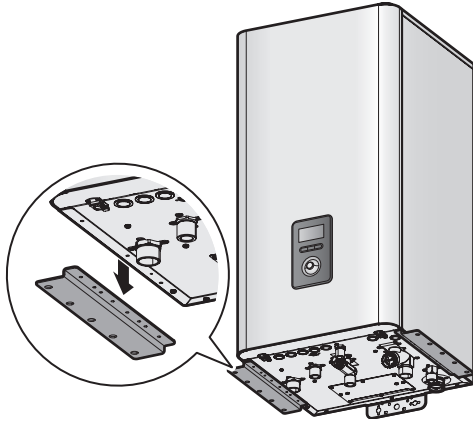

5. Tighten the four screws into the original position.

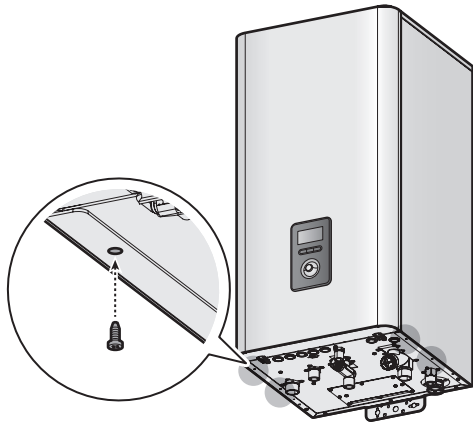

! CAUTION

Ensure that the screws have been retightened so that the boiler can maintain a proper airtight seal.

2.2 Choosing an Installation Location

When choosing an installation location, you must ensure that the location provides adequate clearance for the boiler, adequate venting and drainage options, and sufficient access to gas, water, and electrical supplies. Carefully consider the following factors when choosing an installation location:

Compliance Requirements

- Local, state, provincial, and national codes, laws, regulations, and ordinances.
- National Fuel Gas Code, ANSI Z223.1-latest edition.
- Standard for Controls and Safety Appliances for Automatically Fired Boilers, ANSI/ASME CSD-1, when required.
- National Electrical Code.
- For Canada only: B149.1 Installation Code, CSA C22.1 Canadian Electrical Code Part 1, CSA-B214-12 Installation code for hydronic heating systems, and any local codes.

Access to Utilities

- Water – the installation location should be near where the domestic water supply enters the building.
- Gas – the installation location should be near where the gas supply enters the building.
- Electricity – the installation location should be near where the electrical supply enters the building.

Humidity and Contact with Water

When installing the boiler, avoid places with excessive humidity. The boiler has electric gas ignition components. Moisture can get inside the boiler and damage the ignition system. The boiler must be installed in a way to ensure that the gas ignition system components are protected from water (dripping, spraying, rain, etc.) during operation and service.

Adequate Drainage

The boiler produces a significant amount of condensate during operation. The boiler should be located near a suitable drain and where damage from a possible leak will be minimal. Installing the boiler in a location without a drain will void the warranty and Navien will not be responsible for water damages that occur as a result. For more information about condensate drainage, refer to “3.3 Connecting the Condensate Drain” on page 25.

The boiler must be located in an area where leakage of the unit or connections will not result in damage to the area adjacent to the appliance or to lower floors of the structure. When such locations cannot be found, installation of an adequately drained drain pan under the boiler is highly recommended. When installing the drain pan, ensure that the installation does not restrict combustion air flow.

Adequate Venting and Ventilation

Select a location that requires minimal venting. Consider venting restrictions caused by windows, doors, air intakes, gas meters, foliage, and other buildings. For more information about venting, refer to “5. Venting the Boiler” on page 52.

To ensure adequate venting and ventilation, follow these guidelines:

- Maintain proper clearances from any openings in the building.
- Ensure that the vent termination is at least 12 in (305 mm) above ground, 12 in (305 mm) above the highest anticipated snow level, or as required by local codes, whichever is greater.
- Maintain a minimum clearance of 4 ft (1.2 m) from heating and cooling vents.
- Do not enclose the vent termination.
- Install the exhaust vent in an area that is free from any obstructions, where the exhaust will not accumulate.
- Do not install the boiler where moisture from the exhaust may discolor or damage walls.
- Do not install the boiler in bathrooms, bedrooms, or any other occupied rooms that are normally kept closed or not adequately ventilated.

Proximity to Fixtures and Appliances

Install the boiler near fixtures that deliver or use hot water, such as bathroom, kitchen, and laundry room faucets. Select a location that minimizes the water piping required between major fixtures. If the distances are long or if the user requires “instant” hot water, installation of a recirculation line which circulates domestic hot water back to the boiler from the furthest fixture is recommended. Insulate as much of the hot water supply and recirculation lines as possible. For more information about the water supply, refer to “3.2 Installing a Domestic Hot Water (DHW) System” on page 23.

Adequate Installation Clearances

CAUTION

Do not install the boiler on carpeting.

Install the boiler in an area that allows for service and maintenance access to utility connections, piping, filters, and traps. Based on the installation location, ensure that the following clearances are maintained:

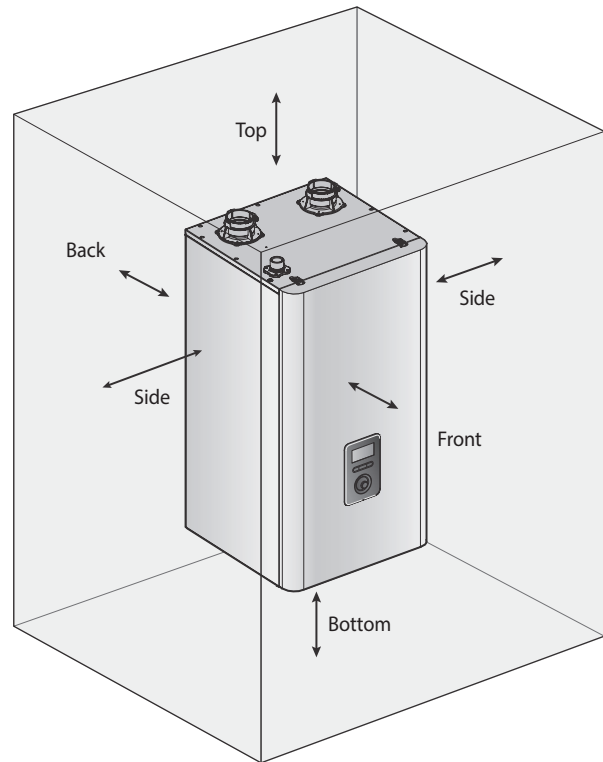

| Clearance from: | Indoor Installation |
|-----------------|------------------------|
| Top | 9 in (229 mm) minimum |
| Back | 0.5 in (13 mm) minimum |
| Front | 4 in (100 mm) minimum |
| Sides | 3 in (76 mm) minimum |
| Bottom | 12 in (300 mm) minimum |

! CAUTION

It is necessary to leave clearance for service access.

Clean, Debris and Chemical-free Combustion Air

- Do not install the boiler in areas where dust and debris may accumulate or where hair sprays, spray detergents, chlorine, or similar chemicals are used.
- Do not install the boiler in areas where gasoline or other flammables are used or stored.
- Ensure that combustible materials are stored away from the boiler and that hanging laundry or similar items do not obstruct access to the boiler or its venting.

High Elevation Installations

- This unit may be installed at elevations up to 10,100 ft (3,078 m) for use with natural gas and propane. Refer to "6. Setting the DIP Switches" on page 60 for the appropriate altitude setting.

2.3 Mounting the Boiler to the Wall

Navien NFC boilers come with an upper mounting bracket that is pre-drilled at 16 in (400 mm) on center for easy installation on standard wall studs. If the strength of the wall is insufficient or if the framing is non-standard or uneven, reinforce the area before installing the boiler. Avoid installation on common walls as the unit will make some operational noises while it is running.

To mount the boiler to the wall:

1. Affix the bracket securely to the wall and ensure that it is level and that it can support the weight of the boiler.
2. Align the grooves on the back of the boiler with the tongues on the mounting bracket and hang the boiler on the bracket. When mounted with the mounting bracket, the boiler will have a $\frac{5}{8}$ in (16 mm) clearance from the back of the wall.
3. Install two set screws through the bracket at the bottom of the boiler to secure the boiler on the wall.

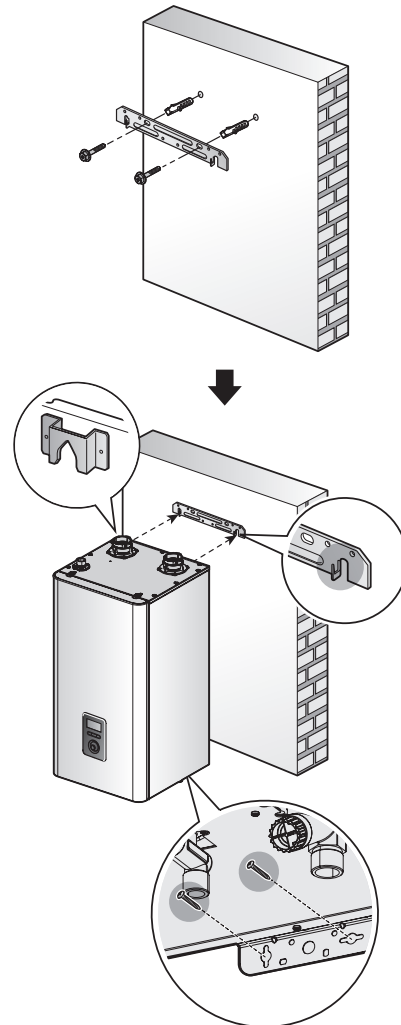

! WARNING

- **The boiler is heavy.** Always lift the unit with assistance. Be careful not to drop the boiler while lifting or handling it to avoid bodily injury or damage to the unit.
- **Do not** rest the boiler on the bottom end after removing it from the shipping carton. Doing so may result in excessive pressure on protruding pipes and resulting in product damage. If you must put the boiler down, lay it on its back or put it inside the protective shipping base.

! CAUTION

Do not mount the boiler to drywall that has not been reinforced.

3. Installing the System Piping

Prior to connecting piping to the boiler, flush the entire system to ensure it is free of sediment, flux, solder, scale, debris or other impurities that may be harmful to the system and boiler. During the assembly of the heating system, it is important to keep the inside of the piping free of any debris including construction dust, copper burr, sand and dirt.

For retrofits, all system piping including radiators, must be cleaned of all build-up including sludge and scale. All systems, old and new, must be cleaned to remove flux, grease and carbon residue. Navien recommends cleaning the boiler system with cleaning products specially formulated for boiler systems. For retrofit applications with heavy limescale and sludge deposits, a heavier duty cleaner may be required. For information on performing the cleaning, follow the instructions included with the boiler system cleaner products.

WARNING

Failure to rid the heating system of the contaminants listed above will void your warranty and may result in premature heat exchanger failure and property damage.

3.1 Installing a Space Heating System

The fire-tube type heat exchanger of the Navien NFC boiler is designed to attain the highest level of heat transfer in a compact design. To accomplish this, the heated gas flows through a series of small-diameter tubes, maximizing the heat transfer area. To maintain the efficient and reliable operation of the heat exchanger, and to avoid heat exchanger failure, it is critical to ensure the rules and guidelines in this section are followed.

CAUTION

Failure to follow the instructions provided in this section will void the warranty and may result in property damage, fire, serious injury or death.

3.1.1 Guidelines for a Space Heating Installation

Read and follow the guidelines listed below to ensure safe and proper installation of a boiler heating system.

Freeze Protection for a Space Heating System

- Freeze protection products may be used for the space heating system. Freeze protection for new or existing systems requires specially formulated glycol, which contains inhibitors to prevent the glycol from attacking the metallic system components.
- Before using freeze protection products, ensure that system fluid contains proper glycol concentration and the inhibitor level is appropriate. Navien recommends against exceeding a 50% concentration of glycol.
- When using the freeze protection products, the system must be tested at least once a year, and as recommended by the manufacturer of the glycol solution.
- When using the freeze protection products, allowance should be made for expansion of the glycol solution.
- Freeze damage is not covered by the warranty.
- The use of glycol results in a greater head loss due to its higher viscosity compared to water.

WARNING

For systems requiring freeze protection, use only inhibited propylene glycol, specially formulated for hydronic heating systems; use of other types of antifreeze may be harmful to the system and will void the warranty.

System Pressure

- The Navien NFC boiler is intended solely for use in pressurized closed loop heating systems operating with 12-80 psi water pressure at the boiler outlet. To obtain the minimum system design pressure, follow the piping diagrams illustrated in this section.
- The Navien NFC boiler's space heating system is not approved for operation in an "open system", thus it cannot be used for direct potable water heating or to process heating of any kind.

Oxygen Elimination

This boiler may only be installed in a pressurized closed-loop heating system, free of air (oxygen) and other impurities. To avoid the presence of oxygen, ensure all of the air is removed from the system during commissioning via strategically placed and adequately sized air removal appliances, located throughout the heating system.

Note See the examples of system application at the end of this section detailing the installation location of the air removal appliances, in case an additional air removal appliances is required for a specific application.

WARNING

- Immediately repair any leaks in the system piping to avoid adding make-up water. Make-up water adds oxygen and minerals to the system that may lead to heat exchanger failure.
- Failure to follow these instructions may result in poor performance, unnecessary wear of system components and premature failure.

CAUTION

Do not solder piping directly onto the water connections, as the heat may cause damage to internal components. Use threaded water connections only.

3.1.2 Essential Elements in a Space Heating System

Air Vent

The Navien NFC boiler comes with an air vent and an adapter bushing that must be connected to the air vent connection. The vent efficiently removes the air from the boiler. The following figure illustrates an example of a typical air vent installation.

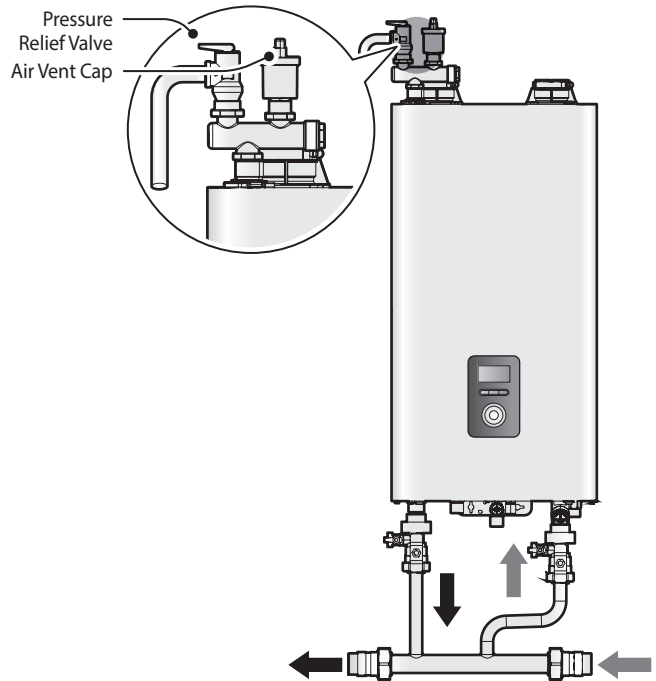

Note After inserting the PRV-air vent adapter into the connection on top of the unit, install the provided clip to secure the adapter to the fitting.

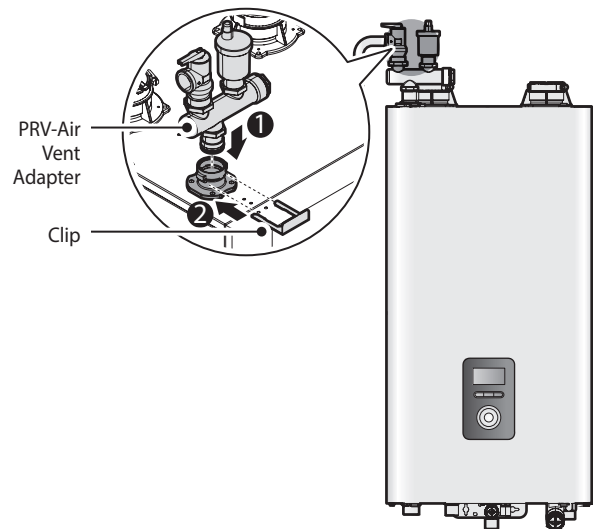

Also, an external LWCO and a pressure relief valve can be installed at the air vent connection. Refer to “Low Water Cut Off (LWCO) Appliance” on page 21 and “Pressure Relief Valve” on page 21.

Note Before installing the vent line and any vent fittings, you must be familiar with the LWCO and pressure relief valve installation guidelines.

Low Water Cut Off (LWCO) Appliance

Internal LWCO

The Navien NFC boiler is equipped with a factory-installed, pressure-sensing type low water cutoff (LWCO) appliance. The minimum operation pressure for this appliance is 6 psi by default.

Note When the built-in water pressure sensor detects insufficient water level in the boiler, error code E302 is displayed on the front panel requiring a manual boiler reset.

Refer to local codes to determine if a LWCO appliance is required for your system and ensure that the built-in appliance meets the requirements.

External LWCO

If local codes require a separate LWCO appliance, install one separately. A LWCO may be connected to the included PRV-Air vent Adapter. The following illustration shows an example of a separately installed external LWCO.

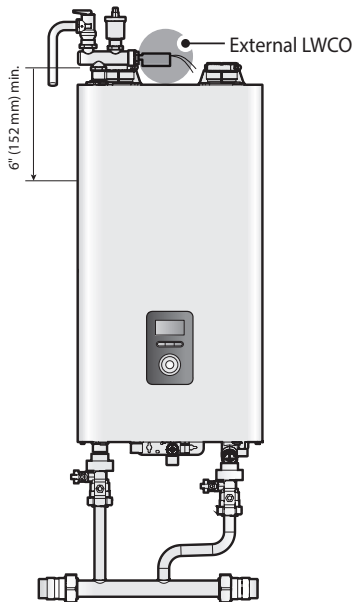

The external LWCO must be installed at least 6 in (152 mm) above the top of the heat exchanger. Refer to “3.7.2 Wiring Diagram - External LWCO” on page 38 for typical wiring connections of the LWCO to the boiler PCB.

Backflow Preventer

Install a backflow preventer valve in the make-up water supply to the unit as required by local codes.

Expansion Tank

An expansion tank must be installed in the space heating piping to prevent excessive pressure from building in the system. See the examples of system application at the end of this section for the installation location. Refer to the expansion tank manufacturer's instructions for additional details.

Follow the guidelines below when installing an expansion tank.

- Connect an air separator to the expansion tank only if the air separator is located on the suction side of the system pump.
- Install the make-up water connection at the same location as the expansion tank's connection to the system.
- When replacing an expansion tank, consult the expansion tank manufacturer's literature for proper sizing.
- For diaphragm expansion tanks, always install an automatic air vent on the top side of the air separator to remove residual air from the system.

Isolation Valves and Unions

- Full port ball valves are required for the boiler system. Failure to use full port ball valves could result in a restricted flow rate through the boiler.
- Check valves are recommended for installation. Failure to install check valves could result in a reverse flow condition during pump(s) off cycle.
- Unions are recommended for unit serviceability.

Magnetic Filtration

The Navien NFC boiler comes with the NavicClean hydronic heating filter. This must be connected to the space heating return in the near boiler piping to protect the boiler from iron oxide (magnetite). Refer to the included instructions for installation details.

Pressure Relief Valve

To complete the space heating system installation, you must install a $\frac{3}{4}$ in, 30 to 80 psi (max) pressure relief valve on the space heating hot water outlet. An ASME approved HV pressure relief valve for space heating system is supplied with the boiler.



WARNING

- Installing the pressure relief valve improperly may result in property damage, personal injury, or death. Follow all instructions and guidelines when installing the pressure relief valve. The valve should be installed only by a licensed professional.
- The pressure relief valve must be installed at the boiler outlet and in the vertical position, as shown in this section, with the drain pipe outlet exiting the side of the pressure relief valve horizontally and elbowing down.



CAUTION

Install the pressure relief valve as close to the boiler as possible. No other valve should be installed between the pressure relief valve and boiler.

When installing the pressure relief valve, follow these guidelines:

- Ensure that the valve's discharge capacity is equal to or greater than the maximum pressure rating of the boiler's space heating system.
- Ensure that the maximum BTU/H rating on the pressure relief valve is equal to or greater than the maximum input BTU/H rating of the boiler.
- Direct the discharge piping of the pressure relief valve so that hot water does not splash on the operator or equipment.
- Attach the discharge line to the pressure relief valve and install the end of the line within 6-12 in (150-300 mm) above the floor.
- Ensure that the discharge line provides complete and unobstructed drainage. Do not install a reducing coupling or other restrictions on the discharge line.

If the relief valve discharges periodically, this may be caused by thermal expansion when the expansion tank is full or undersized. Do not plug the relief valve.

The illustration below shows an example of a pressure relief valve and an air vent installed with the PRV-air vent adapter included in the accessory box.

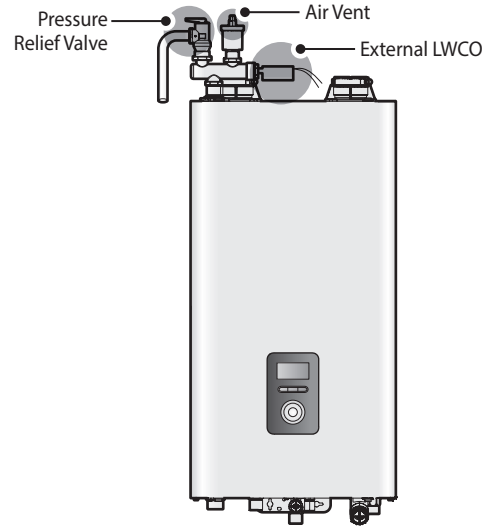

Method 1.

Note

- Depending on the installation conditions, pressure relief valves (not included and for separate purchase) of up to 80 psi can be used.
- Refer to "11.4.3 Setting the Operation Parameters - 16. High Sys Pressure" on page 96 to adjust the upper limit pressure lockout setting when using a higher rated valve.
- Ensure that the manifold system included in the accessory box must be installed.



CAUTION

All field supplied pressure relief valves must be ASME certified.

3.1.3 Space Heating System Piping

When connecting the space heating system, follow these guidelines:

- Tighten the connection valves with care to avoid damage.
- After installing the boiler, clean the strainer for space heating return. Then, test the boiler for proper space heating flow and inspect for leaks. Instruct the boiler owner that the strainer must be cleaned periodically to maintain proper space heating water flow.

The Navien manifold system allows for easy separation of the Boiler-Primary loop from the System-Secondary loop(s). Refer to the following illustration for a typical water piping example with a Navien manifold system.

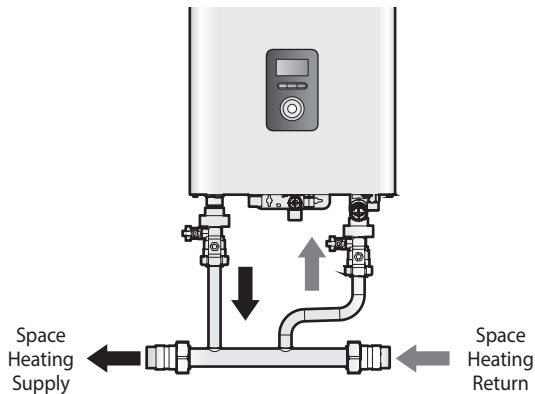

Note Refer to the following illustration for details on installing the NFC-175/200 Manifold System (Part Number: 30021988A) to the valve kits.

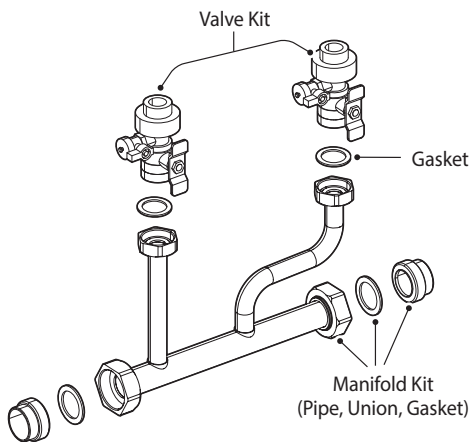

Also, check that a pipe, unions, gaskets, and valves are all included in the Manifold kit box and the Valve kit box. After installing the manifold and valve kits, ensure that the fittings, such as the unions and gaskets, are properly sealed with the pipe.

3.2 Installing a Domestic Hot Water (DHW) System

The Navien NFC boiler provides domestic hot water continuously when water flow is detected by the flow sensor. This method is the most efficient means of heating water by allowing the boiler to operate at a lower return water temperature by minimizing standby losses, thus increasing combustion efficiency.

3.2.1 Guidelines for the DHW System

With its multi-purpose design, the Navien NFC boiler provides hot water on demand. This means that the boiler produces DHW only when the user demands it. The boiler recognizes a DHW demand when the flow sensor detects a DHW flow of approximately 0.5 GPM or greater. Once the flow sensor detects the flow, the boiler immediately goes into DHW mode regardless of the status of the space heating system. Read and follow the guidelines listed below to ensure safe and proper installation of a boiler heating system.

Scald Hazard

Hotter water increases the risk of scald injury. There is a hot water scald potential if the DHW temperature is set too high. Be sure to follow the adjustment instructions in the boiler's operation manual.

About the DHW Quality

Proper maintenance of the boiler is required when water quality does not meet EPA standards. Damage caused by poor water quality is not covered under warranty. The following table shows the maximum contaminant levels allowed, based on the EPA National Secondary Drinking Water Regulations (40 CFR Part 143.3). If you suspect that your water is contaminated in any way, discontinue use of the DHW and contact an authorized technician or licensed professional.

| Contaminant | Maximum Allowable Level |
|------------------------------|-----------------------------------|
| Total Hardness | Up to 200 mg/l (12 grains/gallon) |
| Aluminum | 0.05 to 0.2 mg/l |
| Chloride | Up to 250 mg/l |
| Copper | Up to 1.0 mg/l |
| Iron | Up to 0.3 mg/l |
| Manganese | Up to 0.05 mg/l |
| pH | 6.5 to 8.5 |
| Sulfate | Up to 250 mg/l |
| Total Dissolved Solids (TDS) | Up to 500 mg/l |
| Zinc | Up to 5 mg/l |

Navien is not responsible for performance issues of the domestic system by scaling or accumulation of dirt; suitable steps shall be taken by the installer and user to avoid water quality related issues. Freeze Protection Navien recommends heat tracing and insulating the DHW water pipes. Pipe enclosures may be packed with insulation for added freeze protection. Freeze damage is not covered by the warranty.

3.2.2 Essential Elements in a DHW System

DHW Heat Exchanger

The DHW heat exchanger installed inside the Navien NFC boiler has been tested and certified in accordance with the latest IAPMO standard PS 92.

Drain and Isolation Valves

Install drain and isolation valves on the inlet and outlet of the DHW heat exchanger, so it can be flushed free of possible build-up caused by dirt or hard water.

Pressure Relief Valve for DHW

To complete the installation of the DHW system, you must install an approved $\frac{3}{4}$ in, maximum 150 psi pressure relief valve on the hot water outlet. The Navien NFC boiler has a built-in high temperature shut off switch, so install a “pressure only” relief valve.

WARNING

Installing the pressure relief valve improperly may result in property damage, personal injury, or death. Follow all instructions and guidelines when installing the pressure relief valve. The valve should be installed only by a licensed professional.

The DHW pressure relief valve is not supplied, but is required.

The following examples are pressure relief valves approved for use with the boiler:

- Wilkins P-1000A (Zurn Industries)
- Conbraco 17-402-04
- Watts Industries 3L (M7)
- Cash Acme FWL-2, $\frac{3}{4}$ in

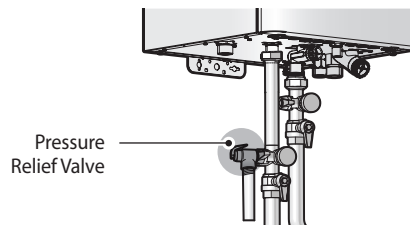

CAUTION

Install the pressure relief valve as close to the boiler as possible. No other valve should be installed between the pressure relief valve and boiler.

When installing pressure relief valve, follow these guidelines:

- Ensure that the valve's discharge capacity is equal to or greater than the maximum pressure rating of the boiler's DHW system.
- Ensure that the maximum BTU/H rating on the pressure relief valve is equal to or greater than the maximum input BTU/H rating of the boiler.
- Direct the discharge piping of the pressure relief valve so that hot water does not splash on operator, or any nearby equipment.
- Attach the discharge line to the pressure relief valve and run the end of the line to within 6-12 in (150-300 mm) of the floor.
- Ensure that the discharge line allows for free and complete drainage without restriction. Do not install a reducing coupling or other restrictions on the discharge line.
- If the relief valve discharges periodically, this may be due to thermal expansion in a closed water supply system. Contact the water supplier or local plumbing inspector on how to correct the situation. Do not plug the relief valve.

3.2.3 DHW System Piping

CAUTION

To comply with ASME or CRN requirements, an additional high temperature limitation appliance may be needed. Consult your local code requirements to determine if this appliance is required.

Refer to the following illustration for a typical DHW piping example for the boiler.

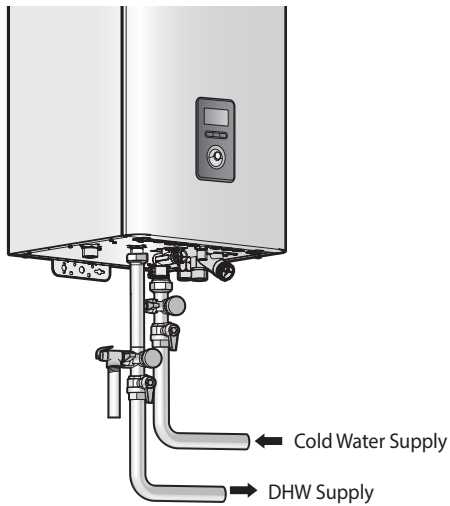

When installing the DHW system, follow these guidelines:

- Use only pipes, fittings, valves, and other components (such as solder), that are approved for use in potable water systems.
- Tighten the connection valves with care to avoid damage.
- Navien recommends using unions and manual shut-off valves on the cold water inlet and DHW outlet.
- Keep the hot water piping system as short as possible, to deliver hot water to the fixtures more quickly.
- Recirculation controls are included with the boiler for use of an optional external recirculation system.
- To conserve water and energy, insulate the DHW supply and DHW recirculation lines (if applicable). Do not cover the drains or pressure relief valves.
- After installing the boiler, clean the cold water inlet filter. Then, test the boiler for proper DHW supply and inspect for leaks. Instruct the boiler owner that the filter must be cleaned periodically to maintain proper DHW flow.

3.3 Connecting the Condensate Drain

The Navien NFC boiler creates condensation when it operates. This condensation has an acidic pH of 3-5. Follow all local codes and regulations when disposing of condensate from the boiler. We recommend draining the condensate into a laundry tub, as the alkali in laundry detergent will neutralize the acid in the condensate. However, other suitable waste drain locations may be used according to the local codes.

CAUTION

- Do not cap or plug the integrated condensate line. If prevented from draining, condensate can damage the boiler.
- The condensate line must have a negative slope to drain properly.

To attach the condensate trap to the boiler:

1. Check the components of the condensate trap.



2. Insert the condensate trap to the drain adapter at the bottom of the boiler.

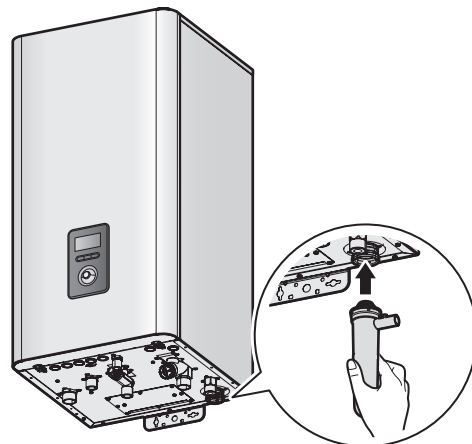

3. Attach the clip to the condensate trap.

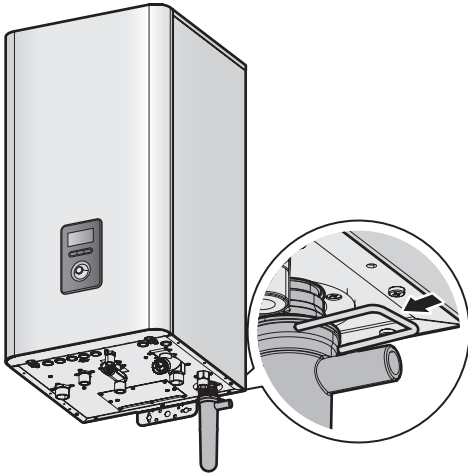

4. Ensure that the condensate trap is firmly fixed to the bottom of the boiler.

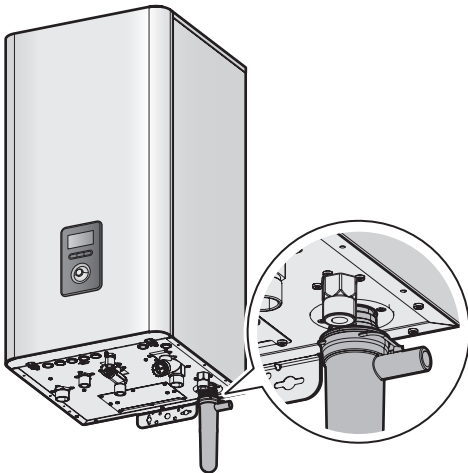

Before connecting the condensate drain, choose one of the following disposal options:

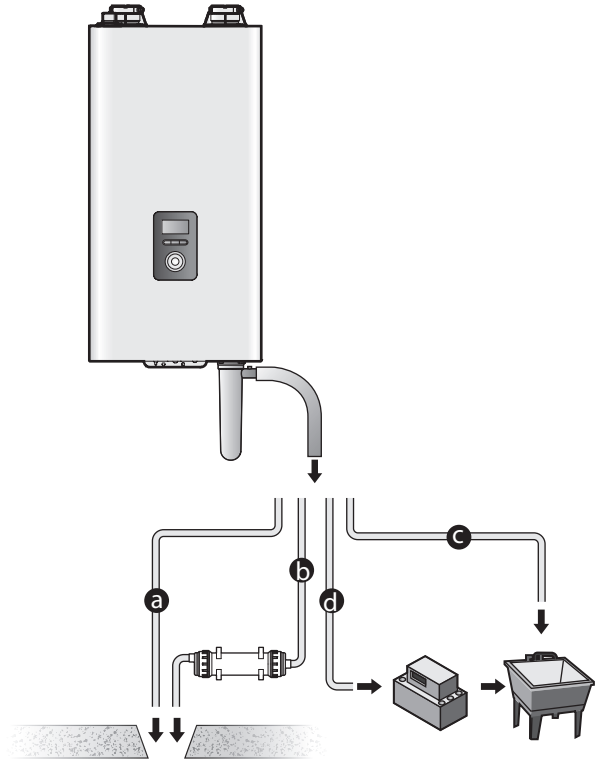

- a. From the boiler directly into an external drain.

Note Do not install a fixed connection for the drain.

- b. From the boiler, through a neutralizing agent, and then into an external drain (refer to "3.3.1 Condensate Neutralizer Kit" on page 27).

Note If you choose this option, the neutralizing agent must be replaced periodically. Depletion of the neutralizing agent will vary, based on the usage rate of the boiler. During the first year of operation, the neutralizer should be checked every few months for depletion and replaced as needed.

- c. From the boiler into a laundry tub.

Note The bottom of the boiler must be higher than the top of the laundry tub to use this option. The condensate line must have a negative slope to drain properly.

- d. From the boiler into a condensate pump, and then into a laundry tub.

Note A pump can be used when there is a long distance between the boiler and the laundry tub or when the bottom of the boiler is lower than the top of the laundry tub.

To connect the condensate drain:

1. Connect a drain line to the $\frac{1}{2}$ in fitting at the bottom of the boiler.
Use only corrosion-resistant material for the drain line, such as PVC or CPVC. Do not reduce the size of this fitting or the drain line to less than $\frac{1}{2}$ in.

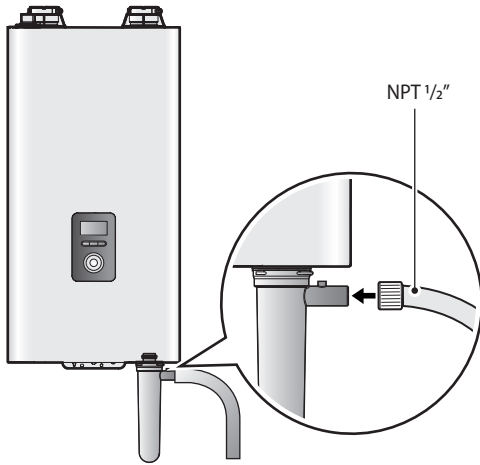

2. Place the free end of the drain line into an appropriate drain.
3. If you are using a condensate pump, ensure that the pump allows for up to 3 GPH of drainage for each boiler in the system.
4. If you are not using a condensate pump, ensure that the drain line is pitched downward at a minimum slope of $\frac{1}{4}$ in per foot.

3.3.1 Condensate Neutralizer Kit

WARNING

- To avoid damaging the appliance, the neutralizer inlet and discharge must be lower than the condensate drain.
- Do NOT allow exhaust flue gases to vent through the neutralizer. Leakage can cause injury or death from carbon monoxide.
- The connection between the appliance and the neutralizer must be installed at a lower point than the condensate drain fitting on the appliance to prevent the backflow of condensate.
- Do not connect more than one appliance to the neutralizer.

If option 'b' (p. 25) is selected as the disposal option, the Navien condensate neutralizer kit is recommended. The condensate from the appliance flows through the neutralizing media and increases the pH of the condensate. An increased pH prevents corrosion of the installation's drainage system and the public sewer system.

Installation

- The inlet has a center connection port and the outlet has an offset connection.
- Install the neutralizer on the wall or the floor and secure it using the brackets supplied with the kit.
- If the neutralizer is installed horizontally, rotate the neutralizer to position the outlet at the highest point (Figure 1).
- If the neutralizer is mounted vertically, ensure that the outlet is higher than the inlet (Figure 2).
- Ensure that the condensate runs freely to the drain.
- Use corrosion resistant piping and secure all piping to prevent movement.

Note Do not install condensate piping in areas where the temperature drops below freezing point. Protect piping in high pedestrian areas from damage and vibration.

- If local codes permit, install a Y-fitting as a bypass drain for increased safety when the condensate drain is blocked. Connect the Y-fitting as shown in the installation diagram and ensure that the condensate runs freely to the drain.
- Ensure that the discharge connection is accessible. Access to the discharge connection is required for maintenance and pH testing.
- If there is insufficient gradient for drainage, install a drainage pump designed for boiler and water heater condensate removal.

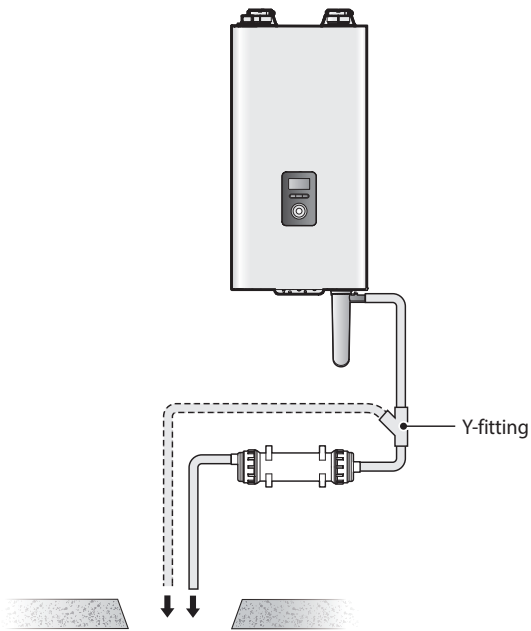

Figure 1. Horizontal installation

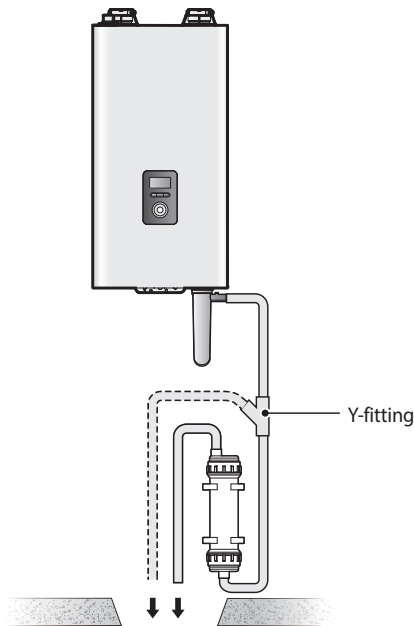

Figure 2. Vertical installation

Maintenance

Periodically monitor the level of media in the neutralizer and test the pH level at the outlet. We recommend an annual pH test using recognized test strips or an electronic pH meter to obtain precise measurements. Replace the neutralizing media when the pH drops below the minimum level required by the local water authority. If the pH level is not specified, replace the neutralizing media when the pH is below 6.0. For replacement media, contact your local Navien distributor.

3.4 Filling the System

Before filling the boiler, loosen the air vent cap to enable the system to fill properly.

Tighten the air vent cap and the vent screws when the system is full.

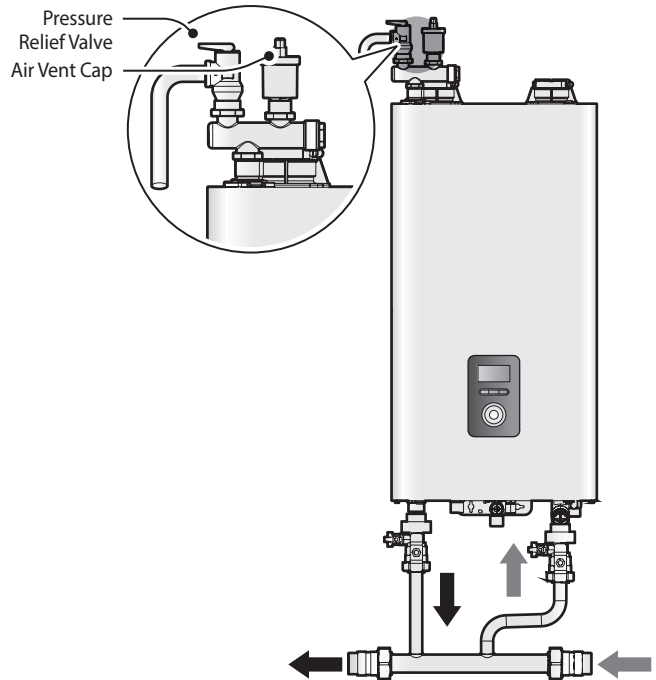

Note

Ensure that the vent cap is re-installed and the vent screws on the system and boiler pumps are properly tightened before testing or operating the system.

3.4.1 Built-in Water Fill Connection

The Navien NFC boiler is equipped with an auto-feeding water connection and motorized feeding valve. Therefore, installation of additional system water fill connection is not necessary in most cases. See the following figure for an example of a water fill installation using the built-in connection.

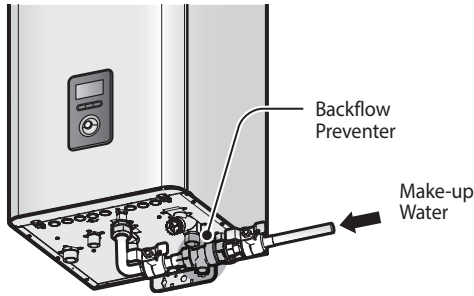

3.4.2 External Water Fill Connection

External water fill connection may be installed on the system piping if it is required for specific applications. See the following figure for an example of external water fill installation on the system piping.

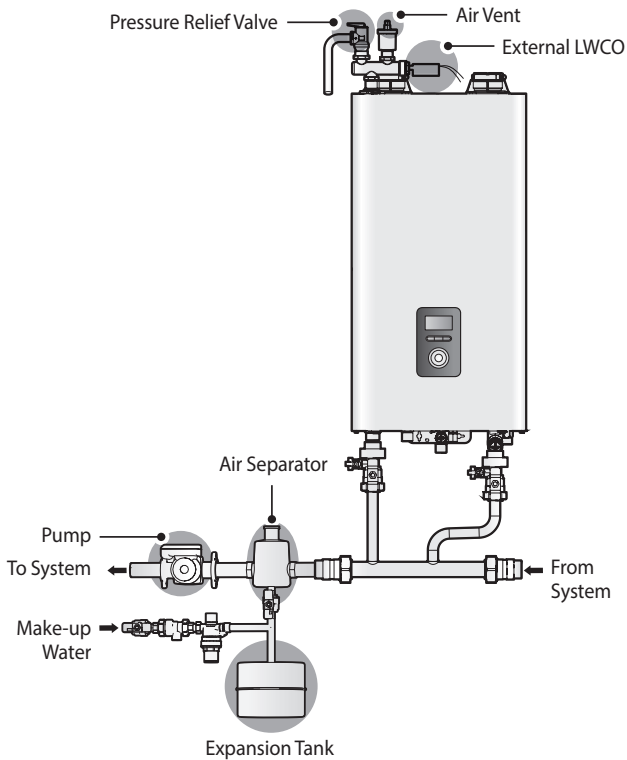

3.5 Testing the Water System

WARNING

Ensure that the boiler is full of water before firing the burner. Operating the unit without completely filling it will damage the boiler. Such damage is not covered by the warranty, and may result in property damage, severe personal injury, or death.

Perform a fill test after installing the boiler's water system to make sure that the system has been installed properly. Follow the instructions below to perform a fill test on the water system.

1. Fill the system only after ensuring that the water chemistry meets the requirements.

| Contaminant | Maximum Allowable Level |
|------------------------------|-----------------------------------|
| Total Hardness | Up to 200 mg/l (12 grains/gallon) |
| Aluminum | 0.05 to 0.2 mg/l |
| Chloride | Up to 250 mg/l |
| Copper | Up to 1.0 mg/l |
| Iron | Up to 0.3 mg/l |
| Manganese | Up to 0.05 mg/l |
| pH | 6.5 to 8.5 |
| Sulfate | Up to 205 mg/l |
| Total Dissolved Solids (TDS) | Up to 500 mg/l |
| Zinc | Up to 5 mg/l |
| Chlorine | Up to 4 mg/l |

Note Proper maintenance of the boiler is required when water quality does not meet standards. Damage caused by poor water quality is not covered under warranty. The table above shows the maximum contaminant levels allowed. If you suspect that your water is contaminated in any way, discontinue the use of the boiler and contact an authorized technician or licensed professional.

2. Close the manual and automatic air vents and the boiler drain valve.
3. Fill the boiler to the correct system pressure. The correct pressure will vary with each application. The typical cold water fill pressure for a residential system is 12 psi. The pressure will rise when the boiler is turned on and the system water temperature increases. The operating pressure must never exceed the relief valve pressure setting.
4. At initial fill and during boiler start-up and testing, check the system thoroughly for leaks. Repair any leaks before proceeding further.



WARNING

Eliminate all system leaks. The continual introduction of fresh makeup water will reduce boiler life. Minerals can build up in the heat exchanger, reducing heat transfer, overheating the heat exchanger and causing heat exchanger failure.

The system may have residual substances that could affect water chemistry. After the system has been filled and leak tested, verify that water pH and chlorine concentrations are within the acceptable range by performing sample testing.



CAUTION

Before operating the boiler for the first time, ensure that the boiler system is filled with water. Purge the air inside the system to avoid damage to the boiler.

3.6 Considerations for System Applications

Read and follow the guidelines listed below when installing system piping for the Navien NFC boiler:

- System application drawings are intended to explain the system piping concept only.
- For the upstream side of all pumps, use straight pipes with a minimum inside diameter of 1/2 in (12 mm).
- Provide a system expansion tank following the guidelines on page 21.
- Installations must comply with all local codes. In Massachusetts, a vacuum relief valve must be installed in the cold water line per 248 CMR.

Air Removal

The boiler and system piping layout must be configured to promote the removal of air from the system. Air vents and bleeders must be strategically placed throughout the system to aid in purging the air from the system during commissioning of the boiler. The system must also employ the use of an air removal appliance, such as an air scoop or an air eliminator designed to remove the air from the water as it flows through the system.

Follow the installation instructions included with the air removal appliance when placing it in the system; air removal appliances generally work better when placed higher in the system. Always locate air removal appliances in areas of the system that have a guaranteed positive pressure, e.g., in close proximity to the water fill and expansion tank.

Note

Connecting an air vent on top of the boiler is recommended.

Expansion Tank

The expansion tank must be sized in accordance with the water volume of the system as well as the firing rate of the appliance. It is important to locate the expansion tank, and make-up water connection, on the inlet side of any pump in the system, as doing so will guarantee the lowest pressure in the system will be at least equal to the tank and make-up water pressure.

Ensure the expansion tank cannot become isolated from the boiler anytime the system is operating. Failure to follow these instructions may lead to discharge from the pressure relief valve, which may result in property damage or injury.

Note

The installation of check valves, motorized valves or other shutoff appliances (other than for the purpose of servicing) are not permitted between the location of the "Closely Spaced Tees" and the expansion tank.

Air Handler Interface

The Navien NFC boiler can control the operation of an air handler when a thermostat is used in combination with the air handling unit. The Air Handler Interface is designed to stop air handler operation when the boiler's space heating function is not operating due to DHW supply demands, boiler errors, or low water conditions.

The air handler contacts (A/H) turn off when the following conditions arise:

- The PCB DIP SW2 #7 is set to ON.
- Thermostat is turned off.
- The boiler is supplying DHW, or it is in stand-by mode for DHW demand.
- Level 2 or higher errors occur.
- The boiler is turned off.

Thermostat Configuration for the Air Handler Interface

Set the PCB DIP SW2 #7 to down position (OFF) to use a thermostat with the Air Handler.

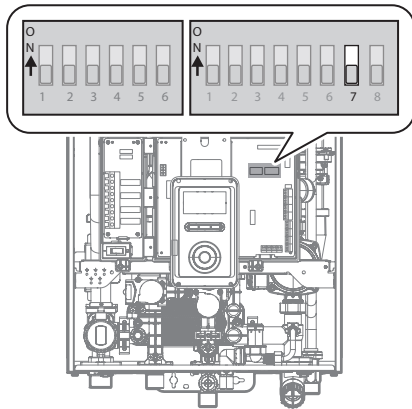

Refer to the "3.1.1 Guidelines for a Space Heating Installation" on page 45 for wiring connections.

WARNING

- The boiler, when used in conjunction with an air conditioning system, must be installed so that the chilled medium is piped in parallel with the heating boiler. Appropriate valves must be used to prevent the chilled medium from entering the boiler.
- If the boiler is connected to heating coils located in air handling units where they can be exposed to refrigerated air, use flow control valves or other automatic means to prevent gravity circulation of the boiler water during the cooling cycle.

3.6.1 Temperature Control Device Applications

NFC series boilers come with water adjustment valves and mixing valves included as to ensure a stable supply of hot water without requirements for additional direct water pressure control valves (flow restrictors) or mechanical mixing valves.

- When setting up the system, do not install water pressure control valves or flow restrictors on the direct water supply lines.
- When setting up the system, do not install additional mechanical mixing valves on the DHW supply line.

Water Adjustment Valve

The adjustment valve works in conjunction with the flow sensor to detect and control the direct water flow within the system, and is installed on the water piping module. Refer to "1.4 Components" on page 11 for details.

Mixing Valve

The mixing valve controls the amount of cold water that is mixed with the hot water in order to provide a stable supply of DHW. It is installed on the water pipe module. Refer to "1.4 Components" on page 11 for details.

3.6.2 Examples of System Applications

Refer to the following examples to properly implement a system for space heating, DHW supply, or both. These examples are provided to suggest basic guidelines when you install the boiler system. However, the actual installation may vary depending on the circumstances, local building codes, or state regulations. Check the local building codes and state regulations thoroughly before installation, and comply with them fully.

3.6.3 System Application - Zone System with Pumps (Primary/Secondary Piping)

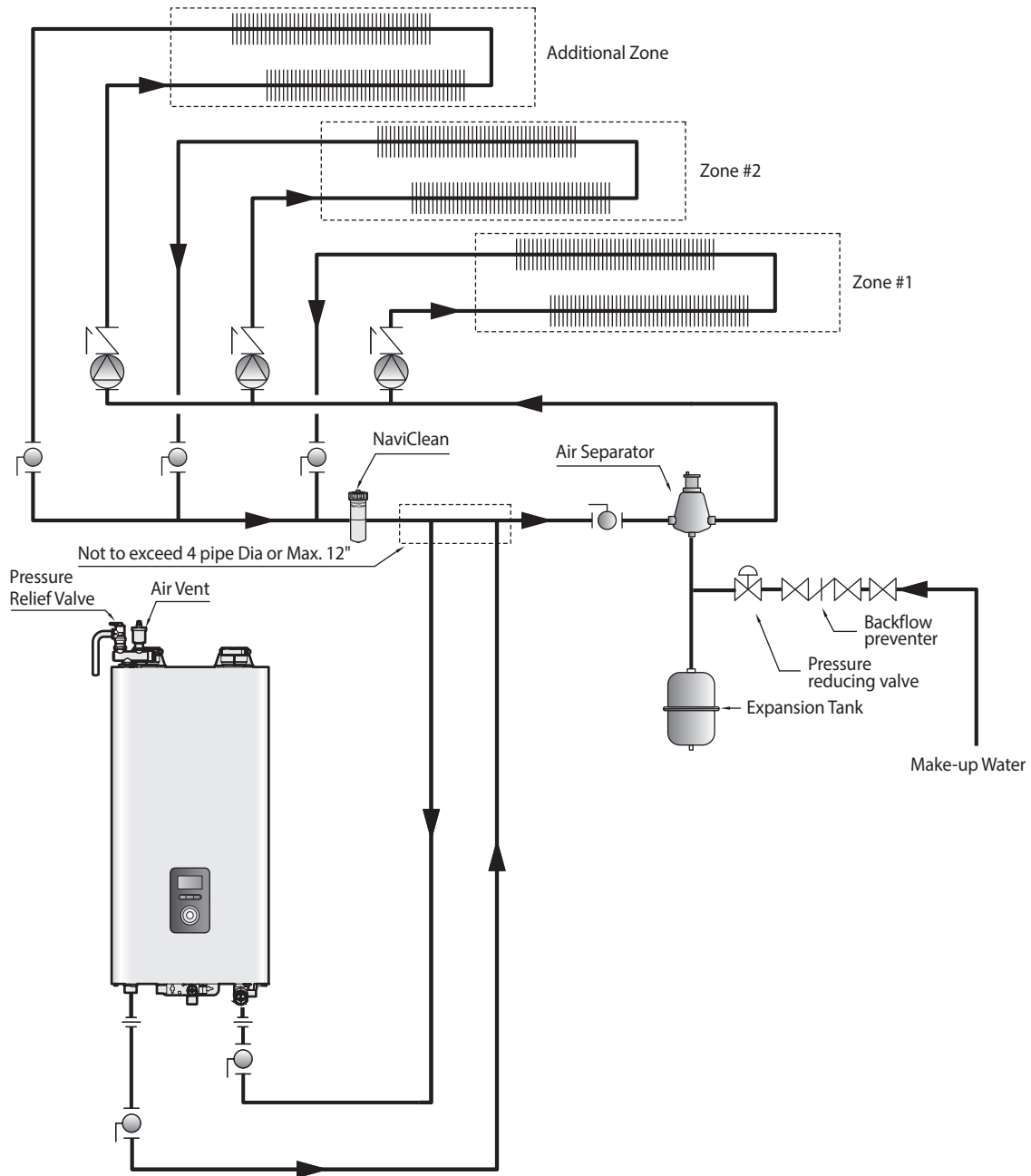

Note

- System application drawings are intended to explain the system piping concept only.
- Install a NaviClean filter in the system return to remove foreign objects from the system. Foreign objects inside the system may result in abnormal system operation.
- Refer to "3.4 Filling the System" on page 28 for make-up water connections and refer to the requirements of your local codes to ensure compliance.
- Use a pump with an integral check valve or install a check valve at the pump outlet.
- Refer to "3.7.3 Wiring Diagram - Zone Pump System" on page 39 for wiring connections.

3.6.4 System Application - Air Handler System

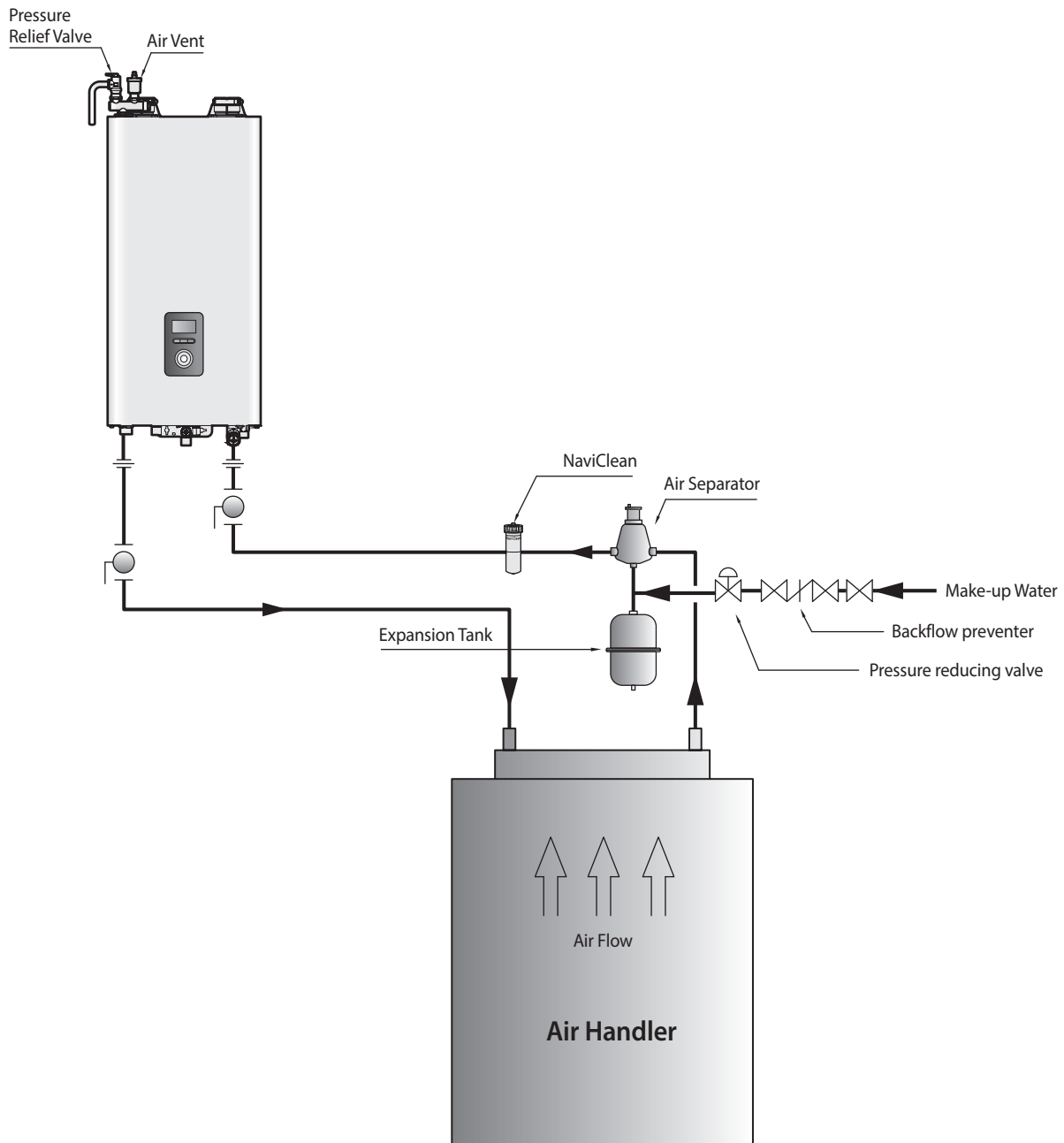

Note

- System application drawings are intended to explain the system piping concept only.
- Install a NaviClean filter in the system return to remove foreign objects from the system. Foreign objects inside the system may result in abnormal system operation.
- Refer to “3.4 Filling the System” on page 28 for make-up water connections and refer to the requirements of your local codes to ensure compliance.
- Air handlers with an internal pump shall be piped either with a crossover pipe at the AHU or in a primary/secondary configuration with the boiler.
- Refer to the “3.7.8 Wiring Diagram - Air Handler” on page 45 for wiring connections.
- You can use a secondary piping configuration for the air handler system to maintain optimal flow and heat capacity.

3.6.5 System Application - Combi Pre-Heat Mode

Combi pre-heat allows NFC boilers to pre-heat to ensure a quick supply of hot water when there is no external recirculation system. This mode is enabled by default. (Refer to the combi pre-heat section in "11.3.4 Setting the DHW Operation" on page 90 for details.)

3.6.6 System Application - External Recirculation with NaviCirc

The following pump models are recommended for use with the NFC boiler and DHW recirculation systems. When using the indicated pump models, observe the following maximum recirculation pipe lengths:

- 100 feet (30 m) equivalent length of 1/2" copper pipe
- 400 feet (120 m) equivalent length of 3/4" copper pipe

External Recirculation Mode

For best performance, select the Intelligent or Weekly option in the External recirculation DHW recirculation menu. To use the aquastat mode, install an aquastat to the DHW pipe line and connect to the CNC6 terminal on the PCB. (Refer to "3.7.4 Wiring Diagram - Zone Pump System with DHW Recirculation" on page 41 for details.)

Note Combi pre-heat is the default mode for DHW recirculation. To select external recirculation, refer to the combi pre-heat and external recirculation sections in "11.3.4 Setting the DHW Operation" on page 90 for details.

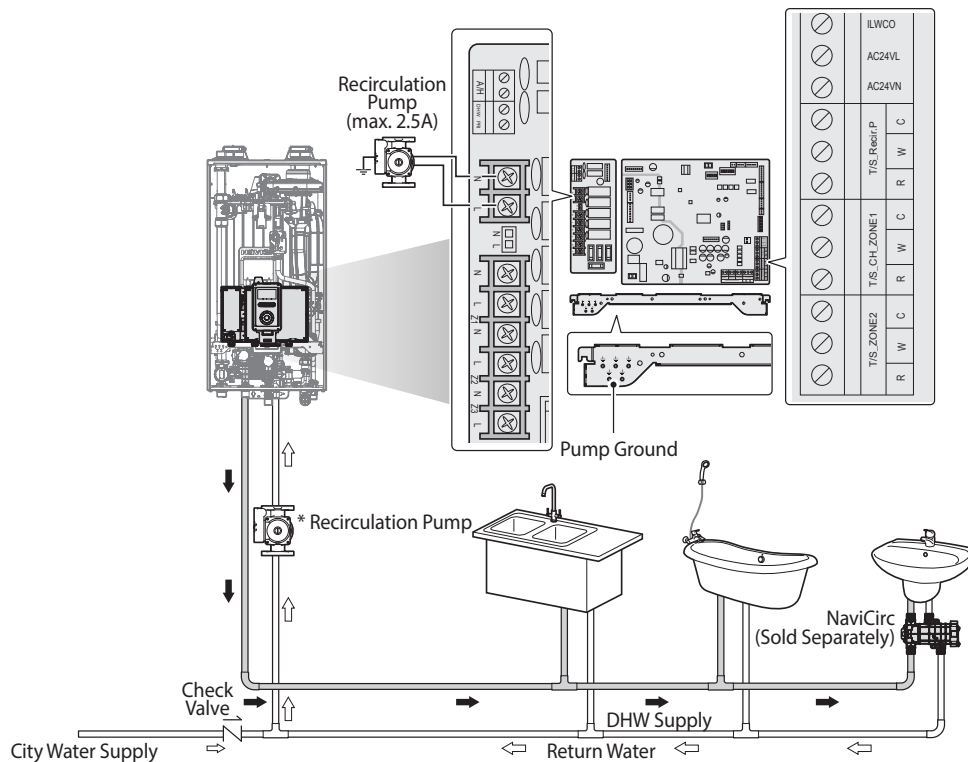

* A Taco 008-BC6 or Grundfos 15-42 BUC7 (or equivalent) circulation pump is recommended for use with the NFC boiler and DHW recirculation systems.

* When using the external recirculation mode, observe the following maximum recirculation pipe lengths including fittings (3/4" pipe is recommended). Lengths in excess of these limits will require a larger recirculation pump.

| Maximum Equivalent Copper Pipe Lengths | | |
|--|---------------|----------------|
| Pipe Diameter | 1/2" | 3/4" |
| Maximum Pipe Length | 100 ft (30 m) | 400 ft (120 m) |

- Note**
- Install the NaviCirc recirculation valve on the faucet furthest from the NFC boiler.
 - If installed in close proximity to the boiler, faucets further down the supply line will take longer to receive hot water.

3.6.7 System Application - External Recirculation with HotButton and NaviCirc

External Recirculation Mode

For best performance, select the manual option in the External recirculation DHW recirculation mode.

Note Combi pre-heat is the default mode for DHW recirculation. To select external recirculation, refer to the combi pre-heat and external recirculation sections in "11.3.4 Setting the DHW Operation" on page 90 for details.

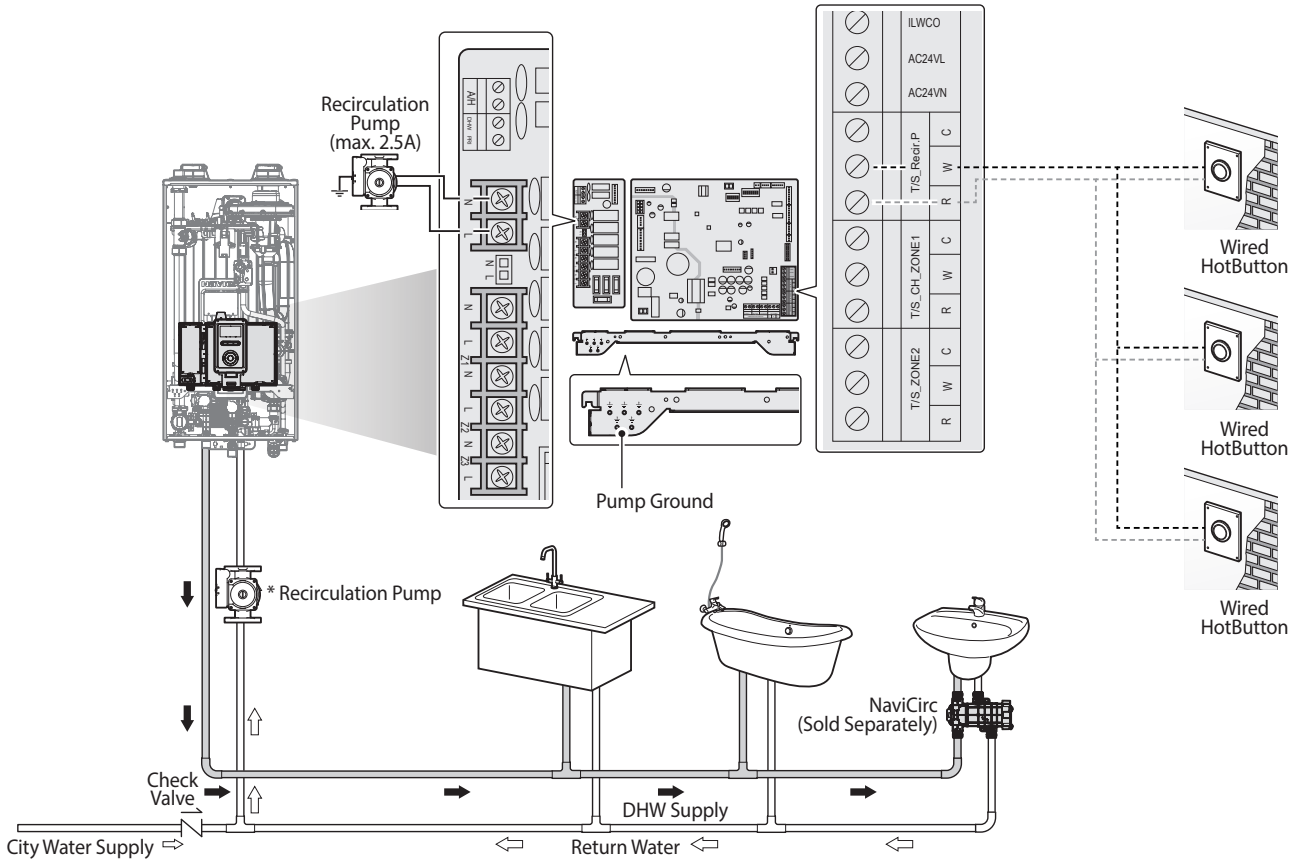

* A Taco 008-BC6 or Grundfos 15-42 BUC7 (or equivalent) circulation pump is recommended for use with the NFC boiler and DHW recirculation systems.

* When using the external recirculation mode, observe the following maximum recirculation pipe lengths including fittings ($\frac{3}{4}$ " pipe is recommended). Lengths in excess of these limits will require a larger recirculation pump.

| Maximum Equivalent Copper Pipe Lengths | | |
|--|-----------------|-----------------|
| Pipe Diameter | $\frac{1}{2}$ " | $\frac{3}{4}$ " |
| Maximum Pipe Length | 100 ft (30 m) | 400 ft (120 m) |

- Note**
- To use HotButton mode, install a HotButton and recirculation pump.
 - Install the NaviCirc recirculation valve to the faucet furthest from the NFC boiler.
 - If installed in close proximity to the boiler, faucets further down the supply line will take longer to receive hot water.

3.6.8 External Recirculation with Dedicated Return Line (Always On, Weekly, Intelligent)

External Recirculation Mode

For best performance, select the intelligent or weekly option in the external recirculation DHW recirculation menu.

Note Combi pre-heat is the default mode for DHW recirculation. To select external recirculation, refer to the combi pre-heat and external recirculation sections in "11.3.4 Setting the DHW Operation" on page 90 for details.

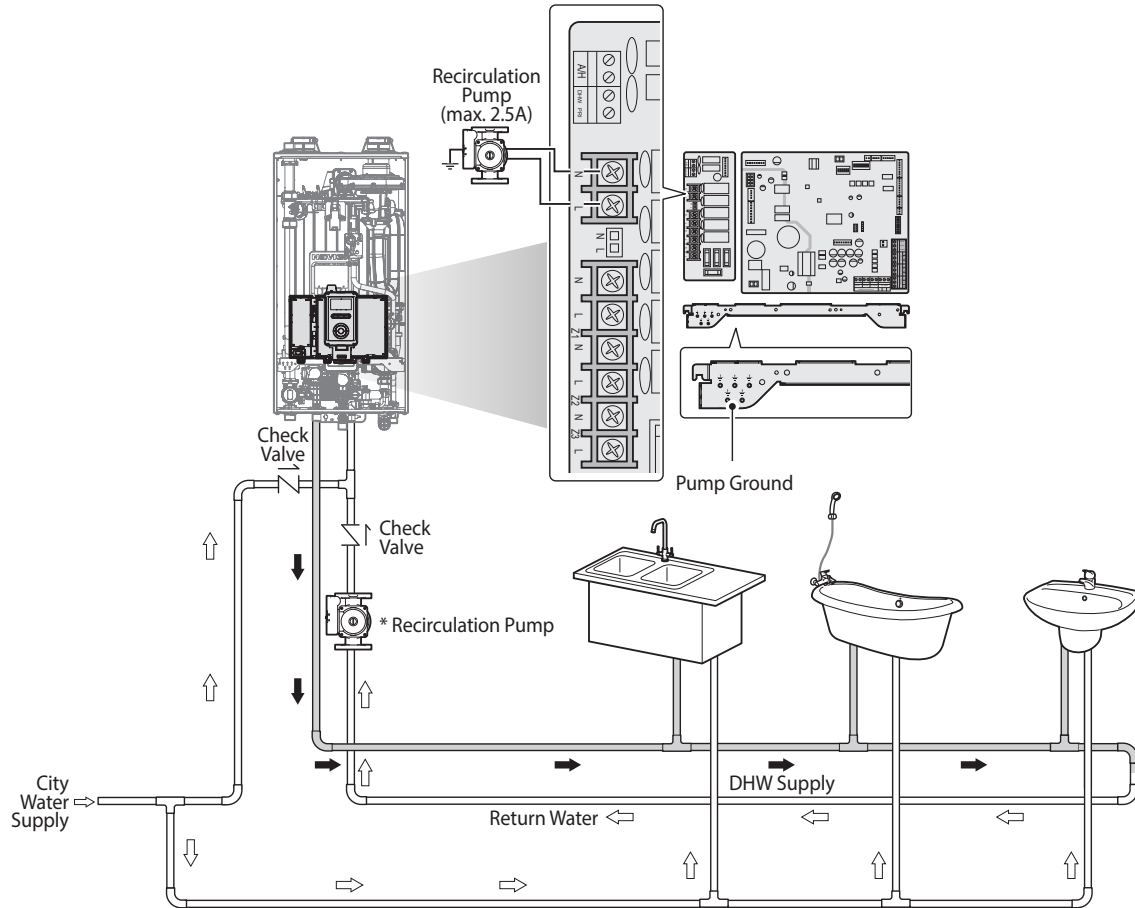

* A Taco 008-BC6 or Grundfos 15-42 BUC7 (or equivalent) circulation pump is recommended for use with the NFC boiler and DHW recirculation systems.

* When using the external recirculation mode, observe the following maximum recirculation pipe lengths including fittings ($\frac{3}{4}$ " pipe is recommended). Lengths in excess of these limits will require a larger recirculation pump.

| Maximum Equivalent Copper Pipe Lengths | | |
|--|-----------------|-----------------|
| Pipe Diameter | $\frac{1}{2}$ " | $\frac{3}{4}$ " |
| Maximum Pipe Length | 100 ft (30 m) | 400 ft (120 m) |

Note If a dedicated return line is installed for external recirculation, the Always On, Weekly, and Intelligent modes can be used after installing a recirculation pump.

3.6.9 External Recirculation with HotButton and Dedicated Return Line (HotButton, Aquastat)

External Recirculation Mode

To use the aquastat mode, install an aquastat to the DHW pipe line and connect to the CNC6 terminal on the PCB. (Refer to "3.7.4 Wiring Diagram - Zone Pump System with DHW Recirculation" on page 41 for details.)

CAUTION

The aquastat temperature must be set lower than the NFC boiler hot water temperature.

Note Combi pre-heat is the default mode for DHW recirculation. To select external recirculation, refer to the combi pre-heat and external recirculation sections in "11.3.4 Setting the DHW Operation" on page 90 for details.

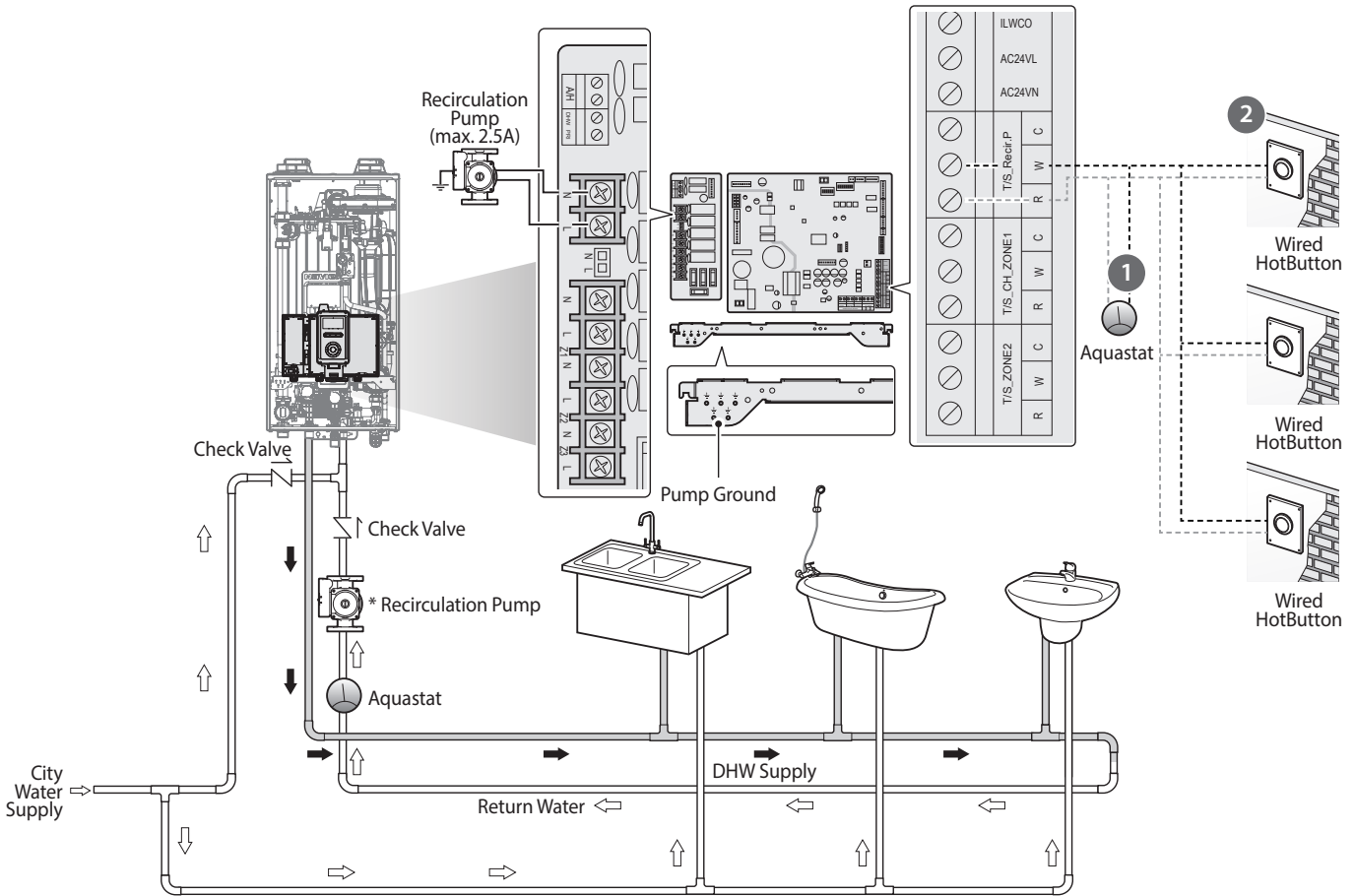

* A Taco 008-BC6 or Grundfos 15-42 BUC7 (or equivalent) circulation pump is recommended for use with the NFC boiler and DHW recirculation systems.

* When using the external recirculation mode, observe the following maximum recirculation pipe lengths including fittings ($\frac{3}{4}$ " pipe is recommended). Lengths in excess of these limits will require a larger recirculation pump.

| Maximum Equivalent Copper Pipe Lengths | | |
|--|-----------------|-----------------|
| Pipe Diameter | $\frac{1}{2}$ " | $\frac{3}{4}$ " |
| Maximum Pipe Length | 100 ft (30 m) | 400 ft (120 m) |

- Note**
- To use HotButton mode, install a HotButton and recirculation pump, but not an aquastat (1).
 - To use Aquastat mode, install an aquastat and recirculation pump, but not a HotButton (2).

3.7 Examples of Electrical Connections

WARNING

Improperly connecting the electrical supplies can result in electrical shock and electrocution. Follow all applicable electrical codes of the local authority having jurisdiction. Connecting the electrical components should be performed only by a licensed professional.

CAUTION

Label all wires before disconnecting them when you work on the controls. Wiring errors can cause abnormal and dangerous operation. Verify proper operation after servicing.

Note The installation must comply with National Electrical Code and any other national, state, provincial or local codes or regulations. In Canada, CSA C22.1 Canadian Electrical Code Part 1, and any local codes. Wiring must be N.E.C. Class 1. If original wiring as supplied with boiler must be replaced, use only type 105 °C wire or equivalent. Boiler must be electrically grounded as required by National Electrical Code ANSI/NFPA 70 – latest edition.

3.7.1 Accessing the Terminal Strips

DANGER

You must ensure that the boiler is disconnected from the electrical supply before carrying out any servicing inside the boiler and, particularly, on the electric terminal strips.

To access the PCB, carefully follow the steps below:

1. Turn off the power supply to the boiler.
2. Unfasten the 4 latches (2 at the top and 2 at the bottom) to remove the front cover and gain access to the internal components.

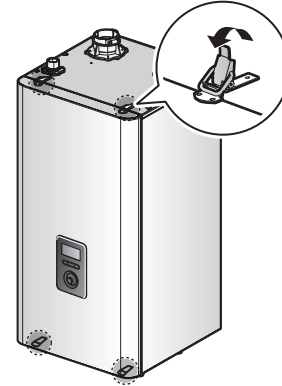

3.7.2 Wiring Diagram - External LWCO

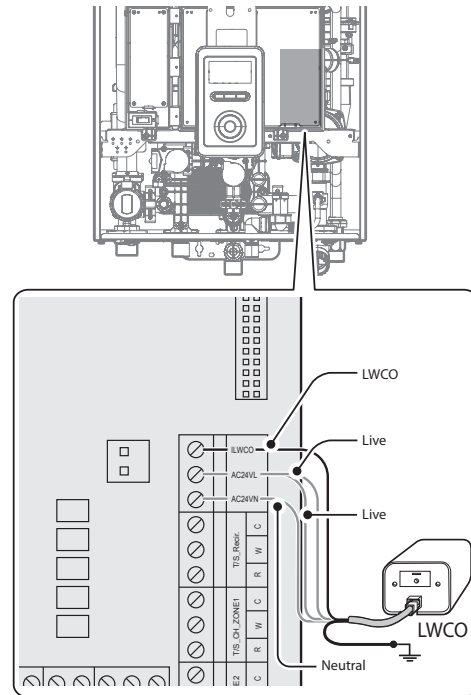

Note The boiler supplies 24 VAC at the LWCO power terminals (CNC3).

For terminal type LWCO appliances, a typical wiring method is shown below (same voltage for control and burner circuit):

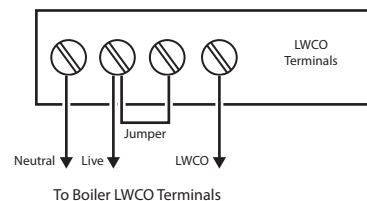

3.7.3 Wiring Diagram - Zone Pump System

NFC boilers can operate a heating system with up to 3 zones. The following is the wiring diagram for a zone pump system with 3 zones.

Without 24VAC Connections

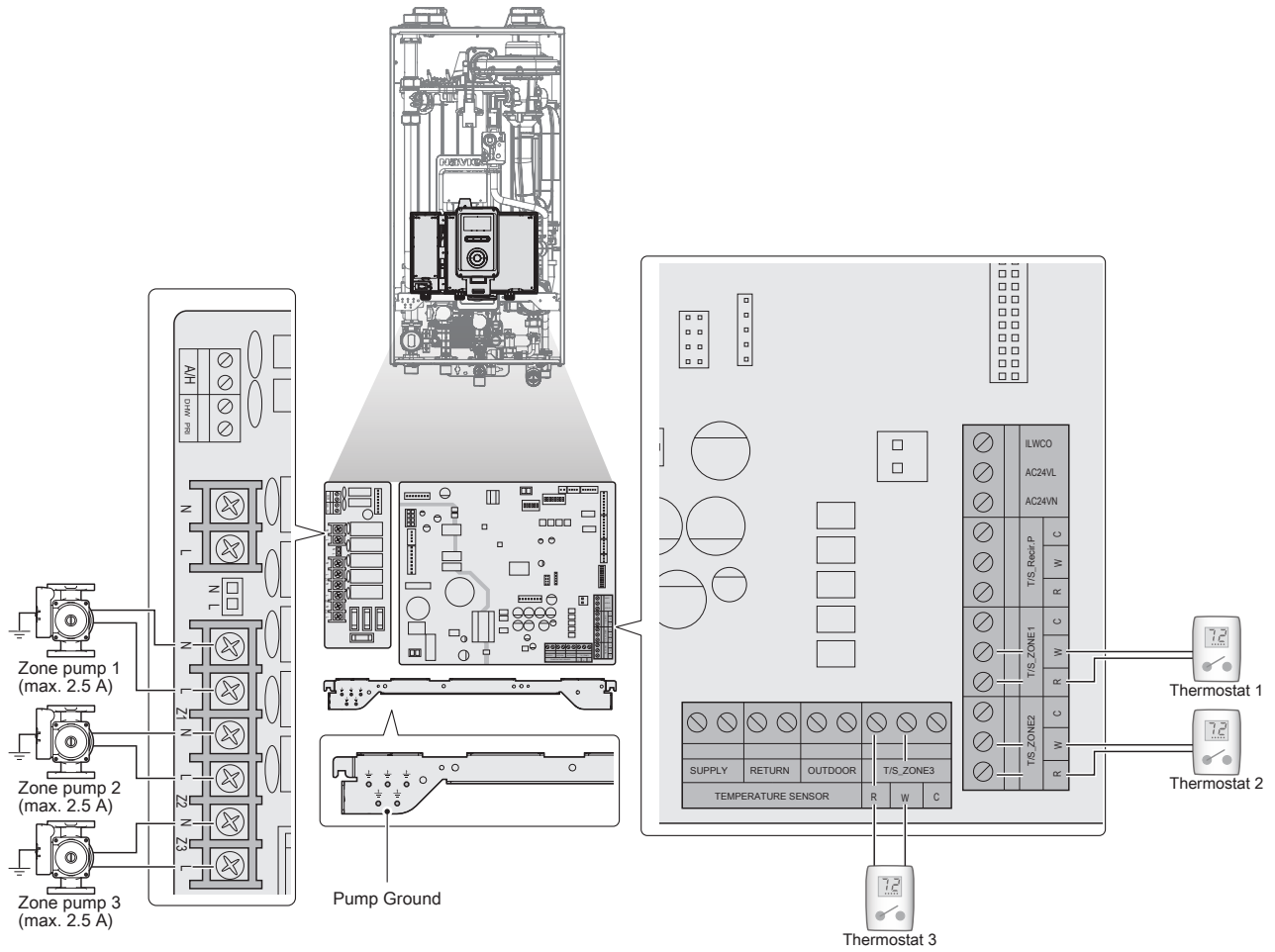

Note

- If you have a 24 V thermostat, connect it to the R & C terminals on the boiler's PCB.
- The C terminals are for optional connections with 24 V thermostat COMMON.

With 24VAC Connections

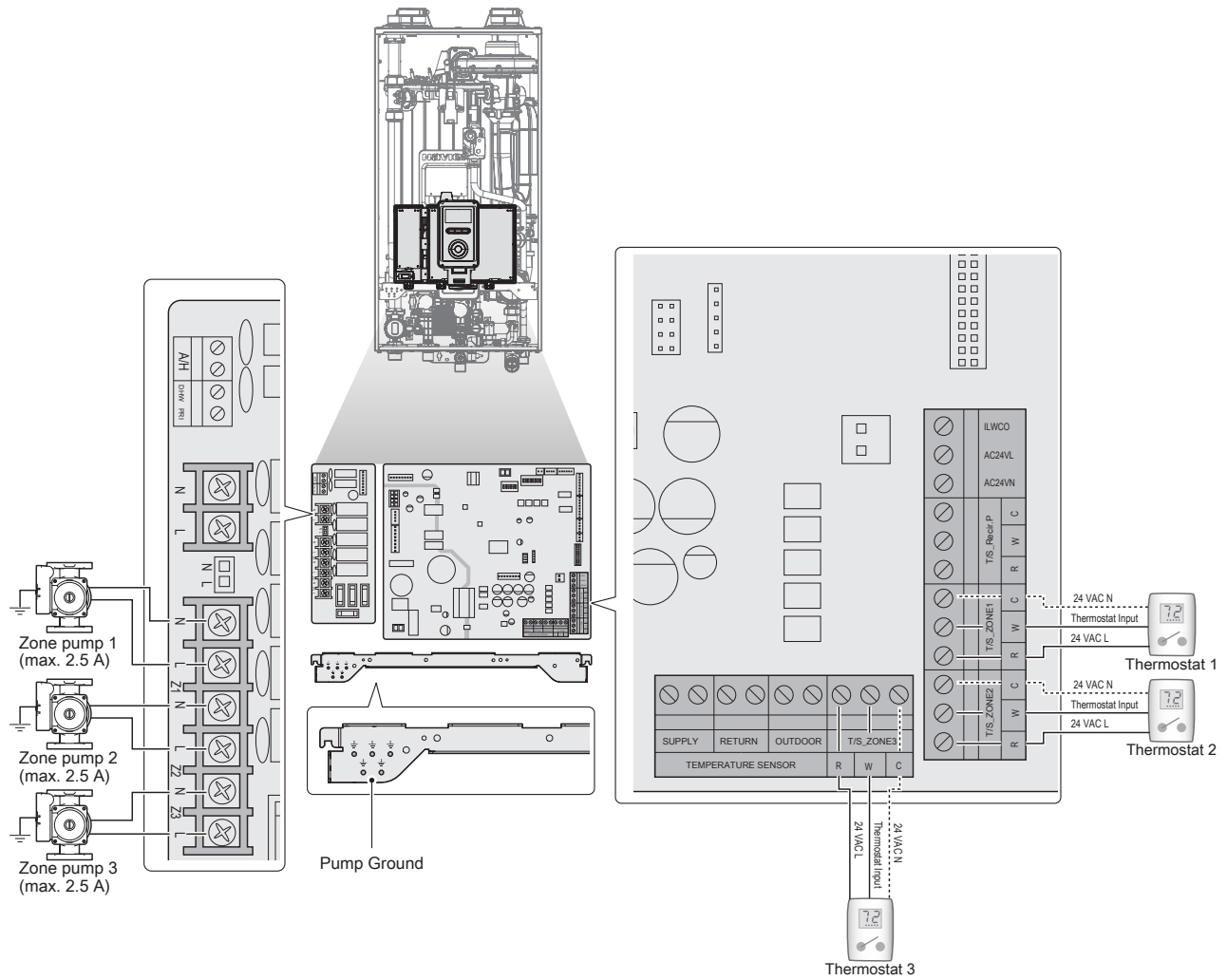

3.7.4 Wiring Diagram - Zone Pump System with DHW Recirculation

NFC boilers can use both the 3 zone heating system and the DHW recirculation feature. The following wiring diagram shows the 3 zone system and the DHW external recirculation feature.

Without 24VAC Connections

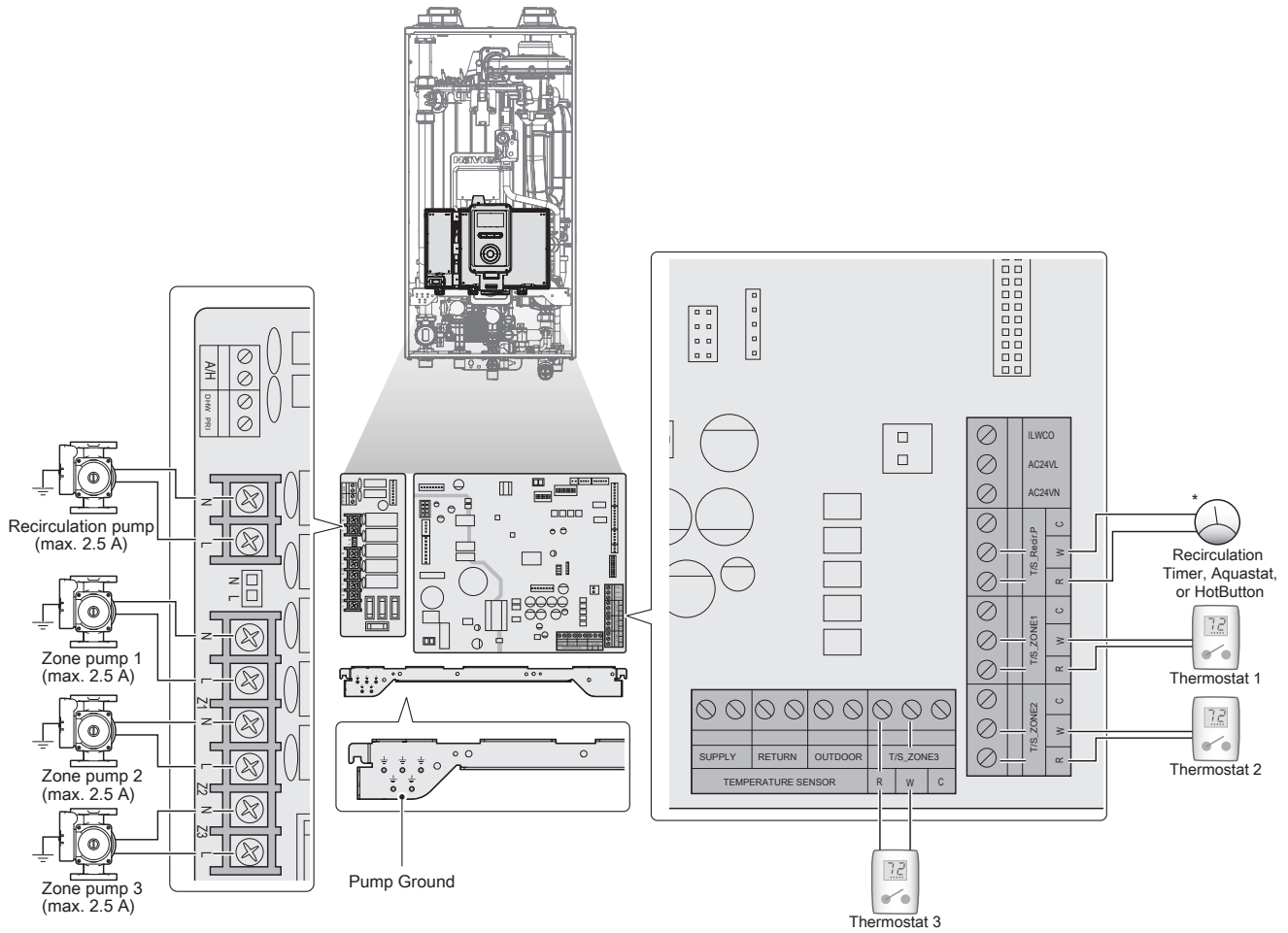

* If the DHW recirculation menu is set to the Always On, Intelligent, or Weekly option, no aquastat or additional HotButton is required.

Note

- The C terminals are for optional connections with 24 V thermostat COMMON.
- When using combi pre-heat, using a recirculation pump is not necessary. Select combi pre-heat on the DHW recirculation menu of the parameter setting part.
- When using external recirculation, install a recirculation pump and select external recirculation in the DHW recirculation menu.

With 24VAC Connections

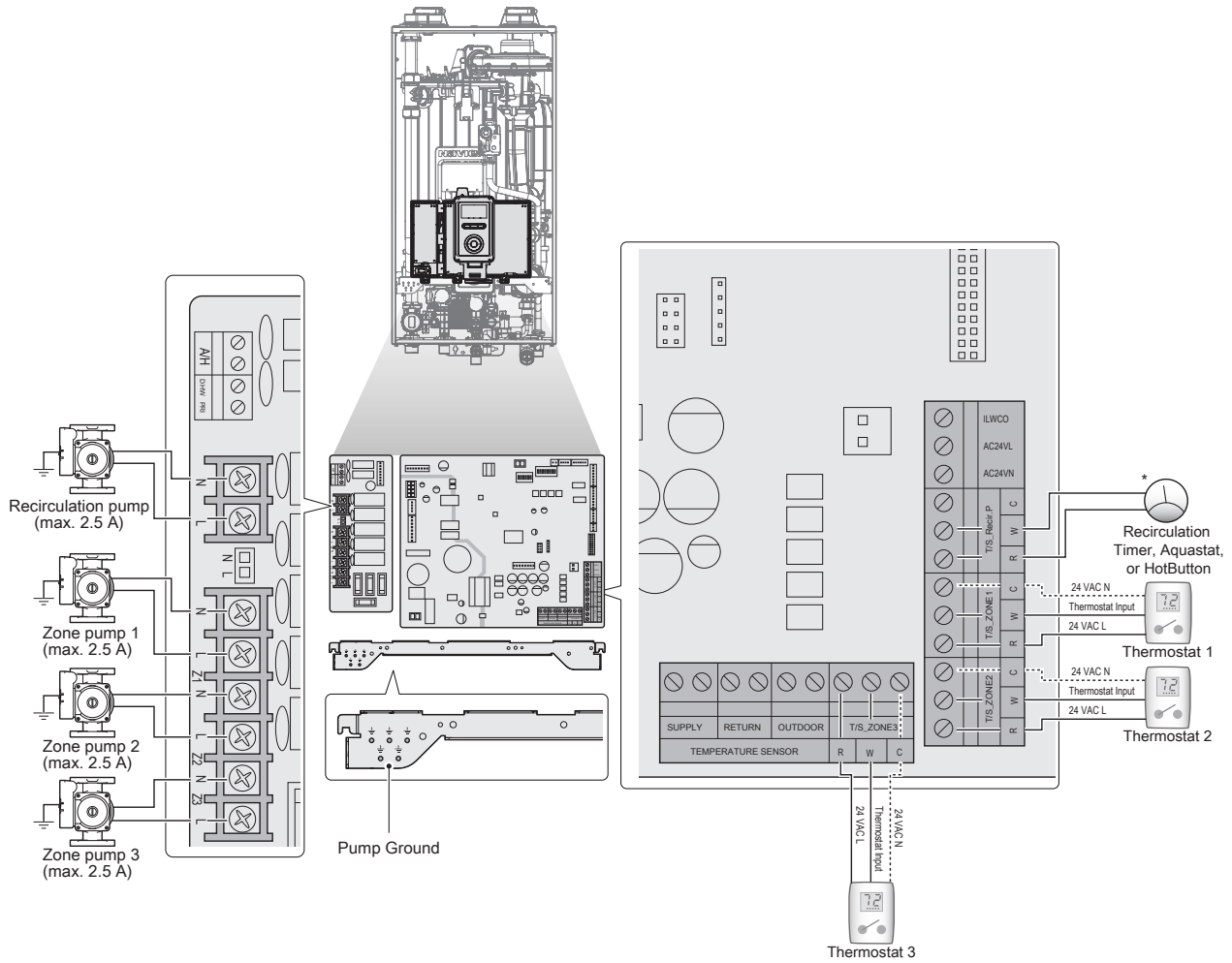

* If the DHW recirculation menu is set to the Always On, Intelligent, or Weekly option, no aquastat or additional HotButton is required.

- Note**
- When using combi pre-heat, using a recirculation pump is not necessary. Select combi pre-heat on the DHW recirculation menu of the parameter setting part.
 - When using external recirculation, install a recirculation pump and select external recirculation in the DHW recirculation menu.

3.7.5 Wiring Diagram - the Navien SmartZone +

The Navien Smart Zone + controller may be used with NFC boilers to operate a heating system with more than 3 zones.

When Navien boilers are used with a Navien Smartzone+ zone pump controller, an RS-485 data communication link is established through the Ready-link connection. This allows the controller and the boiler to share operational information and to control the zones more efficiently by minimizing unnecessary pump operation. The communication link also provides an optimal control environment for freeze protection.

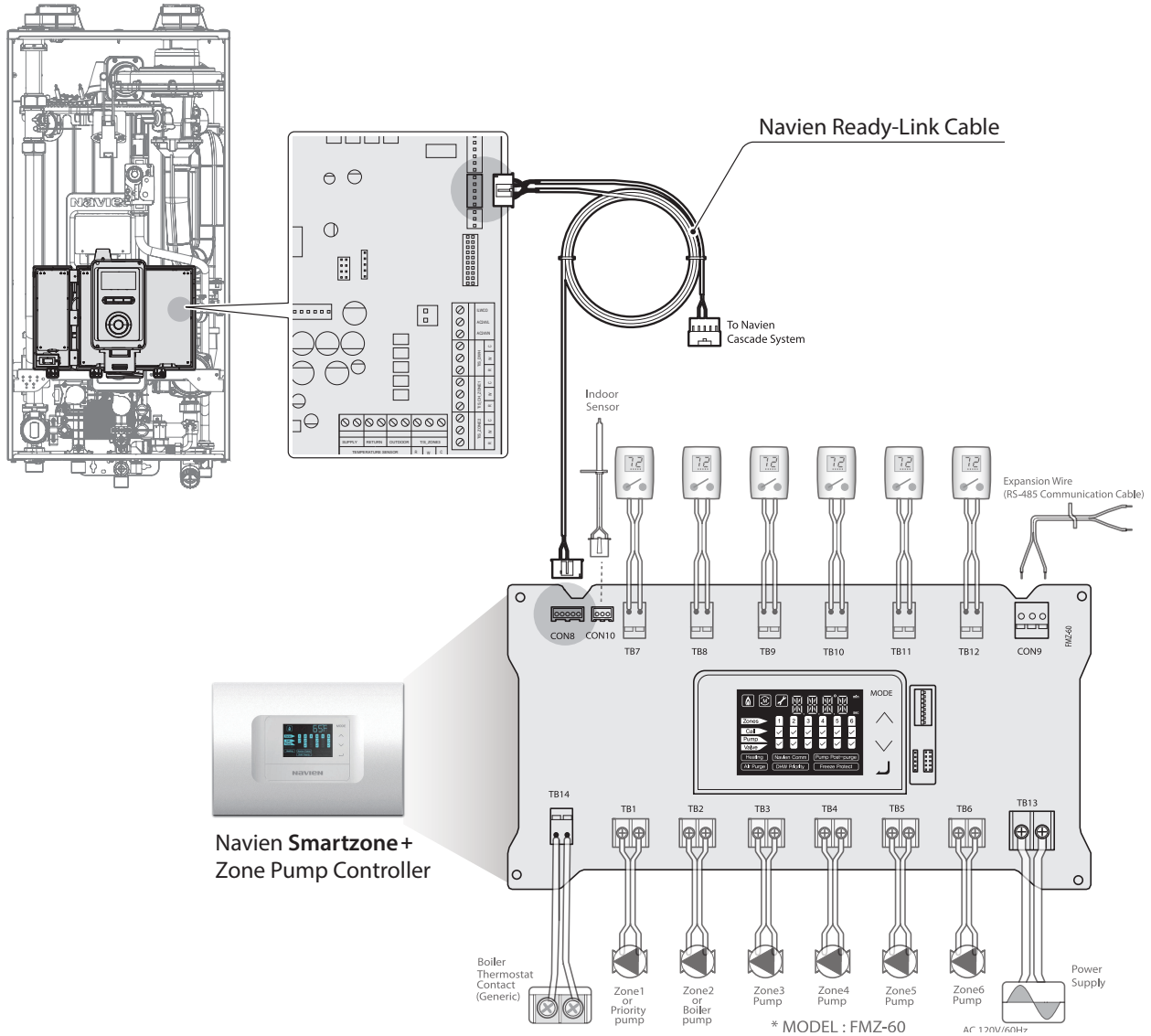

Refer to the user manual that is supplied with the Navien Smartzone+ zone pump controller for details.

Note

The Navien Zone Controller setting must be enabled when using the Ready-Link cable for communication. Refer to "11.3.3 Setting the Space Heating Operation" on page 89 for details.

3.7.6 Wiring Diagram - Generic Zone System with Zone Valves

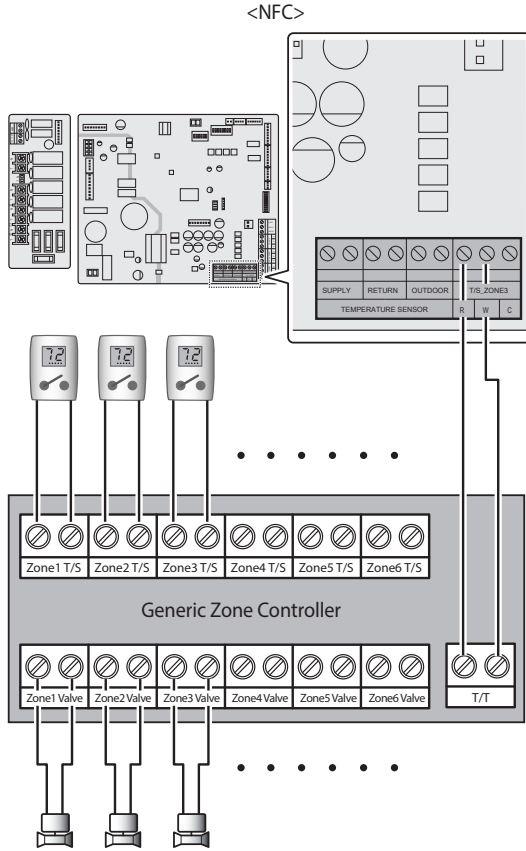

3.7.7 Wiring Diagram - Generic Zone System with Zone Pumps

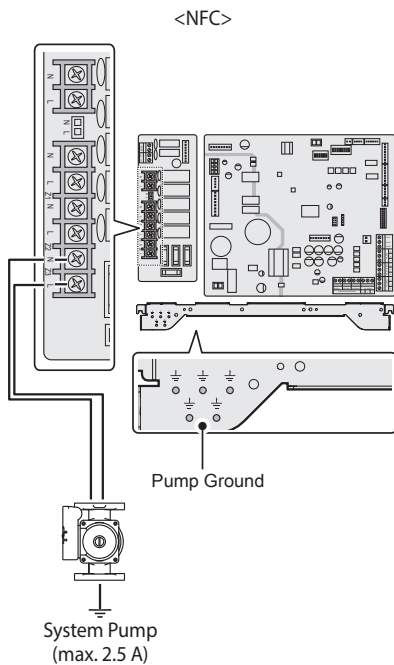
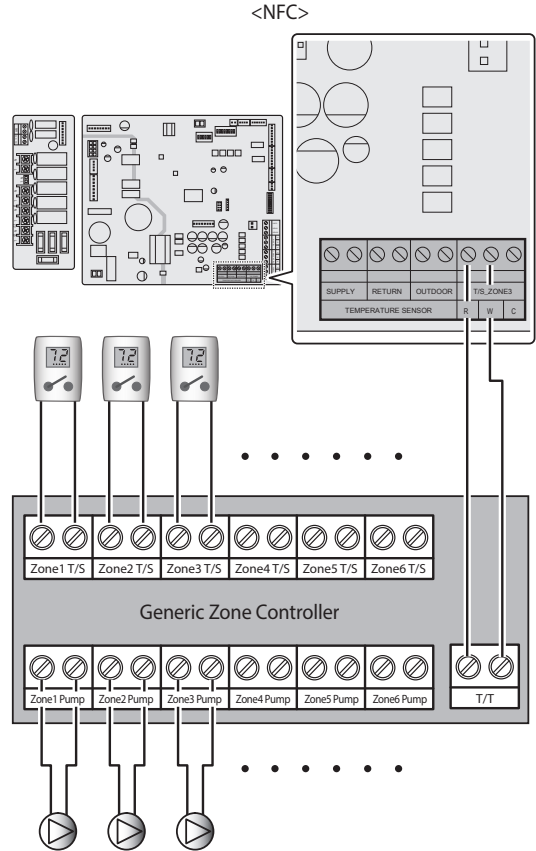

3.7.8 Wiring Diagram - Air Handler

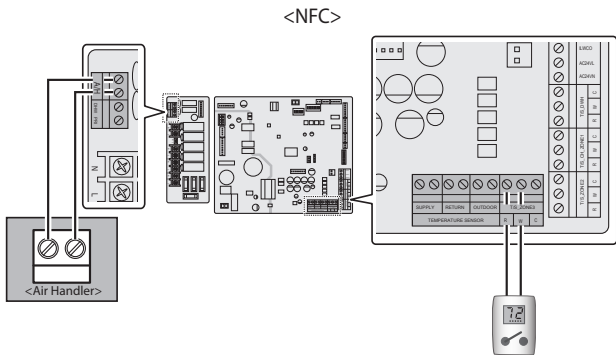

Connect the pump wires to the system pump.

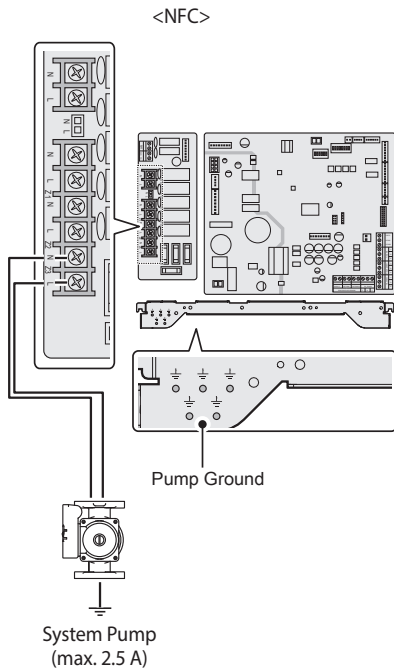

3.7.9 Wiring Diagram - Optional Supply/Return Temperature Sensors

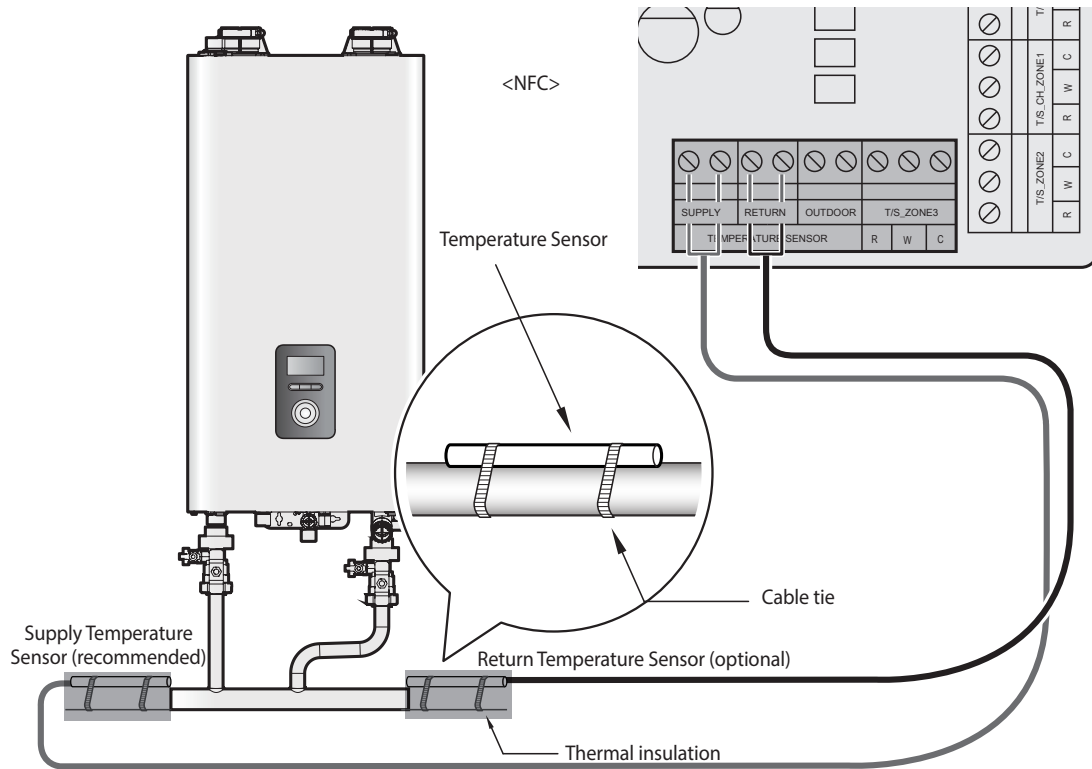

Note

- To control the boiler supply or return water temperature using the external temperature sensor, configure the system accordingly. On the front panel, press the Menu button (**M**) to enter the setting menu, and then select 3. Space Htg Operation > 4. SH Control Method to select one of the control modes.
- For best performance, wrap the sensor and pipe section with thermal insulation.
- A single temperature sensor is supplied with the boiler. Additional temperature sensors are available for purchase. Contact Navien for more information.

4. Connecting the Gas Supply

WARNING

- Before connecting the gas supply, determine the gas type and pressure for the boiler by referring to the rating plate. Use only the same gas type indicated on the rating plate. Using a different gas type will result in abnormal combustion and malfunction of the boiler. Gas supplies should be connected by a licensed professional only.
- The appliance and its gas connection must be leak tested before placing the appliance in operation.
- This boiler cannot be converted from natural gas to propane or vice versa without a Navien gas conversion kit. Do not attempt a field conversion of this boiler without a Navien gas conversion kit. Doing so will result in dangerous operating conditions and will void the warranty.

Navien recommends connecting the boiler as the first appliance downstream of the gas meter, to ensure a sufficient gas supply.

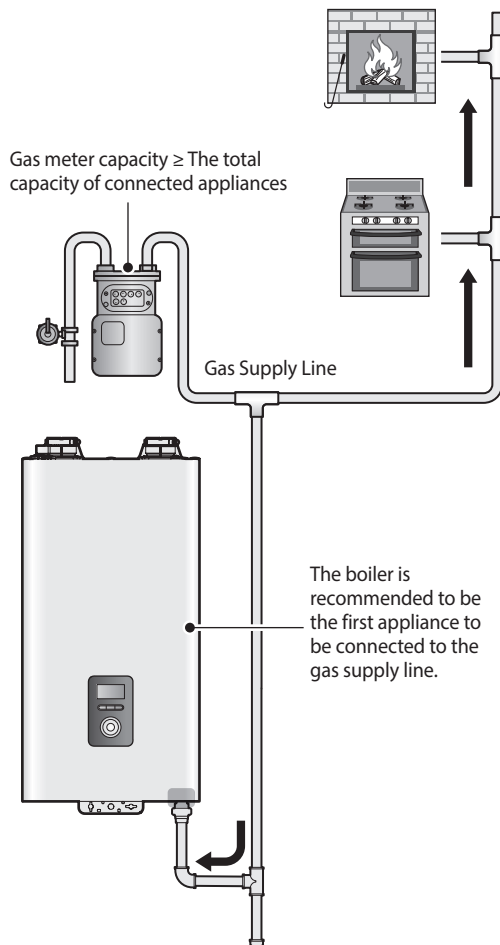

To connect the gas supply:

1. Determine the gas type and pressure for the boiler by referring to the rating plate.
2. Perform a pressure test on the main gas supply line.
3. Purge the gas line of any debris.
4. Determine the proper size and type for the gas line. Refer to the tables that follow.

Note Refer to the instructions provided with the gas regulator for the minimum pipe distance between the regulator and the appliance.

5. Install certified full port valves on the gas supply line and boiler.
6. Connect the gas supply line.
7. Test the supply line, all connection points, and the boiler for gas leaks.

Note Tighten the boiler connection valves with care to avoid damage.

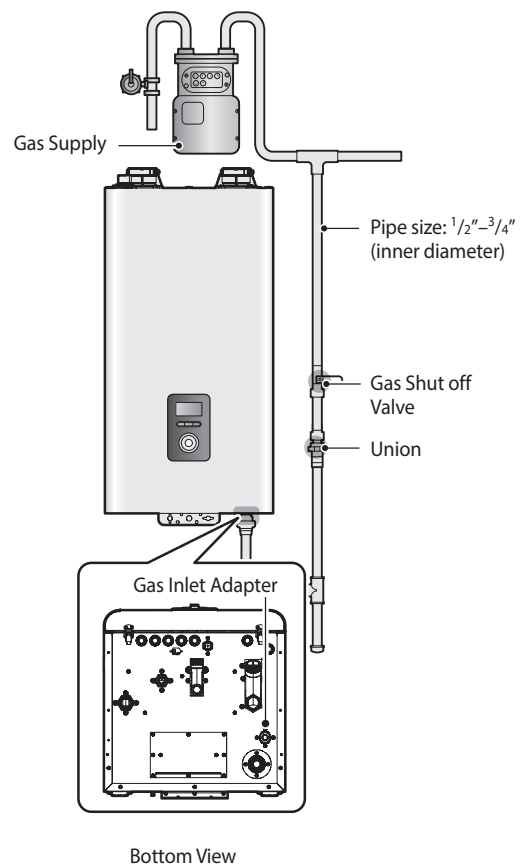

CAUTION

- Install a manual gas shut-off valve between the gas supply line and the boiler.
- A sediment trap must be provided upstream of the gas controls.

Note

- Tighten the boiler connection valves with care to avoid damage.
- The gas connection fitting on all boilers is $\frac{3}{4}$ in.
- $\frac{1}{2}$ in rigid pipe can be used; refer to the sizing tables on the preceding pages for limitations. Do not use $\frac{1}{2}$ in corrugated connectors or tubing as noise may occur.



Corrugated Connector

- When using flexible gas lines, ensure that the pipe's inner diameter and connector is sufficient to supply the required BTUs. Also, ensure that the flexible line has no crimps or tight bends in it, as this will restrict gas flow.
- When using rigid pipe, Navien recommends the installation of a union on the gas supply line close to the boiler, to facilitate any future maintenance or service.
- Check with the local jurisdiction to verify whether the use of $\frac{1}{2}$ " gas pipe is approved in the area.

CAUTION

Prior to using an excess flow valve (EFV) in the gas line, check the manufacturer's minimum and maximum flow capacity rating. An improperly sized EFV will not allow for a full flow of gas to the boiler and may cause improper operation.

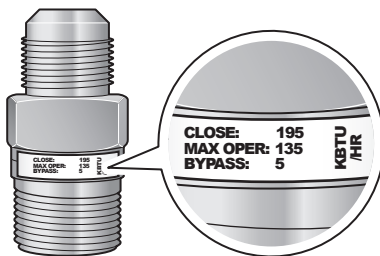

Excess Flow Valve

Typical LP Gas piping examples:

2 Stage System with Multiple Regulators (Recommended)

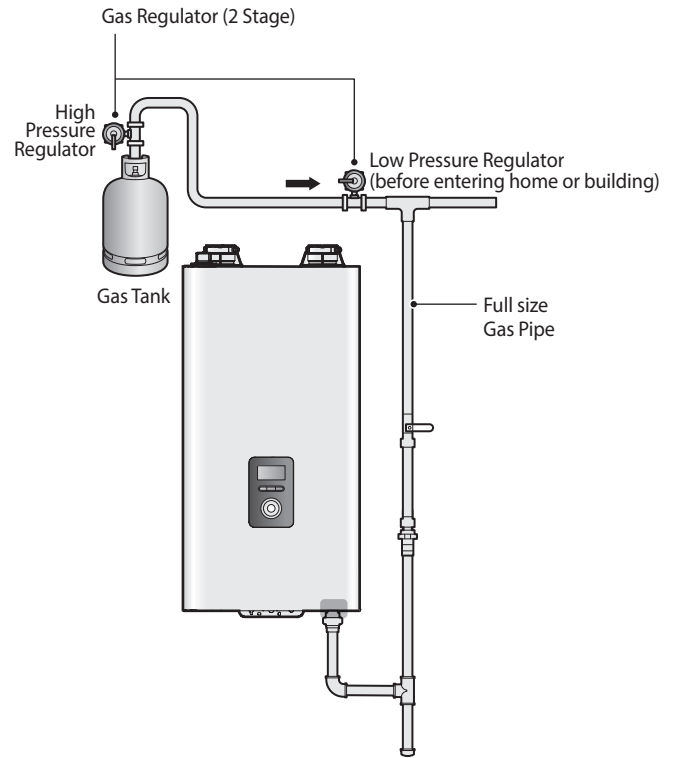

Single Regulator System

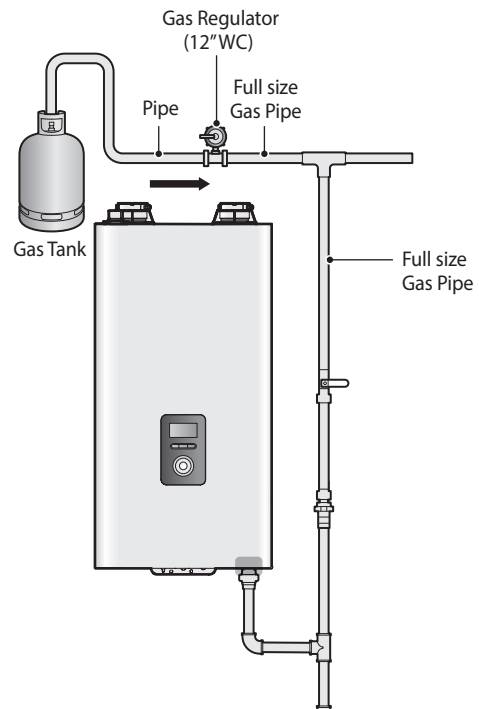

4.1 Gas Pipe Sizing Tables

The following tables are referenced from the 2012 National Fuel Gas Code and are for reference only. Please consult the gas pipe manufacturer for actual pipe capacities.

Maximum Natural Gas Delivery Capacity

In Cubic Feet (ft³) per Hour (0.60 Specific Gravity; 0.5 in WC Pressure Drop). Contact your gas supplier for BTU/ft³ ratings. Use 1,000 BTU/ft³ for simplified calculations. This table is recommended for supply pressures less than 6 in WC.

| Pipe Size | Length (including fittings) | | | | | | | | | | |
|-----------|-----------------------------|----------------|----------------|-----------------|-----------------|-----------------|-----------------|-----------------|-----------------|------------------|------------------|
| | 10 ft (3 m) | 20 ft (6 m) | 30 ft (9 m) | 40 ft (12 m) | 50 ft (15 m) | 60 ft (18 m) | 70 ft (21 m) | 80 ft (24 m) | 90 ft (27 m) | 100 ft (30 m) | 125 ft (38 m) |
| 3/4 in | 360 | 247 | 199 | 170 | 151 | 137 | 126 | 117 | 110 | 104 | 92 |
| 1 in | 678 | 466 | 374 | 320 | 284 | 257 | 237 | 220 | 207 | 195 | 173 |
| 1 1/4 in | 1,390 | 957 | 768 | 657 | 583 | 528 | 486 | 452 | 424 | 400 | 355 |
| 1 1/2 in | 2,090 | 1,430 | 1,150 | 985 | 873 | 791 | 728 | 677 | 635 | 600 | 532 |
| 2 in | 4,020 | 2,760 | 2,220 | 1,900 | 1,680 | 1,520 | 1,400 | 1,300 | 1,220 | 1,160 | 1,020 |
| 2 1/2 in | 6,400 | 4,400 | 3,530 | 3,020 | 2,680 | 2,430 | 2,230 | 2,080 | 1,950 | 1,840 | 1,630 |
| 3 in | 11,300 | 7,780 | 6,250 | 5,350 | 4,740 | 4,290 | 3,950 | 3,670 | 3,450 | 3,260 | 2,890 |
| 4 in | 23,100 | 15,900 | 12,700 | 10,900 | 9,660 | 8,760 | 8,050 | 7,490 | 7,030 | 6,640 | 5,890 |

In Cubic Feet (ft³) per Hour (0.60 Specific Gravity; 3.0 in WC Pressure Drop). Contact your gas supplier for BTU/ft³ ratings. Use 1,000 BTU/ft³ for simplified calculations. This table is recommended for supply pressures of 6 in WC or greater.

| Pipe Size | Length (including fittings) | | | | | | | | | | |
|-----------|-----------------------------|----------------|----------------|-----------------|-----------------|-----------------|-----------------|-----------------|-----------------|------------------|------------------|
| | 10 ft (3 m) | 20 ft (6 m) | 30 ft (9 m) | 40 ft (12 m) | 50 ft (15 m) | 60 ft (18 m) | 70 ft (21 m) | 80 ft (24 m) | 90 ft (27 m) | 100 ft (30 m) | 125 ft (38 m) |
| 1/2 in | 454 | 312 | 250 | 214 | 190 | 172 | 158 | 147 | 138 | 131 | 116 |
| 3/4 in | 949 | 652 | 524 | 448 | 397 | 360 | 331 | 308 | 289 | 273 | 242 |
| 1 in | 1,787 | 1,228 | 986 | 844 | 748 | 678 | 624 | 580 | 544 | 514 | 456 |
| 1 1/4 in | 3,669 | 2,522 | 2,025 | 1,733 | 1,536 | 1,392 | 1,280 | 1,191 | 1,118 | 1,056 | 936 |
| 1 1/2 in | 5,497 | 3,778 | 3,034 | 2,597 | 2,302 | 2,085 | 1,919 | 1,785 | 1,675 | 1,582 | 1,402 |
| 2 in | 10,588 | 7,277 | 5,844 | 5,001 | 4,433 | 4,016 | 3,695 | 3,437 | 3,225 | 3,046 | 2,700 |
| 2 1/2 in | 16,875 | 11,598 | 9,314 | 7,971 | 7,065 | 6,401 | 5,889 | 5,479 | 5,140 | 4,856 | 4,303 |
| 3 in | 29,832 | 20,503 | 16,465 | 14,092 | 12,489 | 11,316 | 10,411 | 9,685 | 9,087 | 8,584 | 7,608 |
| 4 in | 43,678 | 30,020 | 24,107 | 20,632 | 18,286 | 16,569 | 15,243 | 14,181 | 13,305 | 12,568 | 11,139 |

Maximum Liquefied Propane Delivery Capacity

In Thousands of BTU/H (0.5 in WC pressure drop)

| Pipe Size | Length (including fittings) | | | | | | | | | | | | |
|-----------|-----------------------------|----------------|----------------|-----------------|-----------------|-----------------|-----------------|------------------|------------------|------------------|------------------|------------------|------------------|
| | 10 ft (3 m) | 20 ft (6 m) | 30 ft (9 m) | 40 ft (12 m) | 50 ft (15 m) | 60 ft (18 m) | 80 ft (24 m) | 100 ft (30 m) | 125 ft (38 m) | 150 ft (45 m) | 175 ft (53 m) | 200 ft (60 m) | 250 ft (76 m) |
| 1/2 in | 291 | 200 | 160 | 137 | 122 | 110 | 101 | 94 | 89 | 84 | 74 | 67 | 62 |
| 3/4 in | 608 | 418 | 336 | 287 | 255 | 231 | 212 | 197 | 185 | 175 | 155 | 140 | 129 |
| 1 in | 1,150 | 787 | 632 | 541 | 480 | 434 | 400 | 372 | 349 | 330 | 292 | 265 | 243 |
| 1 1/4 in | 2,350 | 1,620 | 1,300 | 1,110 | 985 | 892 | 821 | 763 | 716 | 677 | 600 | 543 | 500 |
| 1 1/2 in | 3,520 | 2,420 | 1,940 | 1,660 | 1,480 | 1,340 | 1,230 | 1,140 | 1,070 | 1,010 | 899 | 814 | 749 |
| 2 in | 6,790 | 4,660 | 3,750 | 3,210 | 2,840 | 2,570 | 2,370 | 2,200 | 2,070 | 1,950 | 1,730 | 1,570 | 1,440 |

4.2 Measuring the Inlet Gas Pressure



WARNING

The boiler cannot function properly without sufficient inlet gas pressure. Measuring the inlet gas pressure should be performed by a licensed professional only.

- The inlet gas pressure must be maintained between 3.5 in and 10.5 in WC for natural gas and between 8.0 in and 13.5 in WC for liquefied propane.
- The appliance and its individual shutoff valve must be disconnected from the gas supply piping system during any pressure testing of that system at test pressures in excess of 1/2 psi (3.5 kPa).
- The appliance must be isolated from the gas supply piping system by closing its individual manual shutoff valve during any pressure testing of the gas supply piping system at test pressures equal to or less than 1/2 psi (3.5 kPa).

To measure the inlet gas pressure:

1. Shut off the manual gas valve on the gas supply line.

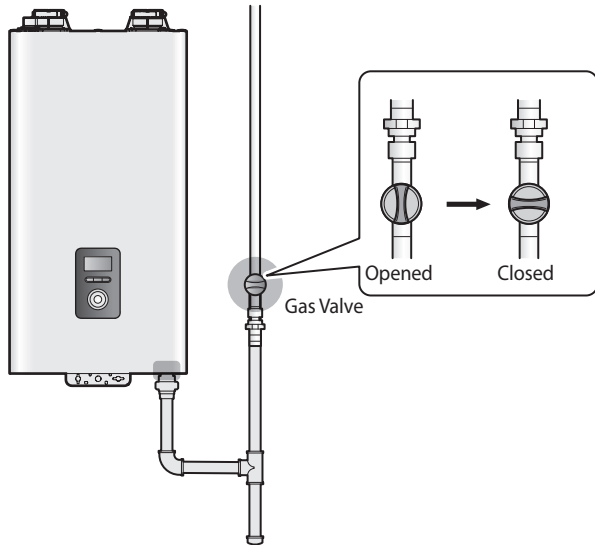

2. Turn on the boiler. On the front panel, press the Back button (↩) and the Menu button (M) simultaneously for 3 seconds, and then rotate the Command dial (⊙) to move to "7. Special Operations".
3. Press the Command dial (⊙) to enter special operation mode.

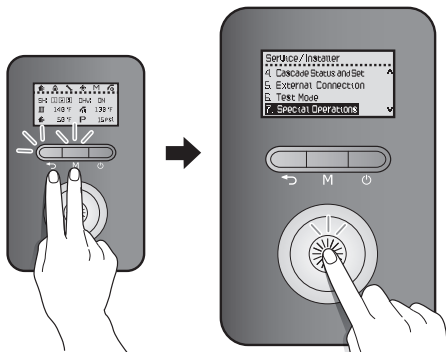

4. Rotate the Command dial (⊙) to move to **7. SH 2nd MAX**, and then press the Command dial (⊙) to select the operation mode.
5. Press the Back button (↩) twice to return to normal operation mode.
6. Run space heating. The gas in the gas supply line will be purged.
7. Leave the boiler on until the boiler shuts down due to a lack of gas supply, and then turn off the boiler.

8. Unfasten the 4 latches (2 at the top and 2 at the bottom) to remove the front cover and gain access to the internal components.

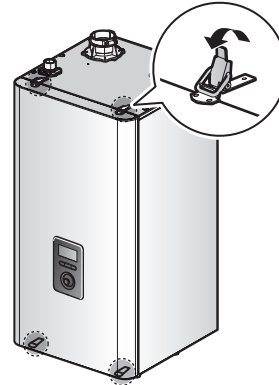

9. Loosen the screws indicated in the figure below and connect a manometer to the pressure port. Reset the manometer to zero before use.

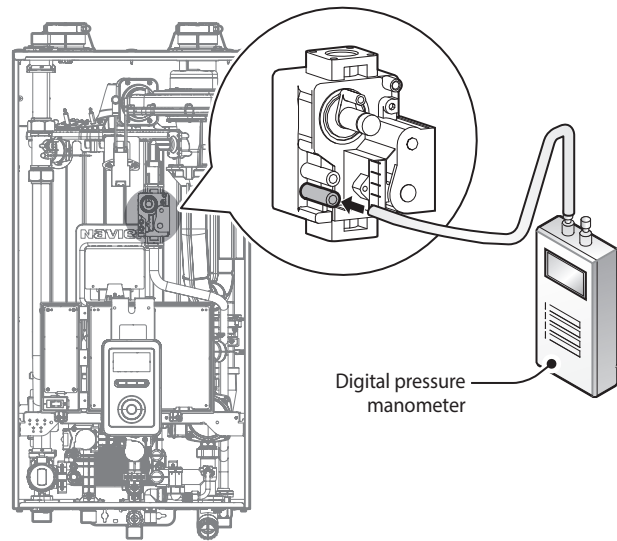

10. Re-open the manual gas valve and check for leaks.
11. Activate multiple zones to ramp the boiler up to its maximum firing rate.
12. When the boiler reaches its maximum firing rate, check the inlet gas pressure reading on the manometer. The gas pressure must fall within the ranges specified on page 10.

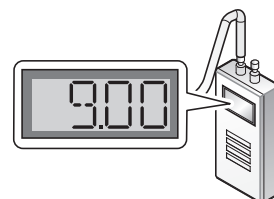

5. Venting the Boiler

WARNING

Improper venting of the boiler can result in excessive levels of carbon monoxide, which can lead to severe personal injury or death. **This boiler must be vented in accordance with the “Venting of Equipment” section of the latest edition of the ANSI Z223.1/NFPA 54 Natural Fuel Gas Code in the USA and/or the “Venting systems and air supply for boilers” section of the latest version of the CAN/CGA B149.1 Natural Gas and Propane Installation Code in Canada, as well as all applicable local building codes and regulations.** Follow all instructions and guidelines when venting the boiler. Venting should be performed only by a licensed professional.

The boiler must be properly vented to ensure a constant supply of clean intake air and to ensure that exhaust air is properly removed from living areas. When venting the boiler, follow these guidelines:

- Do not install the boiler in areas with contaminated air (containing a high level of dust, sawdust, sand, flour, aerosols, or any other such airborne contaminants), as contaminants can cause operational problems. The warranty does not cover damage caused by contaminants in the installation area. If you must install the boiler in an area with contaminated air, use direct venting to supply air from outside the building. We recommend regular filter cleaning and maintenance in these areas.
- For best results, keep the venting system as short and straight as possible.
- Locate the boiler as close as possible to the vent termination.
- Do not connect the boiler vent to a vent for any other gas boiler or vent stack.
- For horizontal runs, slope the horizontal section upward toward the vent termination at a rate of $\frac{1}{4}$ in per foot (2% slope).
- Create an airtight seal at each joint in the exhaust and intake air pipes from the boiler collar to the vent termination.

Connecting the Pipe to the Vent Collar

1. Measure $1\text{--}\frac{3}{4}$ inches from the end of the vent pipe, then draw a mark at that distance.

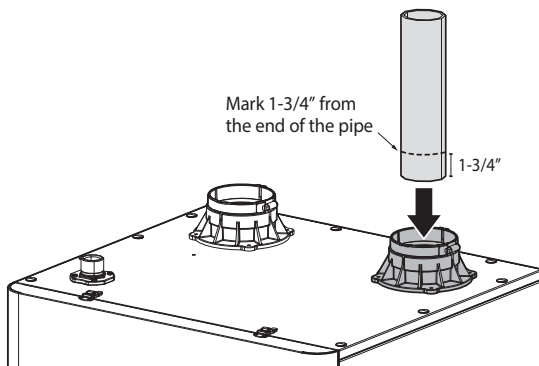

2. Insert the pipe into the vent collar to start the vent run. Make sure to completely slide the vent into the collar until the end makes contact with the bottom of the socket.

Note Verify that $1\text{--}\frac{3}{4}$ " of the pipe has been completely inserted into the collar and that the mark is no longer visible.

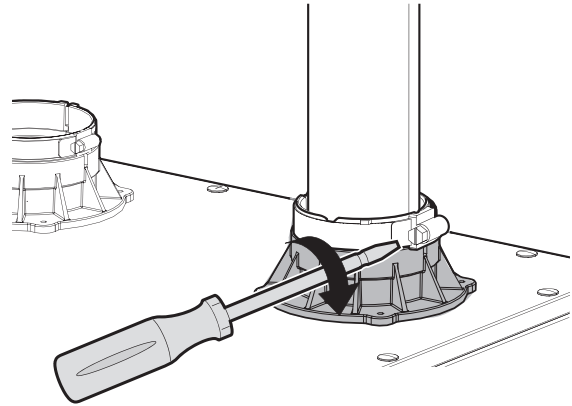

3. Tighten the clamp with a screwdriver to properly seal the joint.

CAUTION

Do not start the vent run with a 90° street elbow at the vent collar. Using an elbow directly at the collar will not allow for a tight seal between the appliance and vent pipe. A length of straight pipe must be used when starting the vent run.

- To avoid moisture and frost build-up and to maintain clearances to openings on adjacent homes, 45° elbows, 90° elbows, or tees may be attached to the end of the termination vent pipe to direct the exhaust plumes away from buildings, as long as the total allowable vent lengths, maximum number of elbows, and distances to air intake restrictions are observed.
- Do not store hazardous or flammable substances near the vent termination.
- If this boiler will be installed in areas where snow is known to accumulate, protect the vent termination from blockage.
- Ensure that the vent termination is at least 12 in (305 mm) above ground, 12 in (305 mm) above the highest anticipated snow level, or as required by local codes, whichever is greater.
- Support the vent pipe with hangers at regular intervals or as required by local codes.
- Exhaust and intake air pipes must be glued and properly supported at least every 4 ft (1.2 m).
- The vent for this appliance shall not terminate over public walkways; or near soffit vents or crawl space vents or where condensate or vapor could create a nuisance or hazard or cause property damage; or where condensate or vapor could cause damage or could be detrimental to the operation of regulators, relief valves, or other equipment.

5.1 Selecting a Vent Type

All boilers are Category IV appliances and prepared at the factory to be direct vented (sealed combustion). Navien recommends direct air vent installations whenever possible to avoid back drafting cold air through the boiler unit. If you cannot use a direct vent, ensure that an ample supply of make-up air is available in the installation location.

Navien also recommends installing a new vent system with this appliance. If reusing an existing vent system, thoroughly inspect it for punctures, cracks, or blockages prior to connecting it to the boiler.

Direct Venting

The boiler uses a 2 in or 3 in diameter exhaust and a 2 in or 3 in diameter air intake ducts. To ensure the draw of air directly from and exhaust of air directly to the outside of the building, create an airtight seal from the boiler collar to the vent termination.

Intake materials can be made of ABS, PVC, CPVC, PP, galvanized or stainless steel, corrugated aluminum or any other such materials. If you use a corrugated material, ensure that there is not inadvertent crimping of, or damage to, the intake air pipe.

When using direct venting, maintain the following venting clearances, as required by **ANSI Z21.10.3 and the National Fuel Gas Code, ANSI Z223.1/NFPA 54, and CAN/CGA B149.1 Natural Gas and Propane Installation Code:**

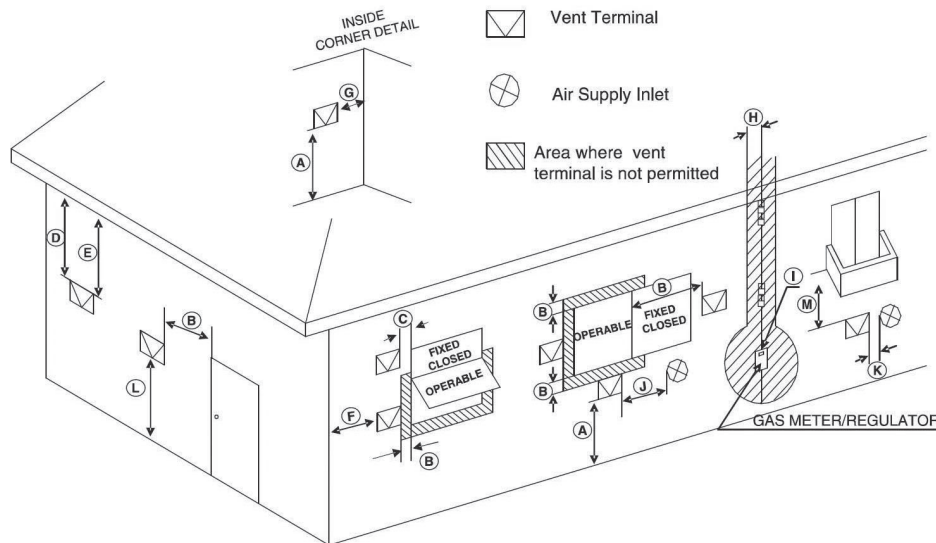

| Ref | Description | Canadian Direct Vent Installations ¹ | US Direct Vent Installations ² |
|-----|--|---|---|
| A | Clearance above grade, veranda, porch, deck, or balcony | 12 in (30 cm) | 12 in (30 cm) |
| B | Clearance to window or door that may be opened | 36 in (91 cm) | 12 in (30 cm) |
| C | Clearance to permanently closed window | * | * |
| D | Vertical clearance to ventilated soffit located above the terminal within a horizontal distance of 2 ft (61 cm) from the center line of the terminal | * | * |
| E | Clearance to unventilated soffit | * | * |
| F | Clearance to outside corner | * | * |
| G | Clearance to inside corner | * | * |
| H | Clearance to each side of center line extended above meter/regulator assembly | 3 ft (91 cm) within a height 15 ft above the meter/regulator assembly | * |
| I | Clearance to service regulator vent outlet | 3 ft (91 cm) | * |

| Ref | Description | Canadian Direct Vent Installations ¹ | US Direct Vent Installations ² |
|-----|--|---|---|
| J | Clearance to nonmechanical air supply inlet to building or the combustion air inlet to any other appliance | 36 in (91 cm) | 12 in (30 cm) |
| K | Clearance to a mechanical air supply inlet | 6 ft (1.83 m) | 3 ft (91 cm) above if within 10 ft (3 m) horizontally |
| L | Clearance above paved sidewalk or paved driveway located on public property | 7 ft (2.13 m) [†] | * |
| M | Clearance under veranda, porch deck, or balcony | 12 in (30 cm) [‡] | * |

¹ In accordance with the current CSA B149.1 Natural Gas and Propane Installation Code

² In accordance with the current ANSI Z223.1/NFPA 54 National Fuel Gas Code

[†] A vent shall not terminate directly above a sidewalk or paved driveway that is located between two single family dwellings and serves both dwellings.

[‡] Permitted only if veranda, porch, deck, or balcony is fully open on a minimum of two sides beneath the floor.

* Clearance in accordance with local installation codes and the requirements of the gas supplier.

Non-Direct Venting (Single Pipe)

If, at any time, the installation location could experience negative pressure, there is a possibility of back drafting cold air through the boiler's heat exchanger. This situation could lead to the freezing of the heat exchanger and malfunction of the boiler.

However, building codes in most jurisdictions disallow negative pressures in residences. In a home with a well-balanced air supply, the heat exchanger should not be in danger of freezing. Because the cause of back drafting is not considered a manufacturing problem, any freezing damage which occurs from back drafting will not be covered by the Navien warranty. If there is any question about the possibility of back drafting in the installation location, use a direct venting system for the boiler.

When using non-direct venting, maintain non-direct vent clearances shown on page 55 as required by **ANSI Z21.10.3 and the National Fuel Gas Code, ANSI Z223.1/NFPA 54, and CAN/CSA B149.1 Natural Gas And Propane Installation Code.**

To use non-direct venting for the boiler:

1. Insert the termination end cap into the intake air duct. Do not glue the end cap, to allow for easy removal and cleaning of the cap.

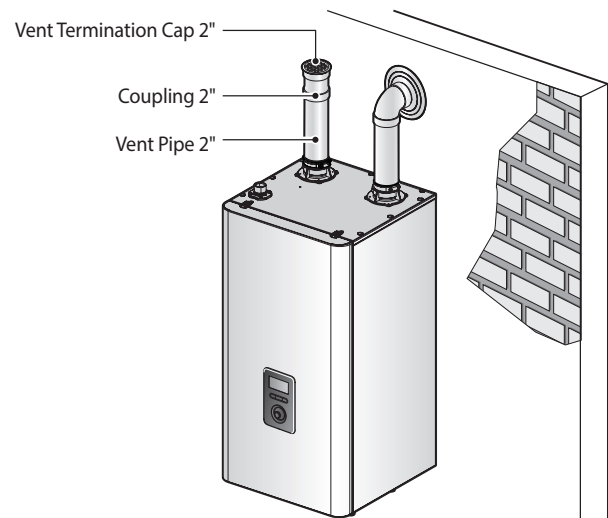

2. Provide two openings to allow for circulation of combustion air as specified by ANSI Z223.1/NFPA 54 or CAN/CGA B-149.1:

| | NFC-175/200 |
|---|---|
| Maximum Input (BTU/H) | 199,900 |
| Outdoor make up air is provided, a minimum free area of 1 in ² , per 4,000 BTU/H | 50 in ² 10 in (W) x 5 in (H) or 8 in round |
| Indoor make up air is provided, a minimum free area of 1 in ² per 1,000 BTU/H | 199 in ² 14 1/4 in (W) x 14 1/4 in (H) |

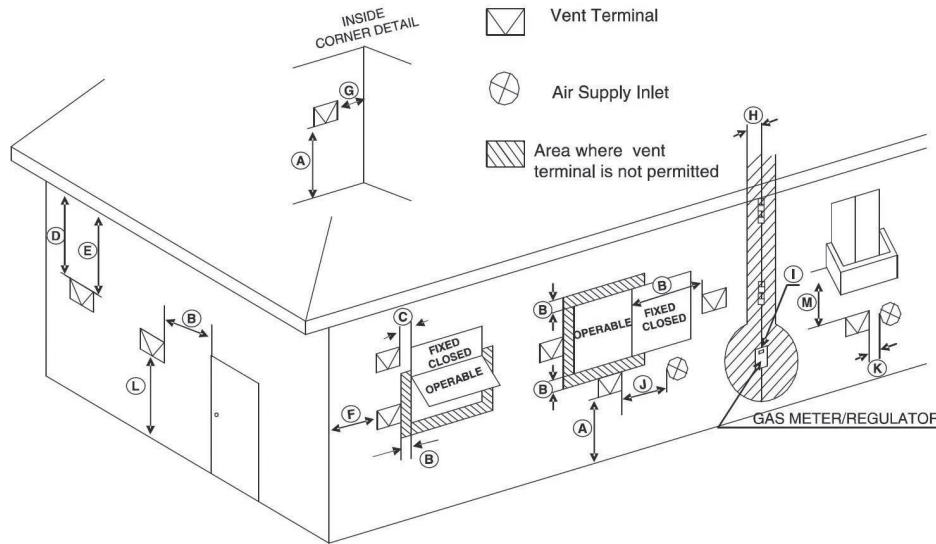

| Ref | Description | Canadian Non-Direct Vent Installations ¹ | US Non-Direct Vent Installations ² |
|-----|--|---|---|
| A | Clearance above grade, veranda, porch, deck, or balcony | 12 in (30 cm) | 12 in (30 cm) |
| B | Clearance to window or door that may be opened | 36 in (91 cm) | 48 in (120 cm) below or to side of opening; 12 in (30 cm) above opening |
| C | Clearance to permanently closed window | * | * |
| D | Vertical clearance to ventilated soffit located above the terminal within a horizontal distance of 2 feet (61 cm) from the center line of the terminal | * | * |
| E | Clearance to unventilated soffit | * | * |
| F | Clearance to outside corner | * | * |
| G | Clearance to inside corner | * | * |
| H | Clearance to each side of center line extended above meter/regulator assembly | 36 in (91 cm) within a height 15 ft (4.57 m) above the meter/regulator assembly | * |
| I | Clearance to service regulator vent outlet | 36 in (91 cm) | * |
| J | Clearance to non-mechanical air supply inlet to building or the combustion air inlet to any other appliance | 36 in (91 cm) | 48 in (120 cm) below or to side of opening; 12 in (30 cm) above opening |
| K | Clearance to a mechanical air supply inlet | 6 ft (1.83 m) | 36 in (91 cm) above if within 10 ft (3 m) horizontally |
| L | Clearance above paved sidewalk or paved driveway located on public property | 7 ft (2.13 m) [†] | * |
| M | Clearance under veranda, porch deck, or balcony | 12 in (30 cm) [‡] | * |

¹ In accordance with the current CSA B149.1 Natural Gas and Propane Installation Code

² In accordance with the current ANSI Z223.1/NFPA 54 National Fuel Gas Code

[†] A vent shall not terminate directly above a sidewalk or paved driveway that is located between two single family dwellings and serves both dwellings.

[‡] Permitted only if veranda, porch, deck, or balcony is fully open on a minimum of two sides beneath the floor.

* Clearance in accordance with local installation codes and the requirements of the gas supplier.

5.2 Selecting Vent Pipe Materials

Venting requirements differ in the US and Canada. Consult the following chart or the most recent edition of ANSI Z223.1/NFPA 54 or CAN/CGA B149.1, as well as all applicable local codes and regulations when selecting vent pipe materials. Do not use cellular core PVC (ASTM F891), cellular core CPVC, or Radel® (polyphenolsulfone) for the exhaust vent.

| Locale | Recommended Vent Materials |
|---------|---|
| USA | <ul style="list-style-type: none"> PVC/CPVC Schedule 40 or 80 (Solid Core) Approved Polypropylene (PP) Approved Stainless Steel (SS) |
| Canada* | <ul style="list-style-type: none"> Type BH Special Gas Vent Class IIA (PVC) Type BH Special Gas Vent Class IIB (CPVC) Type BH Special Gas Vent Class IIC (Polypropylene/Stainless Steel) |

* For installation in Canada, field-supplied plastic vent piping must comply with CAN/CGA B149.1 (latest edition) and be certified to the Standard For Type BH Gas Venting Systems, ULC-S636. Components of this listed system must not be interchanged with other vent systems or unlisted pipes or fittings. All plastic components and specified primers and glues of the certified vent system must be from a single system manufacturer and must not be intermixed with another system manufacturer's parts. The supplied vent connector and vent termination are certified as part of the boiler.

This product is set to use **PVC** as the default vent pipe material. If you require that return water hotter than 140°F (60°C) to circulate back to boiler, the DIP switch must be configured (**Dip Switch 2, switch #8 to ON position**). Otherwise, the boiler will control and maintain the flue and DHW temperature below 150°F (65°C) and 140°F (60°C) respectively.

Note

When you set PCB DIP switch 2 #8 to On, ensure that CPVC, polypropylene or stainless steel piping is used for exhaust venting.

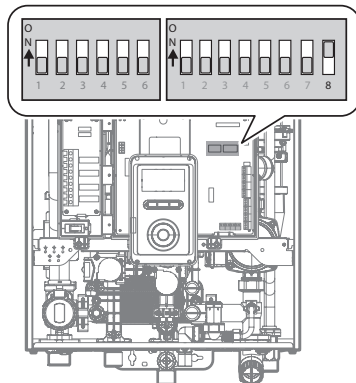

CAUTION

- This boiler has a built-in control to limit the exhaust temperature to 149°F (65°C). As a result, the boiler can be vented with Schedule 40 PVC.
- In high temperature applications, the exhaust temperature can exceed 149°F (65°C). In that case, you must use Schedule 40/80 CPVC or Approved Polypropylene/Stainless Steel in the USA or Type BH Special Gas Vent Class IIB (CPVC) or Class IIC (Polypropylene/SS) that conforms to ULC-S636 in Canada.
- When using 2 in. vent, if the exhaust temperature exceeds 149°F (65°C), CPVC pipe (field supplied) must be used for the first 3 feet of equivalent pipe length. For systems using 3 in. vent, the first 5 in. of length must be CPVC pipe.

The following **polypropylene** vent components are approved for use with this appliance:

Duravent PolyPro® SW (Rigid)
2PPS-xxx (2") or 3PPS-xxx (3")

Centrotherm Innoflue® SW (Rigid)
ISxx02xx (2") or ISxx03xx (3")

Centrotherm Innoflue® (Flexible)
IFVL02xxx (2")
IFSFC02 (2" Rigid-to-Flex Male Adapter)

Hart & Cooley Polyflue™ SW (Rigid)
2PF-xx (2") or 3PF-xx (3")

Z-Flex Z-DENS SW (Rigid)
2ZDP___ (2" or 3")

The following **stainless steel** vent components are approved for use with this appliance:

Duravent FasNSeal® (Rigid)
FSA-PVC3 (3" PVC to FasN Seal Appliance Adapter)
FSxxxxx03 (3")

Heat Fab Saf-T Vent® EZ Seal
9301PVC (3" PVC/CPVC Outlet Boiler Adapter)
93xx (3")

Note

- Only the vent pipe models listed above are approved for use with this appliance.
- Proper appliance adapters must be used when using polypropylene or SS vent pipe.
- Refer to the vent manufacturer's instructions for detailed installation procedures and guidelines.
- Do not use Schedule 40 or 80 polypropylene pipe used for water or waste systems within the vent run.

5.3 Measuring Vent Length

The maximum vent length when using 2 in exhaust ducts is 60 ft (18 m). The maximum vent length when using 3 in vent ducts is 150 ft (45 m). The intake duct length may be identical to the exhaust duct length. Maximum vent lengths reduce according to the number of elbows used, as shown in the following table:

| Vent Size | Maximum Length | Maximum # of Elbows | Equivalent Length |
|-----------|----------------|---------------------|--|
| 2 in | 60 ft (18 m) | 6 | Reduce the maximum vent length accordingly for each elbow used: <ul style="list-style-type: none"> • Each 90° elbow equates to 8 linear feet of vent • Each 45° elbow equates to 4 linear feet of vent |
| 3 in | 150 ft (45 m) | 8 | Reduce the maximum vent length accordingly for each elbow used: <ul style="list-style-type: none"> • Each 90° elbow equates to 5 linear feet of vent • Each 45° elbow equates to 3 linear feet of vent |

Note

- The Maximum Length does not include any elbows.
- The use of a PVC or polypropylene termination kit counts as 5 linear feet (1.5 m) of vent.
- The use of a tee counts for the same equivalent length as a 90° elbow for the vent size.
- The maximum vent lengths at high altitudes are the same as shown in the table above.

5.4 Terminating the Vent

Before installing the boiler, determine what type of vent termination is appropriate for the installation location and materials. The subsections that follow describe some typical venting configurations, but do not include all possible options.

The following **PVC** vent terminations are approved for use with this appliance:

- PVC Concentric Vent Kit (Sch 40 - UL 1738/ULC S636):
 - 2 in Vent Kit
 - 3 in Vent Kit

- IPEX Low Profile Termination Kit:
 - 2 in Low Profile Vent Kit #196984
 - 3 in Low Profile Vent Kit #193985

The following **polypropylene** vent terminations are approved for use:

- Duravent PolyPro Horizontal Concentric Termination Kit
 - 2 in x 4 in Concentric Vent Kit #2PPS-HKL
 - 3 in x 5 in Concentric Vent Kit #3PPS-HKL
- Centrotherm Innoflue Low Profile Termination Kit
 - 2 in Vent Kit #ISLPT0202
 - 3 in Vent Kit #ISLPT0303
- Hart & Cooley Polyflue Horizontal Termination Kit
 - 2 in Vent Kit #2PF-HCT
 - 3 in Vent Kit #3PF-HCT

The following **polypropylene** vent components are approved for use as terminations:

- Duravent PolyPro®**
 2PPS-E90L or 3PPS-E90L (2" or 3" 90° Elbow)
 2PPS-E45L or 3PPS-E45L (2" or 3" 45° Elbow)
 2PPS-TL or 3PPS-TL (2" or 3" Tee)
 2PPS-BG or 3PPS-BG (2" or 3" Birdscreen)

- Centrotherm Innoflue®**
 ISELL0287 or ISELL0387 (2" or 3" 87° Elbow)
 ISELL0245 or ISELL0345 (2" or 3" 45° Elbow)
 IST02 or IST03 (2" or 3" Tee)
 IASPP02 or IASPP03 (2" or 3" Birdscreen)

- Hart & Cooley Polyflue™**
 2PF-90 or 3PF-90 (2" or 3" 90° Elbow)
 2PF-45 or 3PF-45 (2" or 3" 45° Elbow)
 2PF-T or 3PF-T (2" or 3" Tee)
 2PF-HVST or 3PF-HVST (2" or 3" Birdscreen)

The following **stainless steel** (AL29-4C) vent components are approved for use as terminations:

- Duravent FasNSeal®**
 FSELB9003 (3" 90° Elbow)
 FSELB8803 (3" 88° Elbow)
 FSELB4503 (3" 45° Elbow)
 FST3 (3" Tee)
 FSB53 (3" Birdscreen)

- Heat Fab Saf-T Vent® EZ Seal**
 9314(LR) or 9314TERM (3" 90° Elbow)
 9311 (3" 45° Elbow)
 9390TEE (3" Tee)
 9392 (3" Birdscreen)

Note

- Only the termination models listed above are approved for use with this appliance.
- Only terminations of the same manufacturer as the vent system must be used.
- Refer to the vent manufacturer's instructions for detailed installation procedures and guidelines.

Indoor Boiler Installation Venting Examples

The following are some possible indoor venting options:

- Two-Pipe Sidewall Venting

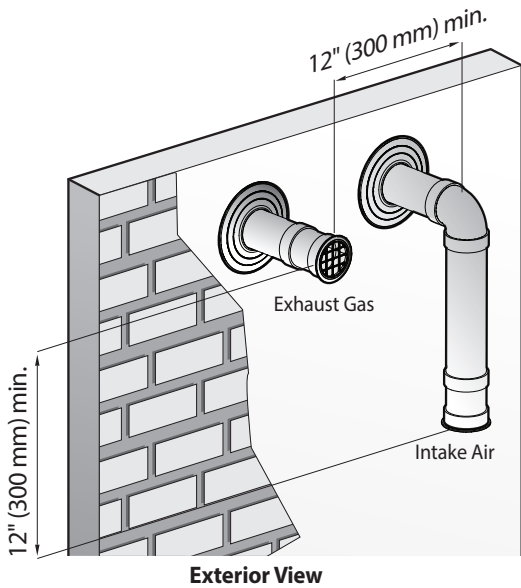
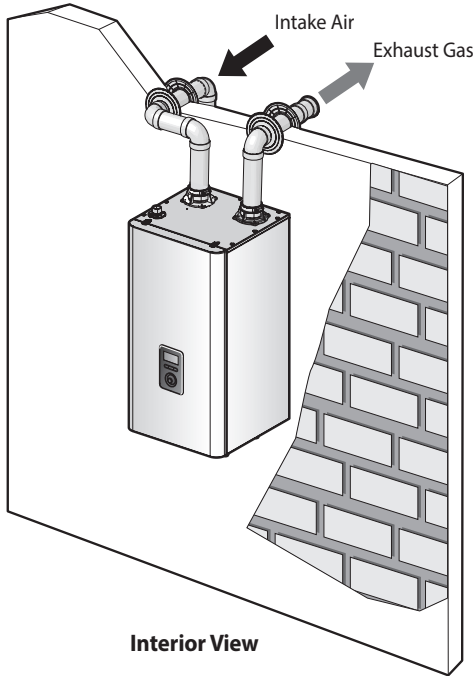

- Non-Concentric Sidewall Venting - Air is drawn from a different location that is at least 12 in (300 mm) away from the exhaust termination. The exhaust termination can be located either on the sidewall or roof. Try to minimize the length of the intake air pipe when installing the vent.

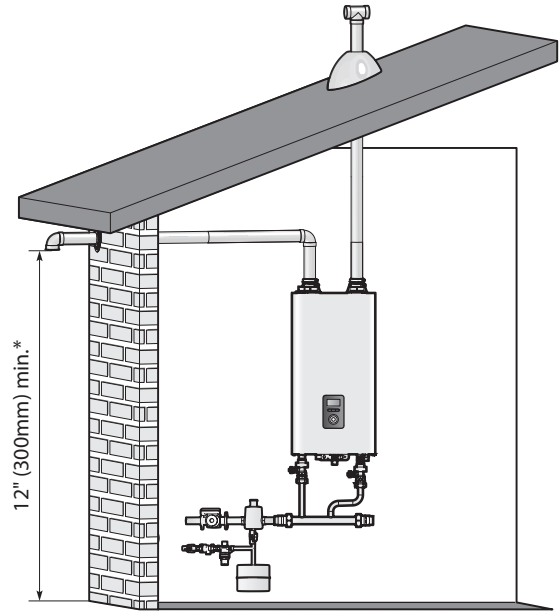

* 12" (300mm) above the highest anticipated snow level, or as required by local codes, whichever is greater

- Concentric Sidewall Venting

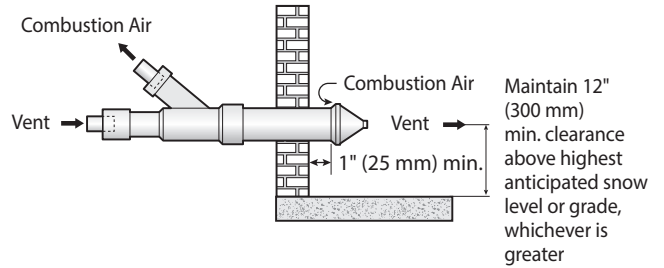

- Concentric Vertical Venting

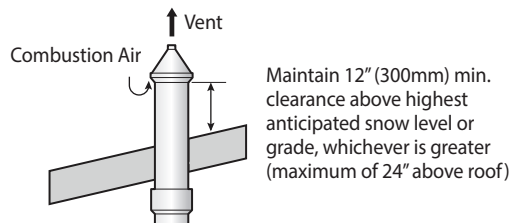

Note For cascade applications, the required horizontal clearance between terminations is 12" for both sidewall and vertical venting installations.



Do not vertically stack concentric terminations on sidewalls.

Indoor Boiler Installation Venting Examples (Continued)

- Low Profile Two-Pipe Sidewall Venting*

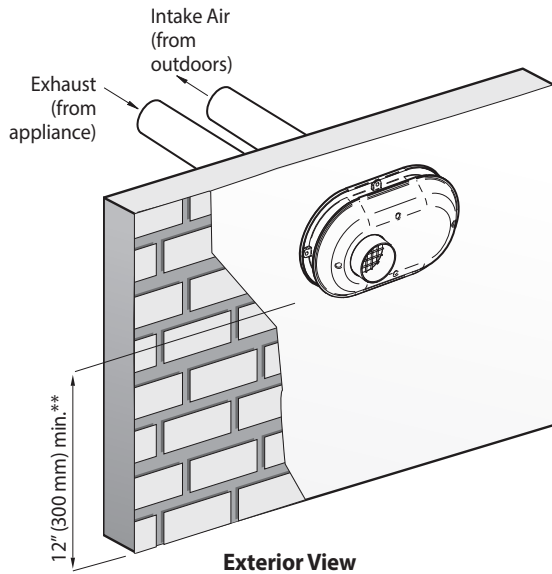

* IPEX and Centrotherm Low Profile terminations only

** Clearance above highest anticipated snow level or grade, or as required by local codes, whichever is greater

Note Only the following orientations are allowed for twin pipe terminations.

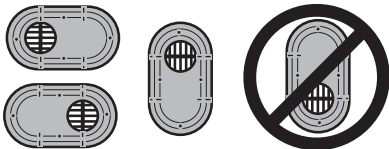

- Flexible Vent Systems (Polypropylene)

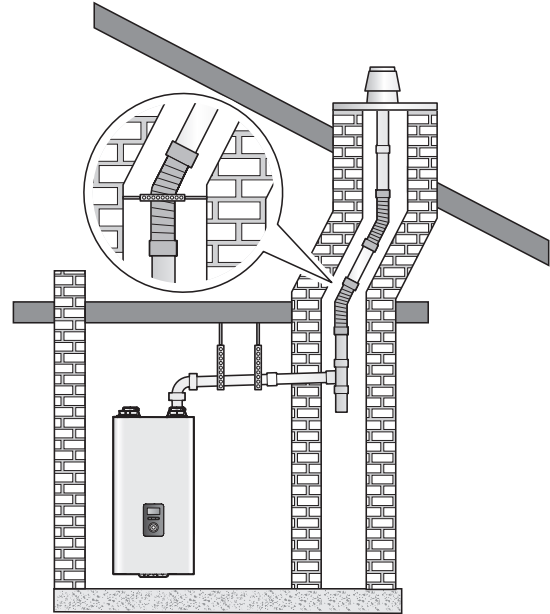

- Note**
- Only VERTICAL installations are allowed. Horizontal terminations are prohibited.
 - The use of proper adapters and supports are required to fully complete the installation.

The following table lists the flexible vent models that are approved for use with this appliance in addition to the maximum allowable vent lengths for the desired vent system.

| Model Type | Vent Dia. | Flexible PP |
|-------------|-----------|---------------------------|
| | | Centrotherm InnoFlue Flex |
| NFC-175/200 | 2 in | 50 ft |

- Only the flexible vent models listed above are approved for use with this appliance.
- All flexible vent pipe must be installed VERTICALLY through the roof. No horizontal terminations are permitted.
- Use a 2 in snap fit coupler or the InnoFlue® Single Wall Residential vent pipes to connect the InnoFlue® Flex 2 in vent pipes to the exhaust.
- After installation, ensure that the vent system is tightly sealed at the joints.
- All installation using the flexible vent materials must be in INDIRECT VENTING only.
- Refer to the manufacturer's literature for detailed information and guidelines.

6. Setting the DIP Switches

CAUTION

Do not remove the front cover unless the power to the boiler is turned off or disconnected. Failure to do so may result in electric shock.

The boiler has 2 sets of DIP switches on the main circuit board (PCB). DIP switches are used to control the functionality of the boiler. Set the DIP switches appropriately, based on the installation environment.

6.1 DIP Switch 1 (6 switch unit)

The DIP SW 1 on the circuit board configures the operation status and model/capacity settings.

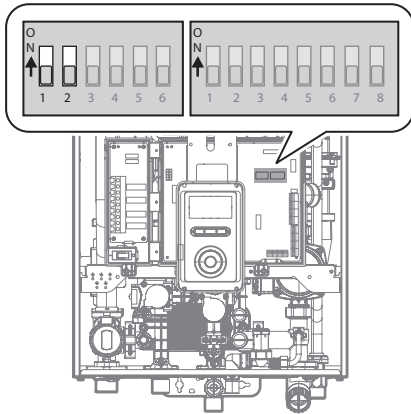

| Switch | Function | Setting | |
|--------|------------------|------------------|--------------|
| 1 & 2 | Operation Status | Normal Operation | 1-OFF, 2-OFF |
| | | 2-stage MAX | 1-ON, 2-OFF |
| | | 1-stage MIN | 1-OFF, 2-ON |
| | | 1-stage MAX | 1-ON, 2-ON |
| 3 & 4 | Reserved | - | - |
| 5 & 6 | Model | NFC-200 | 5-OFF, 6-OFF |
| | | NFC-175 | 5-ON, 6-OFF |

6.2 Dip Switch 2 (8 switch unit)

The DIP SW 2 on the circuit board configures the gas type, temperature control modes, country, and enables or disables the space heating thermostat.

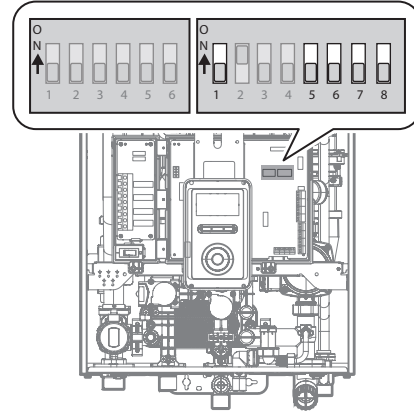

| Switch | Function | Setting | | Comment |
|--------|-----------------------------|---------------------------------|--------------|---|
| 1 | Gas Type | Natural Gas | 1-OFF | Refer to Table 1 in "12.1 Gas & High Altitude Conversion" on page 103 |
| | | Propane Gas | 1-ON | |
| 2 & 3 | High Altitude | 0-1,999 ft (0-609 m) | 2-OFF, 3-OFF | |
| | | 2,000-5,399 ft (610-1,645 m) | 2-ON, 3-OFF | |
| | | 5,400-7,699 ft (1,646-2,346 m) | 2-OFF, 3-ON | |
| | | 7,700-10,100 ft (2,347-3,078 m) | 2-ON, 3-ON | |
| 4 | Well Pump | Used | 4-ON | - |
| | | Unused | 4-OFF | - |
| 5 & 6 | Country | US/Canada | 5-OFF, 6-OFF | - |
| 7 | Space Heating Thermostat | Used | 7-OFF | - |
| | | Unused | 7-ON | - |
| 8 | Exhaust Temperature Control | Used | 8-OFF | - |
| | | Unused | 8-ON | - |

Note

- When PCB DIP switch 2 #8 is set to On, ensure that CPVC, polypropylene, or stainless steel is used for exhaust venting.
- This unit may be installed at elevations up to 10,100 ft (3,078 m) for use with natural gas and propane. To use the unit at a specific altitude, the DIP switches should be set as described above.
- High Altitude: Above 2,000 ft (610 m), the unit will de-rate by 3% for each 1,000 ft (305 m) of altitude gain.
- For NG, if you install the unit at above 5,400 ft (1,646 m), it is required to change the Gas Orifice for high altitude. Be careful not to confuse it with the LP Gas Orifice. Refer to "12.1 Gas & High Altitude Conversion" on page 103 for details.
- Common vent installations for use with natural gas and propane are only approved for up to 4,500 ft.

**CAUTION**

Ensure that the High Altitude setting reflects the actual location of the boiler. If not, it may cause personal injury or malfunction of the boiler.

7. Connecting the Power Supply



WARNING

Improperly connecting the power supply can result in electrical shock and electrocution. Follow all applicable electrical codes of the local authority having jurisdiction. In the absence of such requirements, follow the latest edition of **the National Electrical Code (NFPA 70) in the USA or the latest edition of CSA C22.1 Canadian Electrical Code Part 1 in Canada**. Connecting the power supply should be performed only by a licensed professional.

When connecting the power supply, follow these guidelines:

- Do not connect the electric supply until all water and gas piping is complete and the boiler has been filled with water.
- Do not connect the boiler to a 220-240V AC power supply. Doing so will damage the boiler and void the warranty.
- All the Navien NFC boilers are supplied with a factory-installed, 3-pronged (grounded) plug. The boiler's current rating is 12 A and can be plugged into any grounded electrical outlet adjacent to the boiler. A dedicated power supply is not required.
- If local codes require the boiler to be wired directly, remove and discard the factory-installed plug. Install a power switch between the breaker and the boiler to facilitate end-user maintenance and servicing. Connect the boiler to a 110-120V AC at 60 Hz with a maximum of 15 A.
- The boiler must be electrically grounded. If using the power plug, ensure that the electrical outlet you connect the boiler to is properly grounded. If wiring the boiler directly to a power supply, do not attach the ground wire to gas or water pipes as plastic pipe or dielectric unions may prevent proper grounding.

- We recommend using a surge protector to protect the boiler from power surges.
- If there is a power failure in cold weather areas, the freeze prevention system in the boiler will not operate and may result in the heat exchanger freezing. In cold areas where power failures are common, you must completely drain the boiler to prevent damage if power cuts last for extended periods. A battery back-up (available at most computer retailers) may be used to supply hot water during power outages. Damage caused by freezing is not covered under warranty.



CAUTION

Label all wires before disconnecting them when you work on the controls. Wiring errors can cause improper and dangerous operation. Verify proper operation after servicing.

8. Installing a Cascade System

When installing a cascade system, carefully consider the design of the system and the features of the installation location. Follow all local codes and regulations, as well as all guidelines for installing the combi-boiler and water heaters. The following sections describe additional considerations that are specific to installing cascade systems. Read them carefully before designing or installing the system.

8.1 Connecting Water Supplies

Several options are available for applying a cascade system of combi-boilers and water heaters. The options shown here are only examples. The setup you choose will vary based on the installation location, local building codes, and other factors. Follow all applicable regulations when installing a cascade system.

You can connect up to 1 combi-boiler and 15 Navien water heaters (NPE model) to meet high-volume heating demands. Some possible connection options include the following:

Example of a Basic Cascade System Application

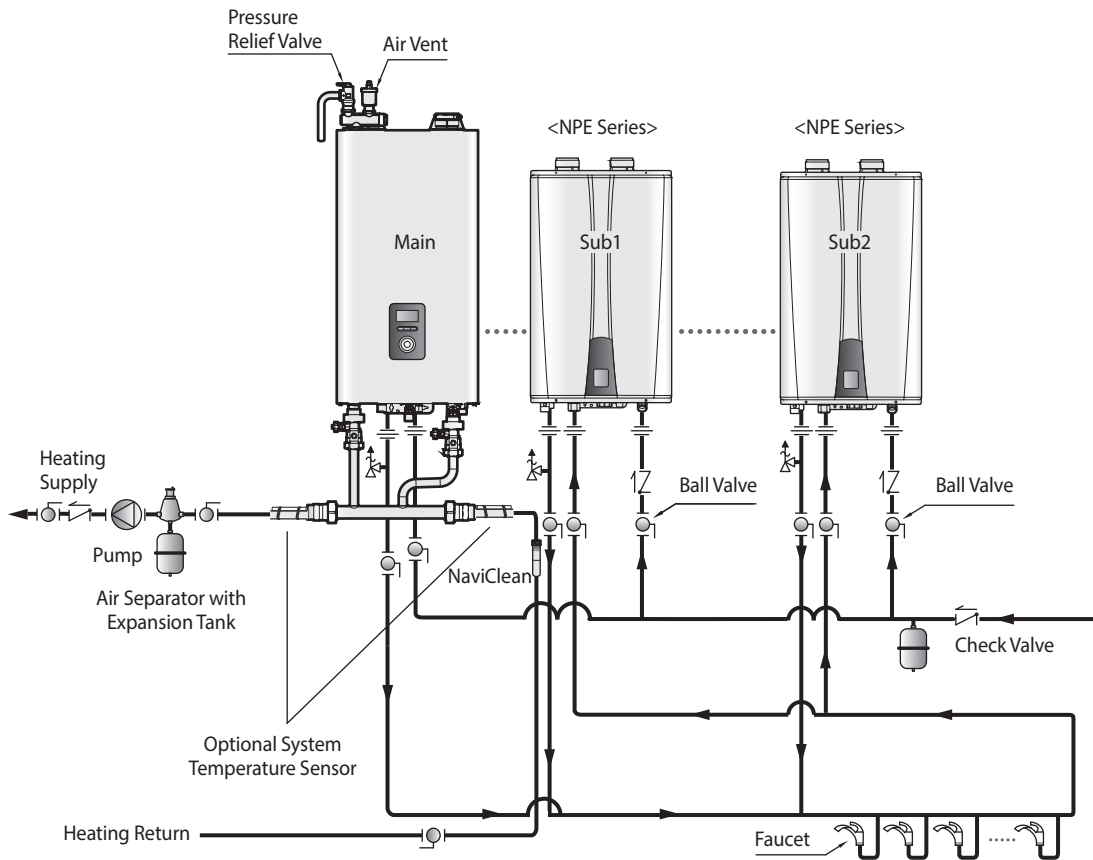

[NFC-175/200]

Note

- System application drawings are intended to explain the system piping concept only.
- Install a NaviClean Filter in the system heating return to remove foreign objects from the system. Foreign objects inside the system may result in abnormal system operation.
- Refer to "3.4 Filling the System" on page 28 for make-up water connections and refer to the requirements of your local codes to ensure compliance.
- Use pumps with integral check valves or install check valves at the pump outlets.
- Adjust the settings at the main unit as the cascade system uses only the main unit settings. Changes made to the sub units are ignored.

- When linking multiple water heaters to NFC combi-boiler, only the master unit can provide space heating and slave units must be configured for DHW only (You can set only the NFC combi-boiler as the master unit in the cascade system, and the master unit controls the power on/off status of all the slave units in the system).
- Once turned on by the master unit, the water heaters will operate in stages to satisfy the DHW demands.
- After completing the cascade settings and saving the changes, the boiler and water heater units must be turned off then turned back on for the changes to take effect.
- If errors occur while operating a cascade system, the relevant errors are displayed in the display of the failing unit.
- Power supply to the units must be OFF during the system piping.

Note

- The recommended recirculation flow rate for each water heater is 2-4 GPM. Depending on the number of water heaters and the diameter of the recirculation line, it may not be necessary to connect all the NPE "A" series water heaters to the recirculation line. If this is the case, set any unconnected "A" model water heaters to Internal Recirculation Mode.
- For any NPE "A" water heater that is connected to the recirculation line, each individual unit must be set to the proper recirculation mode utilizing the 2-way valve and front panel DIP switches. Refer to the NPE Installation Manual for additional details.

8.1.1 Piping Sizes and Considerations

When plumbing a cascading system, consider the following pipe diameters and flow rates. Note that flow rates above 6.6 ft/s may cause pipe erosion. These specifications may vary depending on installation conditions.

Piping Sizes for an NFC Boiler with up to 15 NPE Water Heaters

| Model | | $\Delta T=54^{\circ}\text{F}$ Flow rate (GPM) | Water Velocity (ft/s) | Pipe Diameter (mm/in) | |
|-------------|---------|---|-----------------------|-----------------------|-----------------------------------|
| NFC-175/200 | NPE-240 | | | | |
| 1 | 1 | 14.38 | 5.61 | 25A | 1 in. |
| | 2 | 21.57 | 5.54 | 30A | 1 ¹ / ₄ in. |
| | 3 | 28.77 | 5.21 | 40A | 1 ¹ / ₂ in. |
| | 4 | 35.96 | 6.53 | 40A | 1 ¹ / ₂ in. |
| | 5 | 43.15 | 4.49 | 50A | 2 in. |
| | 6 | 50.34 | 5.24 | 50A | 2 in. |
| | 7 | 57.5 | 6.00 | 50A | 2 in. |
| | 8 | 64.72 | 4.39 | 65A | 2 ¹ / ₂ in. |
| | 9 | 71.92 | 4.75 | 65A | 2 ¹ / ₂ in. |
| | 10 | 79.11 | 5.34 | 65A | 2 ¹ / ₂ in. |
| | 11 | 86.30 | 5.84 | 65A | 2 ¹ / ₂ in. |
| | 12 | 93.49 | 6.33 | 65A | 2 ¹ / ₂ in. |
| | 13 | 100.68 | 6.79 | 65A | 2 ¹ / ₂ in. |
| | 14 | 107.87 | 5.11 | 80A | 3 in. |
| | 15 | 115.07 | 5.44 | 80A | 3 in. |

8.2 Cascade System - Recirculation System Application Example

When using the cascade system, external recirculation can only be connected to and controlled by the NPE "A" water heater. Set each individual water heater to the appropriate recirculation mode utilizing the 2-way valve and front panel DIP switches. Refer to the NPE Installation Manual for additional details.

If Recirculation Return Line Is Installed

Connect the domestic hot water return line to the desired number of NPE "A" water heaters. Set each unconnected NPE "A" water heater to Internal Recirculation Mode. The NFC boiler should be set to Combi Pre-heat Mode.

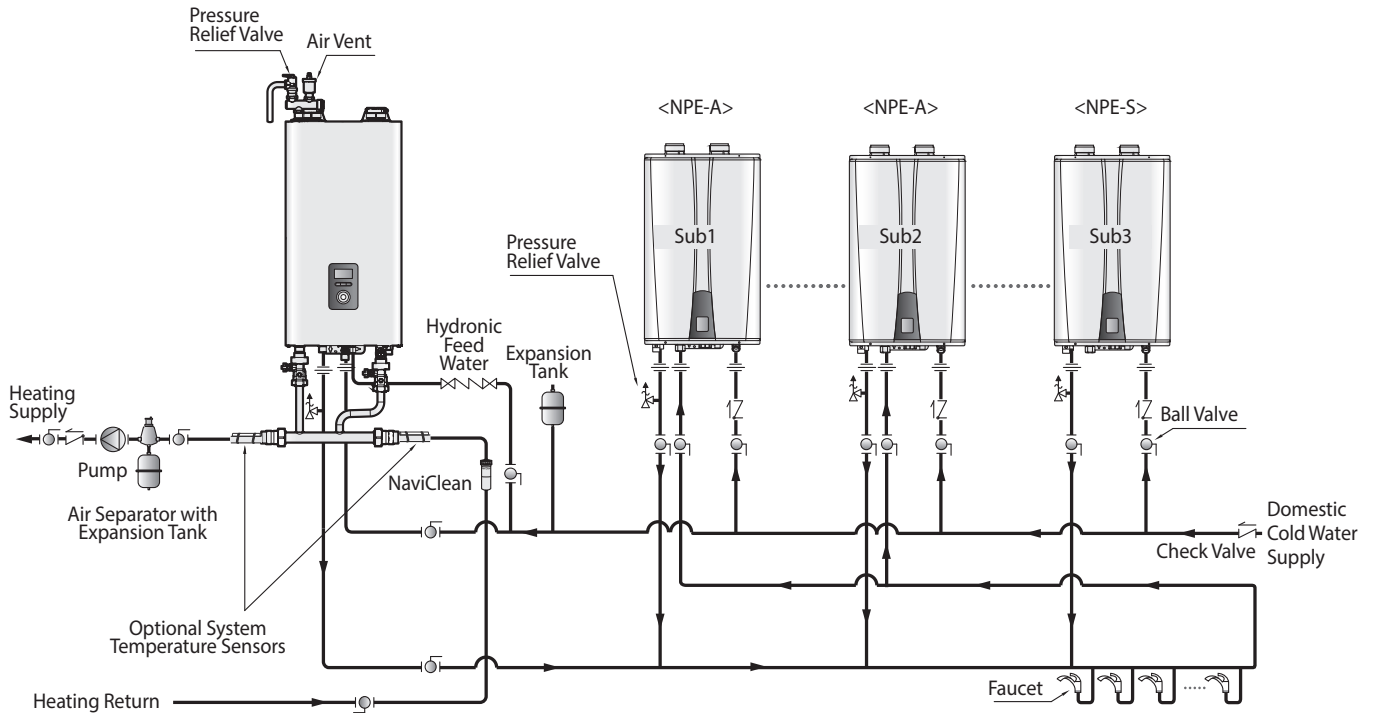

Note A HotButton and Aquastat cannot be used for cascade systems.

If Recirculation Return Line Is Not Installed

Install a NaviCirc valve at the furthest fixture from the water heaters and connect a by-pass line on the 1st NPE "A" unit as illustrated below. Refer to the NaviCirc and NPE Installation Manuals for additional details. The NFC boiler should be set to Combi Pre-heat Mode.

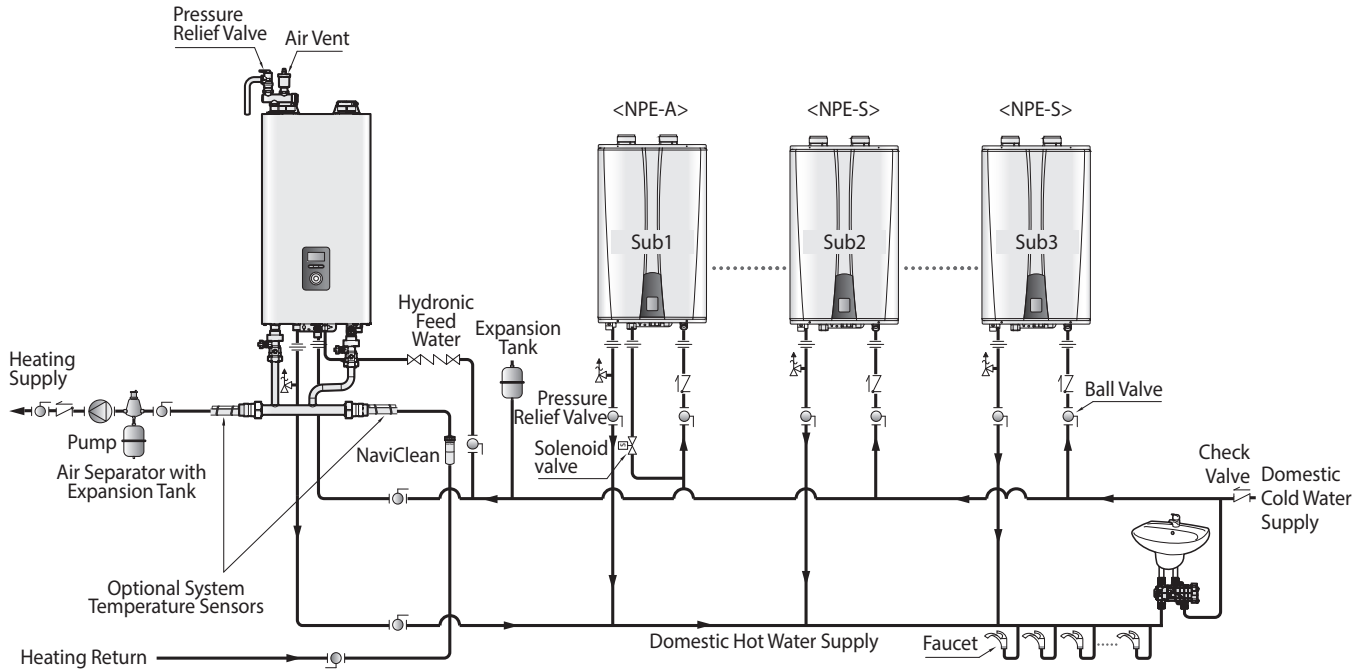

Note A HotButton cannot be used for cascade systems.

8.3 Connecting the Communication Cables

You can connect one NFC boiler with up to 15 Navien water heaters (NPE Model), using the Ready-Link communication cables. Select the NFC series combi-boiler in the cascading system as the main unit, and then connect the water heaters to it as sub units. Before making any connections, ensure that the power is turned off to all the units.

NFC Boiler Connection Method

Connect the Ready-Link cables to the CNK1 terminal strip:

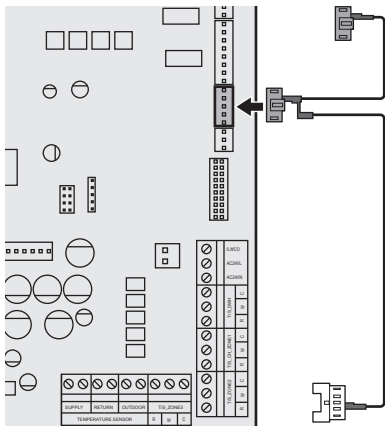

NPE Water Heater Connection Method

Connect the Ready-Link cables to the J6 ports on the right side of the front panel:

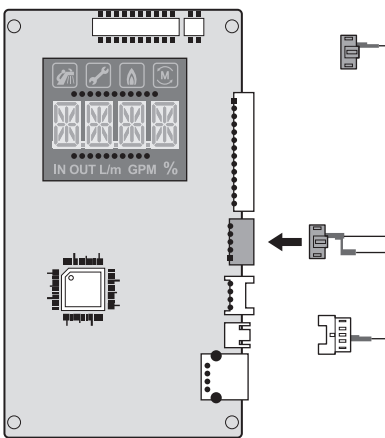

8.3.1 Connecting the Communication

After connecting the Ready-Link communication cables, restore power to the boiler and turn on all boilers using the Power button.

To configure the communication settings:

1. On the main NFC boiler panel, press the Back button (↶) and the Menu button (M) simultaneously for 3 seconds, and then select "4. Cascade Status and Set".

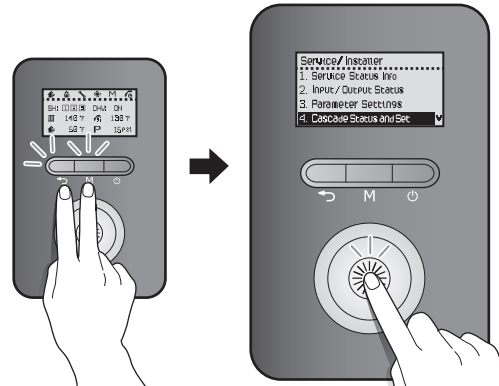

2. Rotate the Command dial (⊙) to switch between the parameters or to increase/decrease setting values. Press the Command dial (⊙) to select "1. Cascade System Setting", and then select "START".

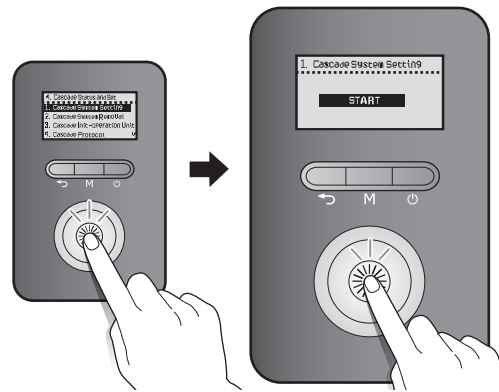

- On the sub NPE water heater panel, press and hold the **Diagnostic** and **Down(-)** buttons for more than 2 seconds. "SL.01" will appear on the display to confirm that this water heater is set as a sub.

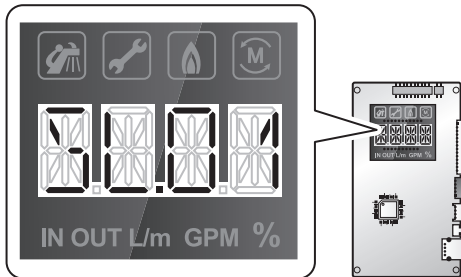

- Repeat step 2 to configure the rest of the sub NPE water heaters in the system.
- On the main NFC boiler panel, press the Command dial (⊙) button when the following screen appears. All the display screens on the configured water heaters will return to the temperature display.



Note

- To add additional sub water heater at a later time, repeat step 2.
- To cancel the cascade communication settings, on the main NFC boiler panel, press the Back button (←) and the Menu button (M) simultaneously for 3 seconds, and then select "4. Cascade Status and Set". Then, select "2. Cascade System Removal" and select "YES". The water heaters will revert to independent operation. To reassign the main NFC boiler, repeat steps 1-4.

9. Installing a Common Vent System

9.1 About the Common Vent System

The Navien Common Vent System* provides an easy way to install the vent system for a NFC boiler unit and up to 7 NPE water heater units. By sharing the main intake and exhaust vent pipes, effective system venting is available with less venting materials and minimal number of penetrations on the walls or roofing.

* Independently tested and approved by CSA

Read all safety messages and carefully follow the guidelines in this manual when installing a common vent system for the NFC boiler units.



WARNING

Improper venting of the boiler units can result in excessive levels of carbon monoxide, which can lead to severe personal injury or death. **The boiler units must be vented in accordance with the “Venting of Equipment” section of the latest edition of the ANSI Z223.1/NFPA 54 Natural Fuel Gas Code in the USA, as well as all applicable local building codes and regulations.** Follow all instructions and guidelines when venting the boiler units. Venting should be performed only by a licensed professional.

9.1.1 Guidelines for a Common Vent System



CAUTION

- To ensure the correct operation of the common vent system,
 - a cascade communication cable **MUST** be installed between all units in the common vent system by the installer.
 - backflow vent dampers must be installed in the exhaust duct of each boiler unit.
 - use **direct vent** (with separate intake and exhaust vent) or **indirect vent** (combustion air drawn from room) systems.
- Common vent installations for use with natural gas and propane are only approved for up to 4,500 ft.
- This manual covers the installation of a common vent system for **NFC boilers only**.

To ensure the safe and correct installation of the common vent system, carefully follow the instructions and guidelines.

- Check to see if all contents are included in the package (refer to the “Included Items” on page 74).
- A NFC boiler unit and up to 7 NPE water heater units may be connected to one common vent system. In a cascade system that has more than 7 NPE water heaters, use 2 common vent systems, or consult Navien.
- Use only approved PVC cements when connecting pipes, joints, or elbows.
- Position the boiler units as close as possible to the vent termination.
- Install a new vent system with this appliance. If an existing vent system is reused, thoroughly inspect it for punctures, cracks, or blockages prior to connecting it to the boiler unit.
- Horizontal vent pipe runs must be supported every 4 feet (1.2 m) (minimum). All vertical vent pipe runs must be supported every 6 feet (1.8 m) (minimum). Support the vent pipe with hangers at regular intervals or as required by local codes.
- Install a backflow damper for each boiler unit. Use only the damper specified in this manual.
- To avoid moisture and frost build-up and to maintain clearances to openings on adjacent homes, 45° elbows, 90° elbows, or tees may be attached to the end of the termination vent pipe to direct the exhaust plumes away from buildings, as long as the total allowable vent lengths, maximum number of elbows, and distances to air intake restrictions are observed.
- If the boiler units will be installed in areas where snow is known to accumulate, protect the vent termination from blockage. Provide a minimum of 1 foot (30 cm) clearance from the bottom of the exhaust of the expected snow accumulation level. Snow removal may be necessary to maintain clearance.
- Ensure that the vent termination is at least 12 in (305 mm) above ground, 12 in (305 mm) above the highest anticipated snow level, or as required by local codes, whichever is greater.
- Support the vent pipe with hangers at regular intervals or as required by local codes.
- The vent for this appliance shall not terminate over public walkways; or near soffit vents or crawl space vents or where condensate or vapor could create a nuisance or hazard or cause property damage; or where condensate or vapor could cause damage or could be detrimental to the operation of regulators, relief valves, or other equipment.

Adequate Installation Clearances

! CAUTION

Do not install the boiler on carpeting.

Install the boiler in an area that allows for service and maintenance access to utility connections, piping, filters, and traps. Based on the installation location, ensure that the following clearances are maintained:

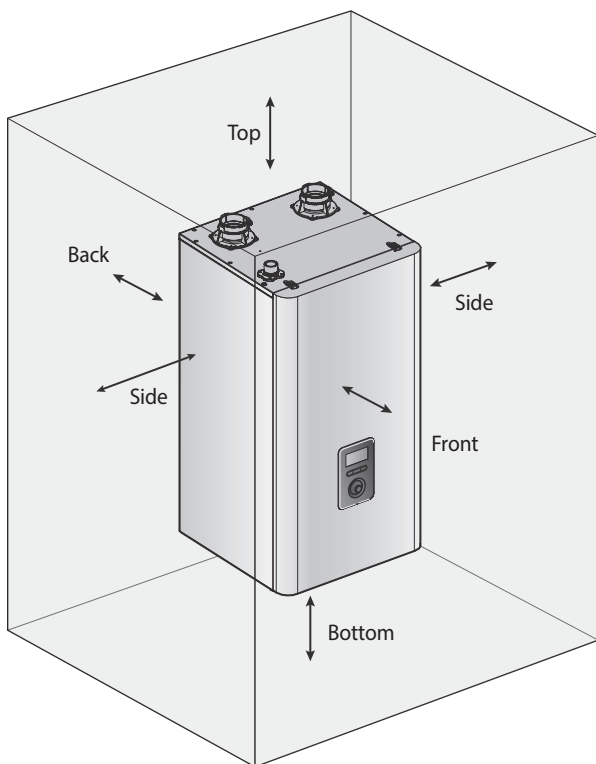

| Clearance from: | Indoor Installation |
|-----------------|------------------------|
| Top | 9 in (229 mm) minimum |
| Back | 0.5 in (13 mm) minimum |
| Front | 4 in (100 mm) minimum |
| Sides | 3 in (76 mm) minimum |
| Bottom | 12 in (300 mm) minimum |

! CAUTION

It is necessary to leave clearance for service access.

Clean, Debris and Chemical-free Combustion Air

- Do not install the boiler in areas where dust and debris may accumulate or where hair sprays, spray detergents, chlorine, or similar chemicals are used.
- Do not install the boiler in areas where gasoline or other flammables are used or stored.
- Ensure that combustible materials are stored away from the boiler and that hanging laundry or similar items do not obstruct access to the boiler or its venting.

General and Local Standards Information

When installing and operating the common vent system, the following standards and regulations must be complied with and adhered to:

- Local codes or, in the absence of local codes, the National Fuel Gas Code, ANSI Z223.1/NFPA 54.
- Appliance manufacturer's Installation Instructions.
- Regulations on the supervision of construction.
- Statutory provisions.
- Installation and service work must be carried out by licensed professionals only.

Risk Guidelines

- Ensure that all common vent system components are manufactured and installed in accordance with valid standards, regulations, and safety engineering rules.
- To avoid risk, the common vent system must be installed and used only for the original purpose described in this manual.
- Defects or damages found in a common vent system must be addressed and repaired immediately.
- For roof or chimney modifications, refer to the relevant industrial safety regulations.
- Works on roofs and facades are dangerous. Comply with all relevant regulations.

Cutting and Assembling Common Vent System

Components

Standard tools are suitable for the cutting and assembly of common vent system components. Follow the guidelines listed below when working with the components.

- When cutting vent components, ensure that the cuts are straight. Chamfer and deburr all edges before installing the components.
- All vent joints must be fully tightened.
- Before operating the system, ensure that the installed vent system is clean and free of debris.
- Ensure that the vent system is rigidly supported according to the manual's instructions.

Selecting Vent Pipe Materials

Consult the following chart or the most recent edition of ANSI Z223.1/NFPA 54, as well as all applicable local codes and regulations when selecting vent pipe materials. This appliance should be vented with materials approved for Category IV gas appliances. Do not use cellular core PVC (ASTM F891), cellular core CPVC, or Radel® (polyphenolsulfone) for the exhaust vent. See below for recommended vent materials.

| Locale | Recommended Vent Materials |
|---------------|---|
| USA | <ul style="list-style-type: none">• PVC Schedule 40 (Solid Core)• CPVC Schedule 40 or 80 (Solid Core)• Approved Polypropylene (Centrotherm Innoflue) |
| Canada* | <ul style="list-style-type: none">• Type BH Special Gas Vent Class IIA (PVC)• Type BH Special Gas Vent Class IIB (CPVC)• Type BH Special Gas Vent Class IIC (Polypropylene/Stainless Steel) |

* For installation in Canada, field-supplied plastic vent piping must comply with CAN/CGA B149.1 (latest edition) and be certified to the Standard. For Type BH Gas Venting Systems, ULC-S636. Components of this listed system must not be interchanged with other vent systems or unlisted pipes or fittings. All plastic components and specified primers and glues of the certified vent system must be from a single system manufacturer and must not be intermixed with another system manufacturer's parts. The supplied vent connector and vent termination are certified as part of the boiler.

Vent Pipe Pitch and Supports

For horizontal runs, slope the horizontal section upward toward the vent termination at a rate of $\frac{1}{4}$ " per foot (2% slope).

Connecting Pipes with Cement

CAUTION

The vapors from primers and solvent cements can cause nausea and can be dangerous to your health. Ensure that the work area is well ventilated, or wear an approved organic vapour respirator when working with primers and solvent cements.

To connect the vent pipes using cement:

1. Spread an even layer of solvent cement on the inside of the pipe fitting and the outside of the pipe.

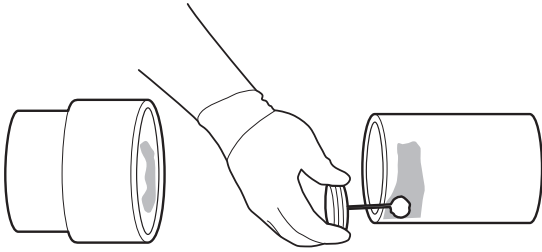

2. Align the pipe with the pipe fitting and twist the pipe a quarter turn as you insert it into the fitting. Twisting the pipe spreads the solvent cement evenly to ensure a solid joint.

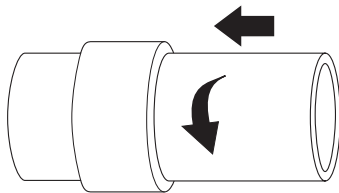

3. Hold the pipe and pipe fitting together for about 15 seconds until the cement sets.

Note

- Use approved solvent type cement for the proper vent materials.
- Use solvent type cement only.
- Check the date of manufacture before using the cement. Ensure that cement was not manufactured more than 2 years prior to using it.
- Ensure that the inside of the pipe fitting and the outside of the pipe, where cement will be applied, is clean.
- Apply an even layer of cement over all mating surfaces.
- Use solvent cement in room temperatures higher than 32°F (0°C).
- Use primer when temperatures are lower than 32°F (0°C).
- Installing vent pipe with cement in cold ambient temperatures can result in longer cure times.

DANGER

Be careful not to apply force or impact to pipes after making connections. An impact may break the bond and harmful gas might leak inside the room.

9.1.2 Determining the Length of a Common Vent System

Follow the instructions listed below to determine the length of a common vent.

1. Add the BTU/H input ratings for each unit in the cascading system to determine the total BTU/H rating.
2. Determine the total length (L) of the common vent, which consists of the horizontal width (W) and the vertical height (H):
Total length (L) = W + H.

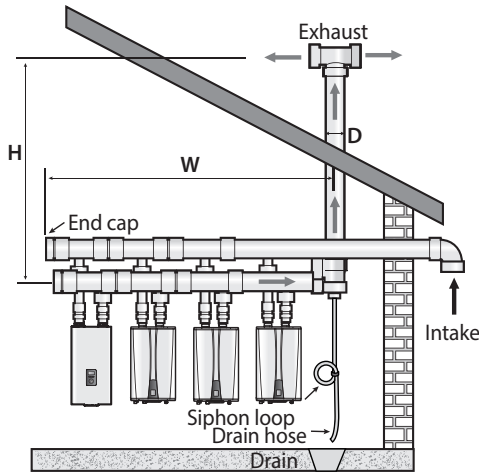

Common Vent Length Table [Total Length (L) = W + H]

Vent Lengths for an NFC Boiler with up to 7 NPE Water Heaters

The following table provides information on the required load amount and the total length for one NFC boiler with up to 7 NPE water heaters installed.

| Required Load (Total BTU/H) | Model | | Total Length (ft) | | | |
|-----------------------------|-------------|---------|-------------------|------|------|------|
| | NFC-175/200 | NPE-240 | D=3" | D=4" | D=6" | D=8" |
| 399,800 | 1 | 1 | 60 | 106 | 200 | |
| 599,700 | | 2 | 40 | 71 | 160 | |
| 799,600 | | 3 | 30 | 53 | 120 | |
| 999,500 | | 4 | | | 96 | 150 |
| 1,199,400 | | 5 | | | 80 | 142 |
| 1,393,300 | | 6 | | | 68 | 121 |
| 1,599,200 | | 7 | | | 60 | 106 |

Note Every 90° elbow used is equivalent to 8 linear feet (2.4 m) of vent length.

Example of a Typical Installation (Direct Vent Only)

The following illustration depicts an example of a common vent system installed for a cascade system of 1 combi-boiler (NFC Model) and 7 Navien water heaters (NPE Model).

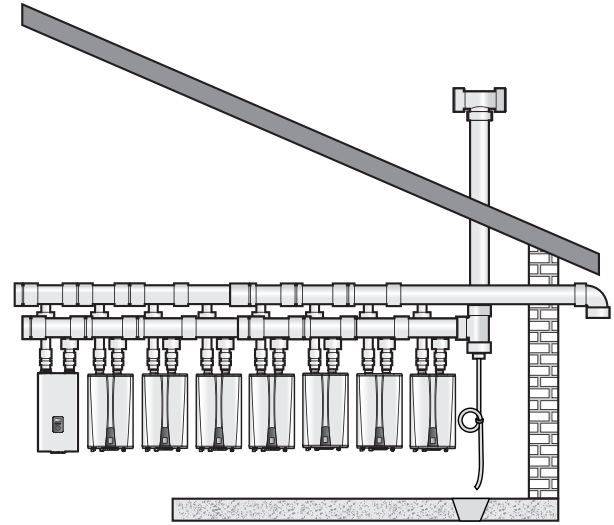

Note

- The illustration is intended for reference purposes only.
- The maximum allowable vent length of the pipe branch connecting the boiler to the common vent trunk is 20 feet.



9.2 Navien Backflow Damper (Back-draft Damper)

The Navien backflow damper prevents backflow (back-draft) at the exhaust vent while the boiler unit operates.

By closing the exhaust vent as soon as the combustion cycle ends, the Navien backflow damper retains heat in the system for longer periods. This improves the system's thermal efficiency.

Note When using a common vent in a cascade system, backflow appliances are required to prevent exhaust from entering the building.

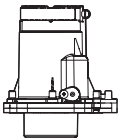
Included Items

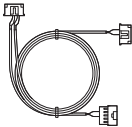
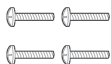
| | |
|--------------------------------|---|
| Backflow Damper |  |
| Installation Manual |  |
| Ready-Link communication cable |  |
| Screw (4 ea) |  |

Specifications

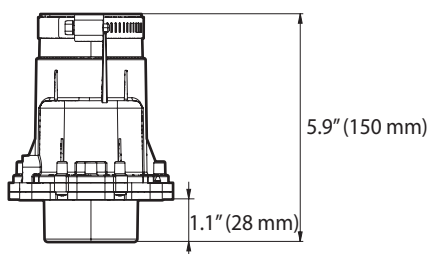

| | |
|-----------|--------------------|
| Part Name | Backflow Damper |
| Part No. | 30014367A |
| Material | PP (Polypropylene) |

Maintenance Port

Navien Backflow Damper has a maintenance port to allow you to easily inspect the operating condition of the damper plate.

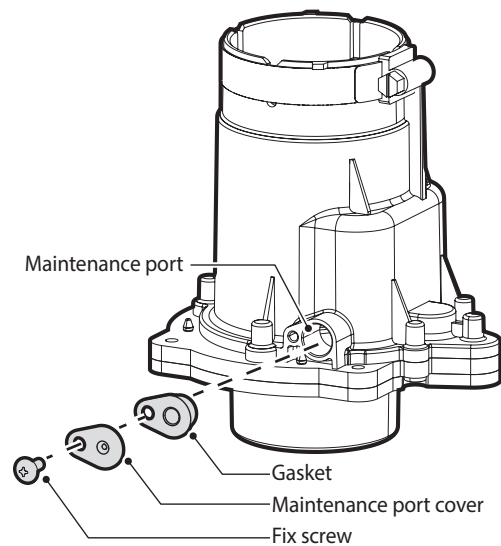
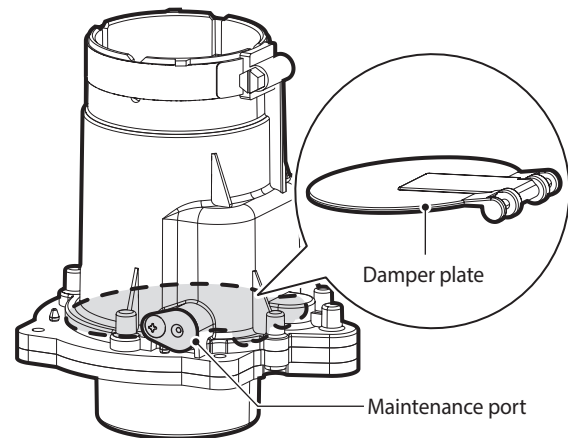

Refer to "9.9 Maintenance" for detailed inspection procedures. Navien Backflow Damper (Back-draft Damper)

9.3 Starting the Common Vent System

9.3.1 Backflow Damper Assembly

Follow the instructions below to assemble the backflow damper on the NFC boiler unit:

1. Remove the screws from the exhaust vent adapter.

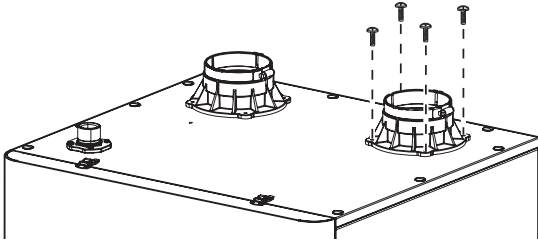

2. Detach the exhaust vent adapter.

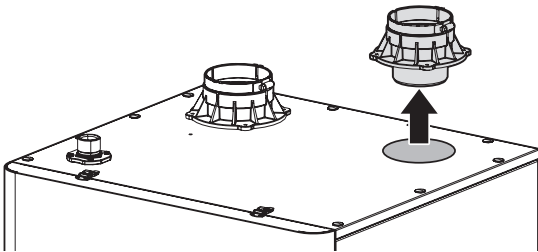

3. Connect the backflow damper to the exhaust duct of the boiler unit.

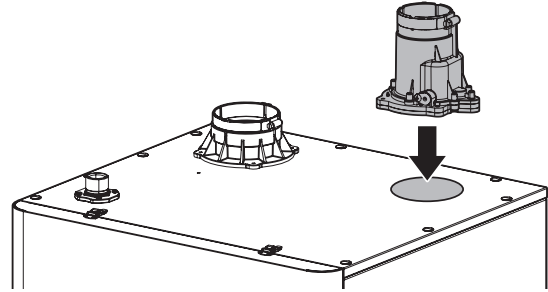

4. Tighten the four mounting screws to secure the backflow damper in place. The screws (x 4) are supplied with the backflow damper.

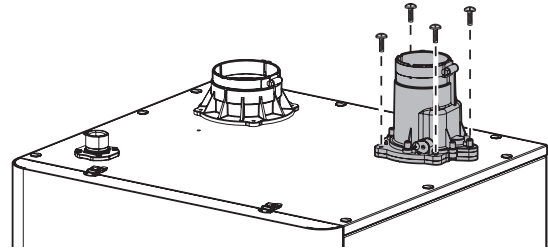

9.3.2 Connecting the Pipe to the Damper

1. Measure 1-1/2" from the end of the vent pipe, then draw a mark at that distance.

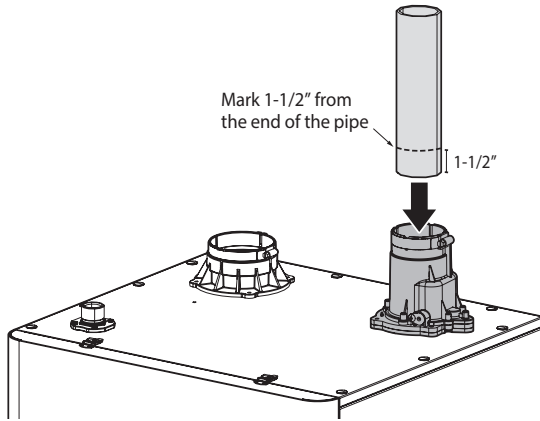

2. Insert the vent pipe into the vent collar to start the vent run. Make sure to completely slide the vent into the collar until the end makes contact with the bottom of the socket.

Note Verify that 1-1/2" of the pipe has been completely inserted into the collar and that the mark is no longer visible.

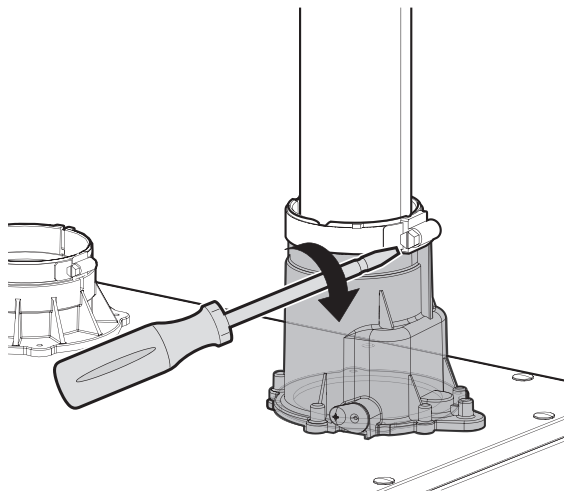

3. Tighten the clamp with a screwdriver to properly seal the joint.

CAUTION

Do not start the vent run with a 90° street elbow at the vent collar. Using a street elbow directly at the collar will not allow for a tight seal between the appliance and vent pipe. A length of straight pipe must be used when starting the vent run.

Note The length of vent pipe from the unit to the common vent main trunk pipe must not exceed 20' of equivalent length.

9.3.3 Assembling the T Joint

1. Use the proper reducers to connect the 2" branch pipe from the unit to the common vent tee joint. Apply the proper solvent cement to the mating surfaces.

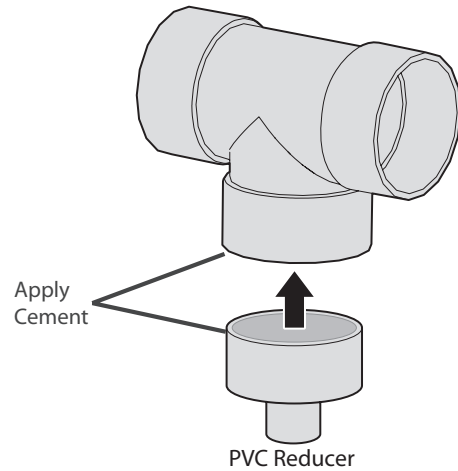

Note Multiple reducers can be used to allow proper connection of 2" vent pipe to the common vent system.

2. Assemble the tee joint assembly to the vent pipe. Apply solvent cement to the mating surfaces.

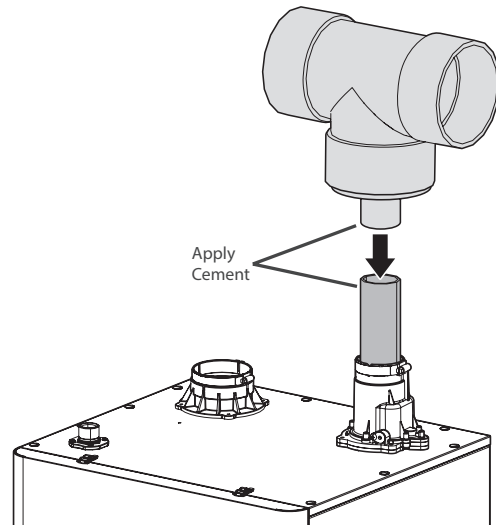

9.4 Connecting and Terminating the Vent Pipe

Refer to the following example to install the common vent system. The installation area should be measured to ensure that sufficient space is available to install the boiler units and the common vent system. Ensure that the common vent system is installed near the boiler units while satisfying all clearance requirements that are specified in this manual as well as the Installation Manuals supplied with the boiler units.

9.4.1 Connecting the Main Pipe Runs to T Joint

After connecting the tee joint to the branch pipe, connect the main trunk pipe to each side of the tee. Each trunk pipe is connected to the other tee joint. Refer to "Connecting Pipes with Cement" on page 72 for more information.

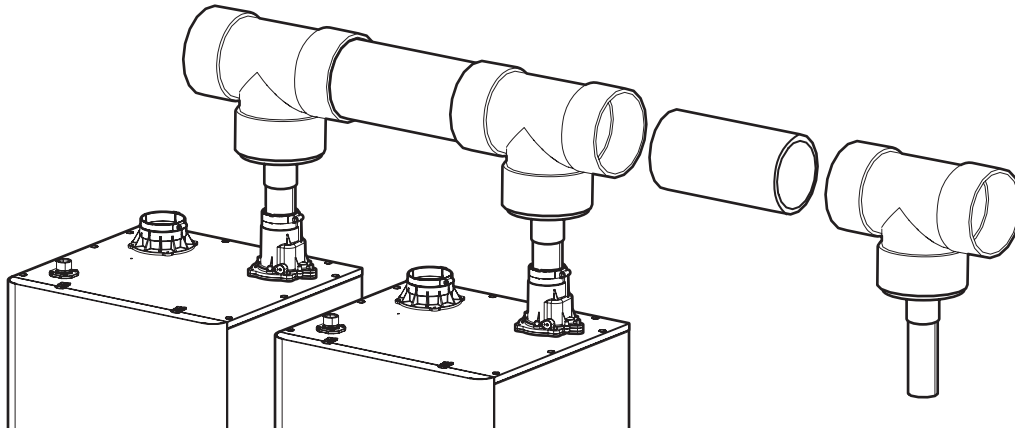

9.4.2 Installing the System Termination

End caps, pipe elbows or tee joints can be used at the open ends of the intake and exhaust vent pipes. Refer to the following installation examples that depict how the parts are fitted at the end of the common vent system piping.

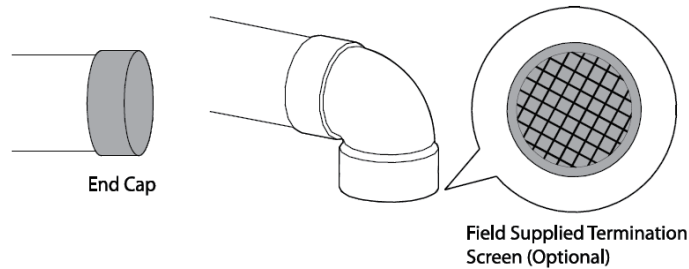

Note

The illustration is intended for reference purposes only.

9.5 Setting Up the Common Vent System

Refer to the following figures when setting the common vent type.

To view and configure the cascade settings, press the Back button (⏪) and the Menu button (M) simultaneously for 3 seconds, and then select "4. Cascade Status and Set".

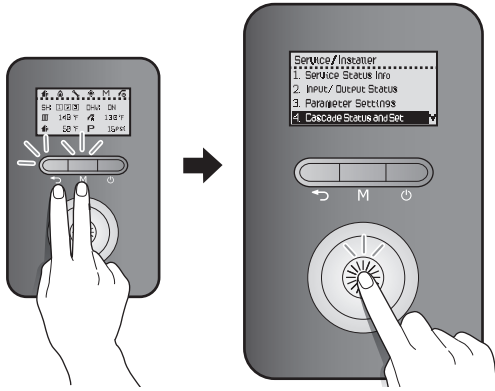

Rotate the Command dial (⊙) to switch between the parameters or to increase/decrease setting values. Press the Command dial (⊙) to select "7. Vent Type Setting".

Note For more information on the vent type settings, refer to "11.4.4 Configuring a Cascade System" on page 97.

9.6 Common Vent Termination Clearances

9.6.1 Direct Vent Application – Vertical Installation

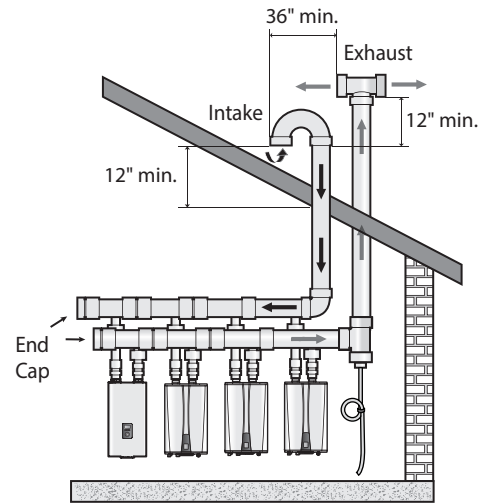

9.6.2 Venting Intake and Exhaust to Different Locations

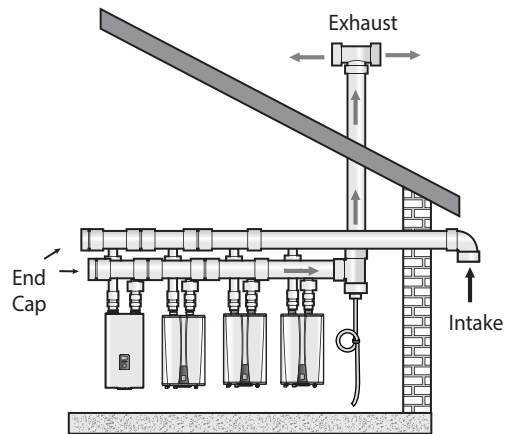

9.6.3 Direct Vent Application – Horizontal Installation

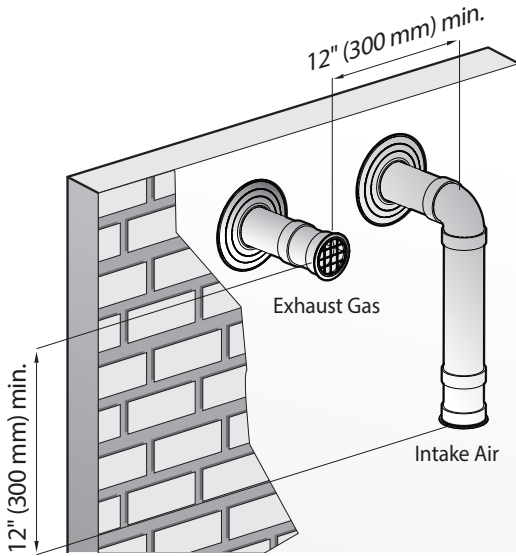

Note

- The illustration is intended for reference purposes only.
- Direct the exhaust away from any building openings.
- During cold weather situations, the temperature of the exhaust will be much warmer than the ambient air. Therefore, you will see water vapor being produced at the termination.

In cases where a 12" horizontal clearance is not possible, provide a vertical clearance of at least 36" with the exhaust above the intake but do not exceed 20'.

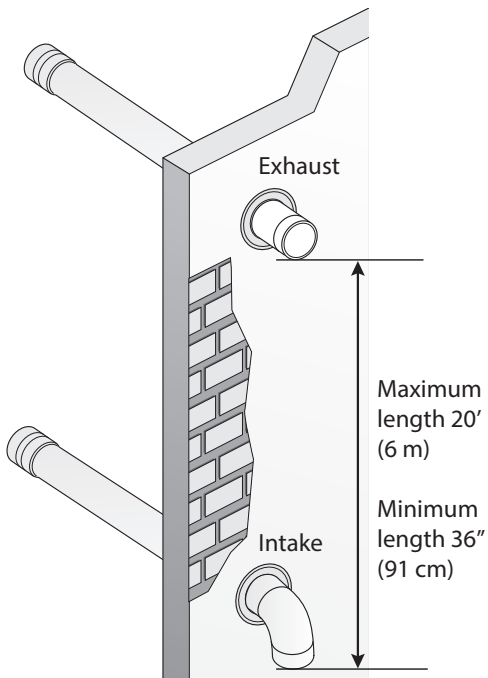

9.7 Installing a Condensate Drain

Refer to the following examples to install a condensate drain hose (field supplied) to the common vent system. The condensate drain hose prevents condensate or rain from entering the exhaust system and gathering above the backflow damper.

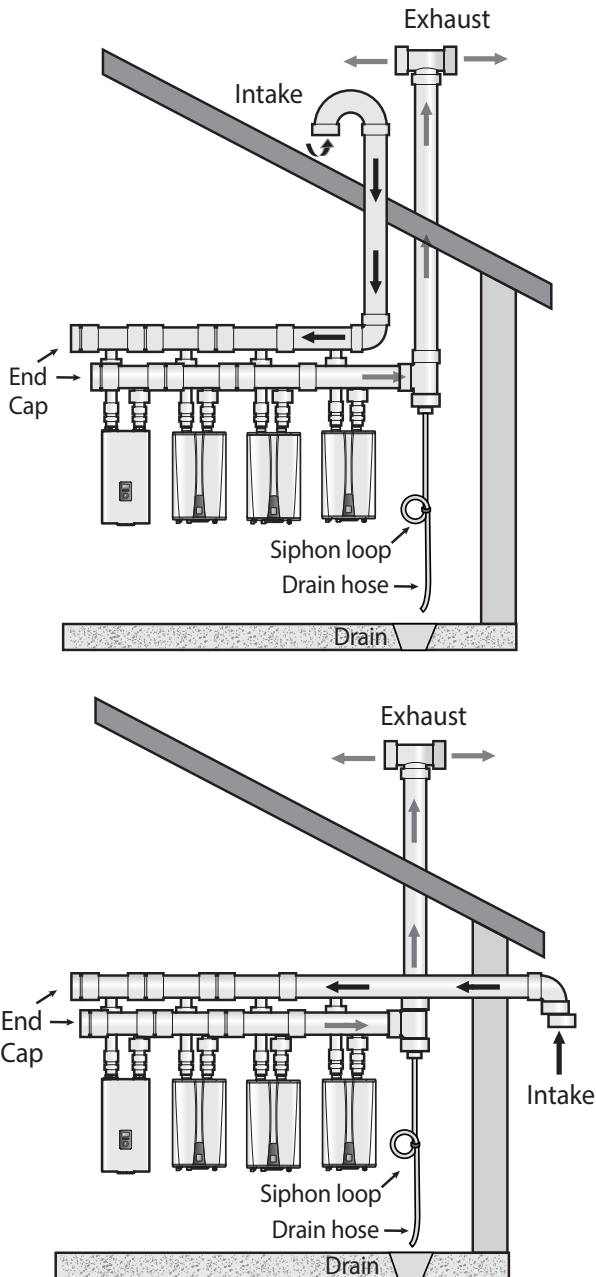

To install a condensate drain to the cascade system:

1. Form a loop with a drain hose and fix it with a tie.

Note

- While shaping the hose, do not bend the hose excessively. The hose will be deformed and the flow will be restricted if the hose is bent in sharp angles.
- Do not fix the hose too tight when tying the hose to form the loop. The hose will be deformed and the flow will be restricted if the tie is too tight.

2. Prime the loop using tap water.

3. Install the hose to the cascade system and direct the end of the hose to a drain.

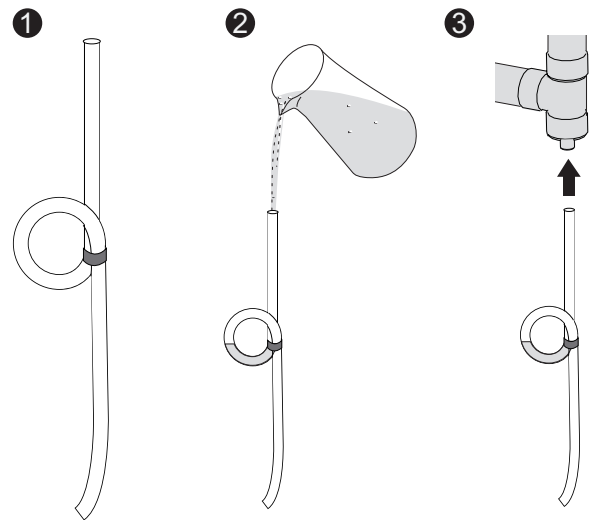

WARNING

After installing the condensate drain hose, check the loop again to ensure that the prime water is not spilled. The loop (siphon) must be primed with water before running the system to prevent toxic exhaust gas from leaking into the installation site.

9.8 Exhaust Vent Termination Clearances (For Direct Vent)

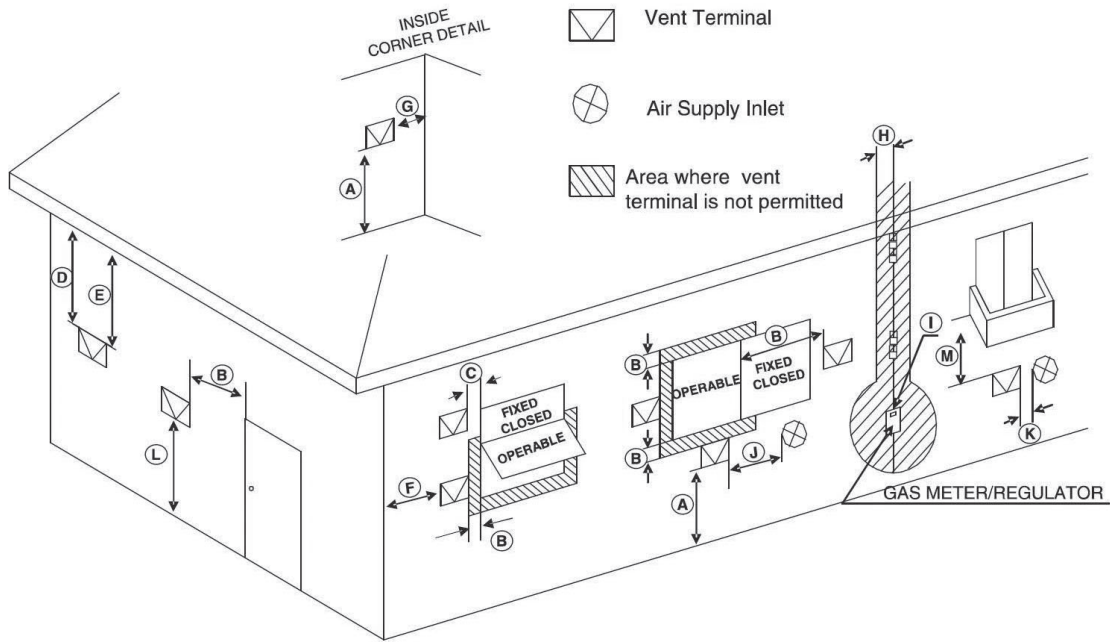

| Ref | Description | Canadian Direct Vent Installations ¹ | U.S. Direct Vent Installations ² |
|-----|--|---|---|
| A | Clearance above grade, veranda, porch, deck, or balcony | 12 in (30 cm) | 12 in (30 cm) |
| B | Clearance to window or door that may be opened | 12 in (30 cm) | 12 in (30 cm) |
| C | Clearance to permanently closed window | * | * |
| D | Vertical clearance to ventilated soffit located above the terminal within a horizontal distance of 2 feet (61 cm) from the center line of the terminal | * | * |
| E | Clearance to unventilated soffit | * | * |
| F | Clearance to outside corner | * | * |
| G | Clearance to inside corner | * | * |
| H | Clearance to each side of center line extended above meter/regulator assembly | 3 ft (91 cm) within a height 15 ft above the meter/regulator assembly | * |
| I | Clearance to service regulator vent outlet | 3 ft (91 cm) | * |
| J | Clearance to nonmechanical air supply inlet to building or the combustion air inlet to any other appliance | 36 in (91 cm) | 12 in (30 cm) |
| K | Clearance to a mechanical air supply inlet | 6 ft (1.83 m) | 3 ft (91 cm) above if within 10 ft (3 m) horizontally |
| L | Clearance above paved sidewalk or paved driveway located on public property | 7 ft (2.13 m)† | * |
| M | Clearance under veranda, porch deck, or balcony | 12 in (30 cm)‡ | * |

¹ In accordance with the current CSA B149.1 Natural Gas and Propane Installation Code

² In accordance with the current ANSI Z223.1 / NFPA 54 National Fuel Gas Code

† A vent shall not terminate directly above a sidewalk or a paved driveway that is located between two single family dwellings, that serves both dwellings.

‡ Permitted only if the veranda, porch, deck, or balcony is fully open on a minimum of two sides beneath the floor.

* Clearance in accordance with local installation codes and the requirements of the gas supplier.

9.9 Maintenance

Periodically check the damper condition inside the backflow damper through the maintenance port to ensure optimal performance of the system. Follow the instructions to check the damper condition and replace the backflow damper if necessary.

1. Remove the screw that fixes the maintenance port cover to the backflow damper, and then remove the gasket and the maintenance port cover.

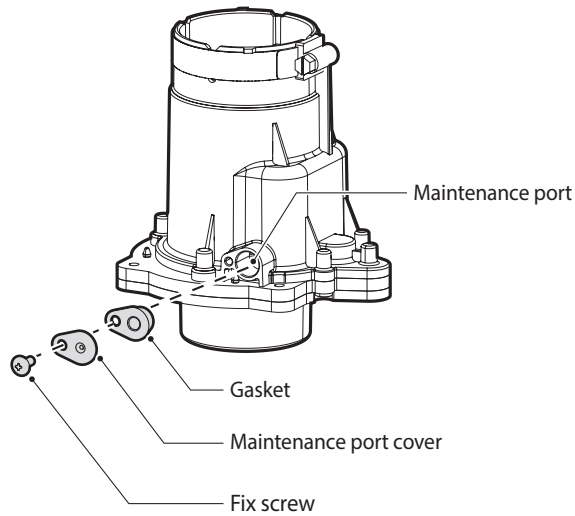

2. Through the maintenance port, check the operating condition of the damper plate inside the backflow damper.

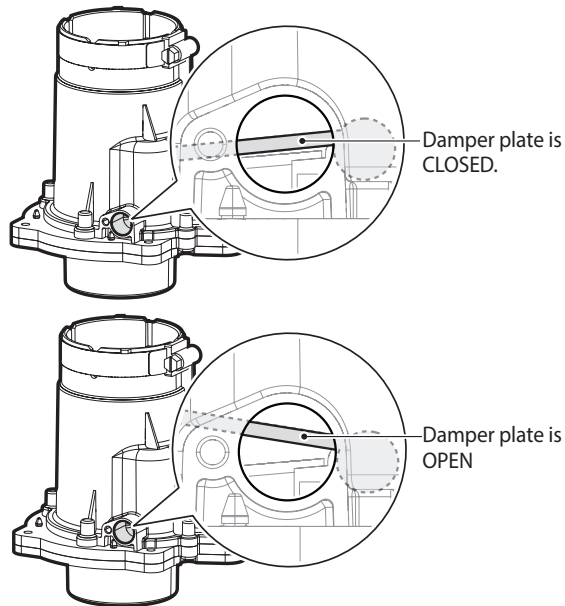

3. Reinstall the gasket and maintenance port cover, and then fix them with a set screw.

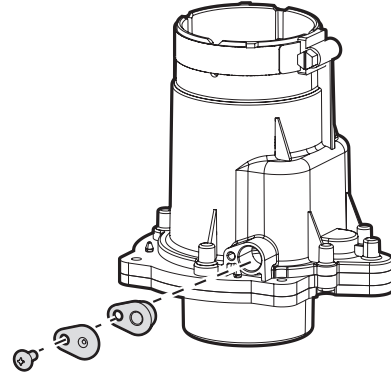

4. Visually inspect the maintenance port to ensure that the gasket is properly installed between the maintenance port and the maintenance port cover.

WARNING

Ensure that the gasket is properly installed under the maintenance port cover, after checking the operating condition of the damper plate through the maintenance port. Harmful exhaust gas may leak if the gasket is not installed, or if it is not installed properly.

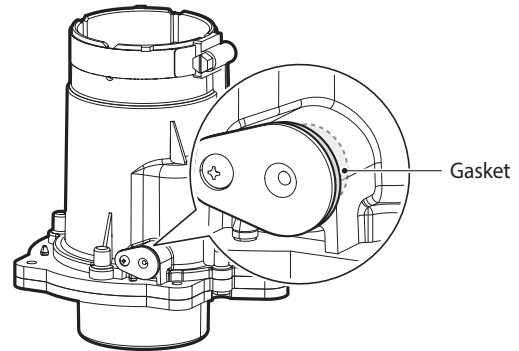

10. Installation Checklist

After installing the boiler, review the following checklist. You should be able to answer "Yes" to all of the items in the checklist. If not, review the appropriate sections to complete the installation. To troubleshoot any operational problems refer to "Troubleshooting" in the Owner's Manual.

If you have additional questions or need assistance with installation, contact Technical Support at 1-800-519-8794 or 1-949-420-0420, or refer to the technical support section of Navien's website (www.navien.com).

| Installing the boiler | Yes | No |
|--|-----|----|
| Have you maintained the required clearances from building openings and intake air vents? | | |
| Have you minimized the distance between the boiler and major fixtures? | | |
| Have you maintained the proper service and maintenance clearances? | | |
| Is the make-up air supply sufficient for proper operation? | | |
| Is the make-up air supply free from dust, dirt, corrosive elements, and flammable vapors? | | |
| Is the boiler and vent piping clear of combustibile materials, including clothing, cleaning materials, and rags? | | |

| Connecting the Gas Supply | Yes | No |
|--|-----|----|
| Does the gas supply match the type specified on the boiler's rating plate? | | |
| Is the gas line at least 1/2 or 3/4 in ID (Inner Diameter)? | | |
| Is the gas supply line sufficient in length and diameter to deliver the required BTUs? | | |
| Have you measured the pressure of the gas supply line? | | |
| Is the gas supply pressure within the recommended ranges specified in this manual? | | |
| Is the gas supply line equipped with a manual shut-off valve? | | |
| Have you tested the gas line pressure and all fittings for leaks? | | |
| Has the gas company inspected the installation, if required? | | |

| Connecting the Domestic Water Supply | Yes | No |
|--|-----|----|
| Is the water supply pressure sufficient (greater than 40 psi)? | | |
| Have you installed shut off valves on the inlet and outlet to facilitate cleaning of the inlet water filter? | | |
| Have you bled the air out at each fixture? | | |
| Have you checked each fixture to ensure hot water is being supplied? | | |
| Have you cleaned the inlet water filter? | | |
| If you installed a recirculation line, have you insulated the hot water pipes and the return line? | | |

| Connecting the Space Heating Piping | Yes | No |
|--|-----|----|
| Has the system been filled (less than 80 psi) and purged of air? | | |
| Does the piping incorporate means for air removal (scoop, separator, etc.)? | | |
| Is there an expansion tank installed and set to the proper system pressure? | | |
| If antifreeze has been used, is it the proper type and is the concentration appropriate? | | |
| If an external low water cut off (LWCO) is installed, is it wired to the boiler? | | |

| Connecting a Pressure Relief Valve | Yes | No |
|---|-----|----|
| Have you installed an approved pressure relief valve on the boiler? | | |
| Does the rating of the pressure relief valve match or exceed the maximum BTU rating of the boiler? | | |
| Is the pressure relief valve $\frac{3}{4}$ in on the space heating outlet? | | |
| Have you installed the pressure relief valve on the space heating supply pipe near the boiler? | | |
| Have you installed a discharge drain tube from the pressure relief valve to within 6-12 in (150-300 mm) of the floor? | | |

| Connecting the Condensate Drain | Yes | No |
|---|-----|----|
| Have you installed a condensate drain line from the boiler to a drain or laundry tub? | | |

| Venting the boiler | Yes | No |
|--|-----|----|
| Have you vented the boiler with 2 in or 3 in PVC, CPVC, polypropylene, stainless steel, Type BH Special Gas Vent (ULC-S636) for Category IV boilers (Canada), or in accordance with all local codes and the guidelines in this manual? | | |
| Have you ensured that ABS or PVC cellular core pipe has not been used as venting for the boiler? | | |
| Is the vent sloped upward toward the vent termination at a rate of $\frac{1}{4}$ in per foot (2% grade)? | | |
| Are all vent runs properly supported? | | |
| Is the vent termination properly supported? | | |
| Are the air intake and exhaust connections on the flue and vent lines correctly sealed? | | |
| Have you installed end caps on the exhaust and intake pipes? | | |
| Have you checked the venting for leaks? | | |
| Is the vent termination at least 12 in (300 mm) above the exterior grade? | | |
| Have you ensured that sufficient make-up air is available? | | |
| Is the total vent length within the maximum vent length restriction? | | |

| Connecting the Power Supply | Yes | No |
|--|------------|-----------|
| Is the supplied voltage 110-120V AC? | | |
| Is the boiler plugged into a properly grounded outlet? | | |
| If you have made a direct power supply connection, have you installed a power switch to facilitate end-user maintenance? | | |
| Have you checked the polarity of the electrical connection? | | |

| PCB DIP switch setting (DIP SW 2, set of 8) | Yes | No |
|---|------------|-----------|
| Gas type: Is switch #1 set correctly for LP (ON) or NG (OFF)? | | |
| If continuous boiler operation is required, is switch #7 in the up (ON) position? | | |
| If high temperature venting has been installed (CPVC or polypropylene), is switch #8 in the up (ON) position? | | |

| Operating the boiler | Yes | No |
|---|------------|-----------|
| Have you shown the owner how to clean the inlet water filter? | | |
| Have you given the Installation & Operation Manual and User's Information Manual to the owner for future reference? | | |
| Have you shown the owner how to shut off the gas in case of an emergency? | | |

11. Operating the Boiler

11.1 Turning the Boiler On or Off

To turn the boiler on or off, press the Power button for 0.3 seconds.

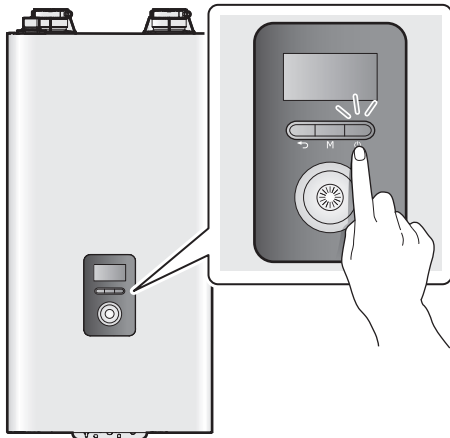

When the power is on, the boiler automatically enters normal operation mode, and the boiler's operating conditions are displayed on the screen.

Note The boiler status icons remain displayed when the boiler is turned off.

11.2 Adjusting the Temperature

11.2.1 Adjusting the Space Heating Temperature

To adjust the heating temperature:

1. In normal operation mode, rotate the Command dial (🌀). The space heating temperature (📊) is highlighted on the screen.

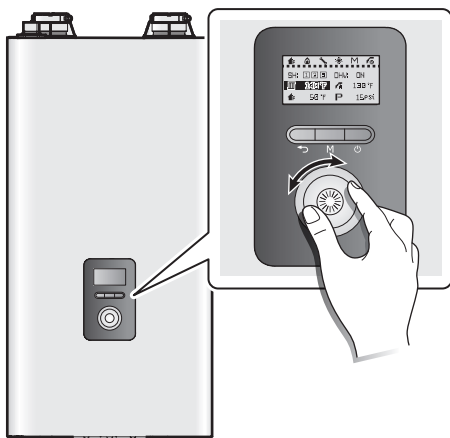

2. Press the Command dial (🌀) to select the space heating temperature. The highlighted section will flash.

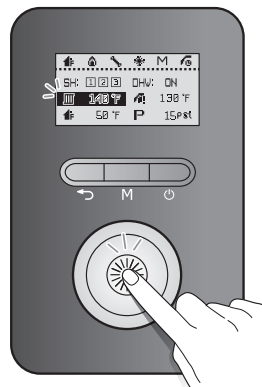

3. Rotate the Command dial (🌀) to the right or left to increase or decrease the temperature.
4. Press the Command dial (🌀) to confirm the new temperature.
5. Press the Back button (↶) to return to normal operation mode, or rotate the Command dial (🌀) to adjust other operation conditions.

You can adjust the temperature while the highlighted section is flashing. Once the flashing stops, the current temperature setting is stored.

- Note**
- The space heating temperature cannot be adjusted when the Outdoor Reset Control is used.
 - The space heating temperature cannot be adjusted if the boiler is operating as a sub unit in a cascade system. The main unit's set temperature will be displayed on the screen.
 - In case of outdoor reset sensor malfunction, the boiler will operate at this set temperature.
 - Take note of the original heating temperature in case you want to restore it to the default.
 - The default space heating supply water temperature range is 104°F (40°C, Absolute MIN) to 180°F (82°C, Absolute MAX).
 - The default space heating return water temperature range is 86°F (30°C, Absolute MIN) to 149°F (65°C, Absolute MAX).
 - You can adjust the temperature ranges in the parameter settings menu.
 - The boiler will retain your settings during a power outage.

11.2.2 Adjusting the DHW Temperature

To adjust the water temperature:

1. In normal operation mode, rotate the Command dial (☀️). The space heating temperature (🏠) is highlighted on the screen.

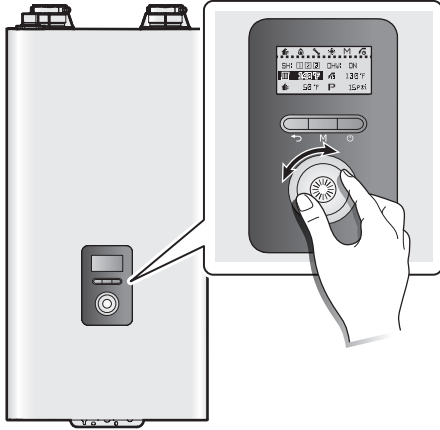

2. Rotate the Command dial (☀️) to the right to select the DHW temperature.

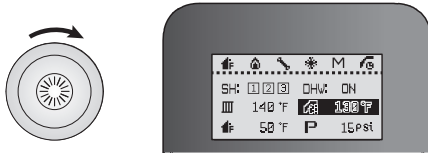

3. Press the Command dial (☀️) to select the DHW temperature (🚿). The highlighted section will flash.

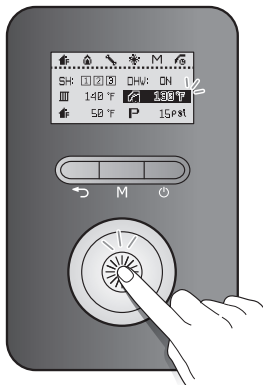

4. Rotate the Command dial (☀️) to the right or left to increase or decrease the temperature.
5. Press the Command dial (☀️) to confirm the new temperature.

6. Press the Back button (↩️) to return to normal operation mode, or rotate the Command dial (☀️) to adjust other operation conditions.

You can adjust the temperature while the display is flashing. Once the display stops flashing, the current temperature setting is stored.

Note

- The default DHW temperature range is 86°F (30°C) to 140°F (60°C).
- You can adjust the temperature ranges in the parameter settings menu.
- The boiler will retain your settings during a power outage.

11.2.3 Resetting the Boiler

If an error message appears during boiler operation, reset the boiler to resolve the problem. Press the Back button (↩️) on the front panel to reset the boiler.

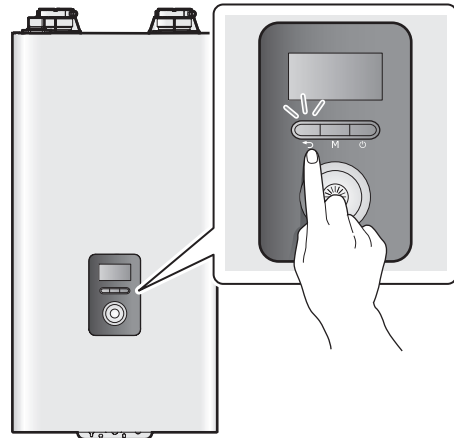

If resetting the boiler does not solve the problem, refer to the Troubleshooting section of this manual or contact Technical Support at 1-800-519-8794.

11.3 Accessing Basic Menu Items

In the Main Menu screen, you can view the boiler's operating conditions, configure the space heating and DHW temperatures, and review error history. Press the Menu button (M) to enter the Main Menu screen.

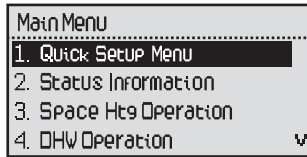

11.3.1 Quick Setup Menu

The Quick Setup Menu is designed to help configure the boiler settings after installation is complete. To enter the Quick Setup Menu, press the Menu button (M), and select "1.Quick Setup Menu". Press the Back button (←) to return to the previous screen.

| Item | Description |
|----------------------------|---|
| 1. Outdoor Reset ON/OFF | Set the Outdoor Reset Control settings. |
| 1-1. Outdoor Reset Curves | Set the Outdoor Reset Curve when the Outdoor Reset is used. |
| 1-2. Outdoor High Temp Set | Set the maximum value for the Outdoor Reset Control when the Outdoor Reset is used. |
| 1-3. Outdoor Low Temp Set | Set the minimum value for the Outdoor Reset Control when the Outdoor Reset is used. |
| 1-4. WWSD Temp | Set the WWSD temperature. |
| 2. Auto-Fill Pressure | Set the Auto-Fill Pressure. |
| 3. Time Setting | Set the system clock (RTC). • Display format: YYYY.MM.DD / HH:MM:SS |
| 4. DHW Recirculation | Set the DHW Recirculation type setting. |

11.3.2 Viewing Basic Information

To view information about the boiler, press the Menu button (M), and then select "2. Status Information".

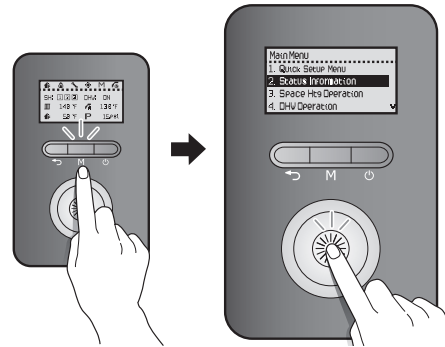

Rotate the Command dial (⊙) to switch between the information items. Press the Command dial (⊙) to select an item and view the information.

Press the Back button (←) to exit information view mode.

| Item | Description |
|-------------------------|--|
| 1. Operation State | Current Operation State |
| 2. Heat Capacity | Heat Capacity (%) |
| 3. SH Set Temp | Space heating set temperature (°F) |
| 4. DHW Set Temp | DHW set temperature (°F) |
| 5. Supply Temp | Heating supply temperature (°F) |
| 6. Return Temp | Boiler return temperature (°F) |
| 7. Sys Supply Temp | System supply temperature (°F) |
| 8. Sys Return Temp | System return temperature (°F) |
| 9. Outlet 1 Temp | Heat exchanger outlet temperature (°F) |
| 10. Outlet 2 Temp | Outlet temperature (°F) |
| 11. Inlet Temp | Inlet temperature (°F) |
| 12. Outdoor Temp | Outdoor temperature (°F) |
| 13. Approx. Boiler Flow | SH flow rate (GPM) |
| 14. DHW Flow | DHW flow rate (GPM) |
| 15. Water Press | Water pressure (psi) |
| 16. Flame Value | Flame detector AD value • Flame On: 8bit AD values equal to or lower than 70 • Flame Off: 8bit AD values equal to or higher than 175 |

| Item | Description |
|-------------------------------|---|
| 17. Fan Target RPM | Set fan speed (RPM) |
| 18. Fan Current RPM | Fan speed (RPM) |
| 19. Fan Target APS | Set APS voltage (V) |
| 20. Fan Current APS | APS voltage (V) |
| 21. Flow control valve status | 100 - Close state |
| 22. Mixing valve status | 0 - Close state |
| 23. Exhaust Temp | Exhaust temperature (°F) |
| 24. Outdoor Reset | Outdoor reset status (Enable / Disable) |
| 25. Outdoor Reset Curve | Outdoor reset curve load type (displayed when the outdoor reset option "20. Outdoor Reset" is enabled) 1: Finned Tube Baseboard 2: FAN Coil 3: Cast Iron Baseboard 4: Low Mass Radiant 5: High Mass Radiant 6: Radiator 7: Custom (set by installer) |
| 26. Boost Interval Time | Boost interval set time (min) |
| 27. High Altitude | Sea Level (0 - 2,000 ft) |
| | Level 1 (2,000 - 5,400 ft) |
| | Level 2 (5,400 - 7,700 ft) |
| | Level 3 (7,700 - 10,100 ft) |
| 28. Well pump | Well pump status OFF - Unused, ON - Used |
| 29. Model | Model type |
| 30. Gas | Fuel type (NG/LPG) |
| 31. Main F/W Ver | Main firmware version |
| 32. Panel F/W Ver | Controller panel firmware version |

11.3.3 Setting the Space Heating Operation

To set the boiler's space heating operation, press the Menu button (M), and then select "3. Space Htg Operation".

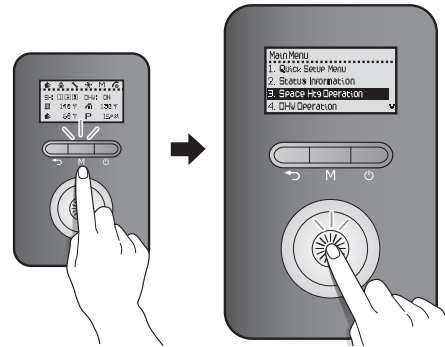

Rotate the Command dial (⊗) to switch between the list items or to increase/decrease setting values. Press the Command dial (⊗) to select an item or to confirm after making changes.

Press the Back button (↶) to return to the previous screen or menu.

| Item | Description |
|------------------------------|--|
| 1. SH Set Temp | Set space heating target temperature (°F). • Setting range: 104–180°F (40–82°C) • Default: 180°F (82°C) This option is available only when "1. Space Htg ON/OFF" is set to "Enabled". |
| 2. Outdoor Reset ON/OFF | Default: Disable |
| 2-1. Outdoor Reset Curves* | Select a heatload type of the Outdoor Reset Control. 1: Finned Tube Baseboard 2: FAN Coil 3: Cast Iron Baseboard 4: Low Mass Radiant 5: High Mass Radiant 6: Radiator 7: Custom (set by installer) This option is available only when "2. Outdoor Reset ON/OFF" is set to "Enabled". |
| 2-2. Outdoor High Temp Set** | Set the maximum temperature for the Outdoor Reset Control. • Setting range: [MIN Set-point + 9°F (5°C)] – 104°F (40°C) • Default: 70°F (21°C) |

| Item | Description |
|-----------------------------|---|
| 2-3. Outdoor Low Temp Set** | Set the maximum temperature for the Outdoor Reset Control. <ul style="list-style-type: none"> Setting range: -4°F (-20°C) – [MAX Set-point – 9°F (5°C)] Default: 14°F (-10°C) |
| 2-4. WWSD Temp | Set the Warm Weather Shut-down temperature. <ul style="list-style-type: none"> Setting range: OFF, 50°F (10°C) – 104°F (40°C) Default: OFF |
| 2-5. WWSD On Diff | Set the differential temperature to deactivate the Warm Weather Shut-down. <ul style="list-style-type: none"> Setting range: 0°F (0°C) – 36°F (20°C) Default: 5°F (3°C) |
| 2-6. Boost Interval Time*** | Set the boost interval time. <ul style="list-style-type: none"> Setting range: 0 – 120 min Default: 0 min |
| 3. Navien zone cont. | Enable or disable heating zones utilizing the Navien Zone Controller. <ul style="list-style-type: none"> Setting range: Enabled/Disabled Default: Disabled |
| 4. SH Control Method | Select a heating control type. <ol style="list-style-type: none"> Supply Temperature Return Temperature Sys Supply Temperature Sys Return Temperature <ul style="list-style-type: none"> Default: Supply Temperature |

* A preset or user defined temperature range is set automatically based on the curve selected. Refer to the settings table for details.

| Heat Load | Supply Set Point Range | Return Set Point Range | Remarks |
|--------------------------|-------------------------|-------------------------|--------------|
| 1. Finned Tube Baseboard | 120–180°F (48.5–82°C) | 101–147°F (38–63.5°C) | Default |
| 2. Fan Coil | 140–180°F (60–82°C) | 116–147°F (46.5–63.5°C) | |
| 3. Cast Iron Baseboard | 100–170°F (37.5–76.5°C) | 86–139°F (30–59°C) | |
| 4. Low Mass Radiant | 80–140°F (26.5–60°C) | 70–116°F (21–46.5°C) | |
| 5. High Mass Radiant | 80–120°F (26.5–48.5°C) | 70–101°F (21–38°C) | |
| 6. Radiators | 120–170°F (48.5–76.5°C) | 101–139°F (38–59°C) | |
| 7. Custom | 104–180°F (40–82°C) | 86–149°F (30–65°C) | User-defined |

Heat loads 1-6 show the preset temperature ranges based on the load type selected, while heat load 7 provides a custom temperature range. When the custom temperature range is in use, the boiler operates based on the user-defined “Absolute Min” and Absolute Max” temperature settings.

** Available only when “2. Outdoor Reset ON/OFF” is set to “Enabled”.

*** The boost interval time may be set to prevent interruption in space heating while using the Outdoor Reset Control mode, due to changes in heat load conditions. With the boost interval time enabled, the boiler increases the space heating supply temperature by 9°F (5°C) and the return temperature by 5°F (3°C) after a set time elapses.

! CAUTION

An outdoor sensor error may occur if the Outdoor Reset Control mode is enabled without the outdoor sensor installed

Note

In the Outdoor Reset Control mode, the boiler’s water temperature is regulated according to the outdoor temperature to maximize boiler efficiency and reduce energy usage. This mode must remain enabled and the outdoor sensor must be installed to comply with federal efficiency regulations. The Outdoor Reset mode cannot be used when using the DHW mode.

11.3.4 Setting the DHW Operation

To set the boiler’s DHW operation, press the Menu button (M), and then select “4. DHW Operation”.

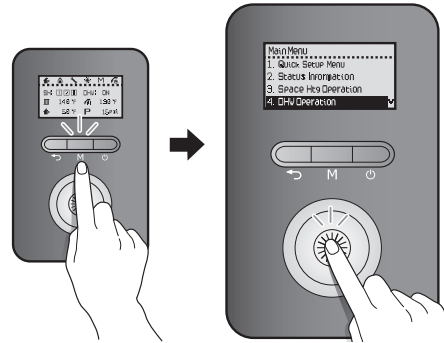

Rotate the Command dial (⊙) to switch between the list items or to increase/decrease setting values. Press the Command dial (⊙) to select an item or to confirm after making changes.

Press the Back button (↩) to return to the previous screen or menu.

| Item | Description |
|----------------------|---|
| 1. DHW Set Temp | <p>Set the hot water temperature(°F).</p> <ul style="list-style-type: none"> • Setting range: 86 - 140°F (30 - 60°C) • Default: 122°F (50°C) |
| 2. DHW Recirculation | <p>When only one NFC boiler is connected: Set the Recirculation type and Schedule settings.</p> <ul style="list-style-type: none"> • Recirculation type <ul style="list-style-type: none"> - No Recirculation - Combi Pre-Heat - External <p>Note External recirculation cannot be used for cascade systems.</p> <p>Recirculation type settings (Combi Pre-heat/External)</p> <ul style="list-style-type: none"> • Set to Combi Pre-heat (Default: Always On) <ul style="list-style-type: none"> - Always On - Intelligent - Weekly <p>Note Intelligent mode cannot be used for cascade systems.</p> <ul style="list-style-type: none"> • Set to External (Default: Always On) <ul style="list-style-type: none"> - Always On - Intelligent - Weekly - Aquastat - Manual |

When installing only one NFC boiler, refer to “3.6.4 System Application - Air Handler System” and Chapters 3.6.6, 3.6.7 on connecting system applications.

Combi Pre-Heat

When using the combi pre-heat feature, you can choose commands in the menu to preheat according to the set DHW temperature.

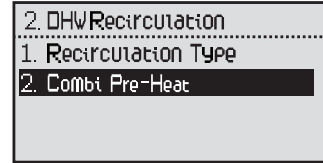

| Item | Description |
|-----------------|---|
| 1. Always On | Set to repeat DHW Recirculation (default). |
| 2. Intelligent* | Set to detect DHW usage for a week and repeat the detected cycle. |
| 3. Weekly* | <p>The user can choose commands for DHW Recirculation on a weekly basis.</p> <ol style="list-style-type: none"> 1. 1 Day: schedule a command for the week. 2. 3 Day: schedule commands for Weekdays, Saturdays, and Sundays. 3. 7 Day: schedule commands for each day of the week. |

* To choose this option you must set up the Time settings in the Configuration menu.

Note If there is a SH Demand signal during combi pre-heat, the space heating will take priority.

External Recirculation

When using the External Recirculation feature, you can choose commands in the menu to preheat according to the set DHW temperature.

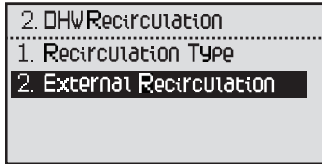

| Item | Description |
|-----------------------|---|
| 1. Always On | Set to repeat DHW Recirculation. |
| 2. Intelligent* | Set to detect DHW use for a week and repeat the detected cycle. |
| 3. Weekly* | The user can choose commands for DHW Recirculation on a weekly basis. 1. 1 Day: schedule a command for the week. 2. 3 Day: schedule commands for Weekdays, Saturdays, and Sundays. 3. 7 Day: schedule commands for each day of the week. |
| 4. Aquastat | Set to use an aquastat for DHW Recirculation. |
| 5. HotButton (Manual) | Set to use additional installations (HotButton) for Recirculation. |

*To choose this option you must set up the Time settings in the Configuration menu.

Note If there is a SH Demand signal during external recirculation, pre-heating will take priority, and space heating will start afterwards.

When Installing the Cascade System

When using the recirculation feature in the cascade system, you can choose commands in the menu to preheat according to the set DHW temperature. (Refer to "8.2 Cascade System - Recirculation System Application Example" for details on installing.)

Note For water heater(s) that are connected to the recirculation line, each unit must be set to the proper recirculation mode.



| Item | Description |
|--------------|---|
| 1. Always On | Set to repeat DHW Recirculation (default). |
| 2. Weekly* | The user can choose commands for DHW Recirculation on a weekly basis. 1. 1 Day: Schedule a command for the week. 2. 3 Day: Schedule commands for Weekdays, Saturdays, and Sundays. 3. 7 Day: Schedule commands for each day of the week. |

*To choose this option you must set up the Time setting in the Configuration menu.

Set the Weekly Schedule

When setting up the Weekly option, select 'Weekly,' and select between 1 Day, 3 Day, and 7 Day to go to the Schedule menu.

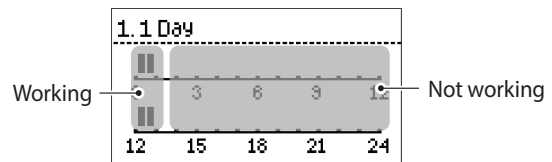

Rotate the Command Dial (⊗) to choose the scheduled time. You can choose the time in 30 minutes intervals. To finalize the weekly schedule settings, press and hold the Command dial (⊗) for more than 2 seconds.

11.3.5 Viewing Error History

To view the error history, press the Menu button (M), and then select "5. Error History".

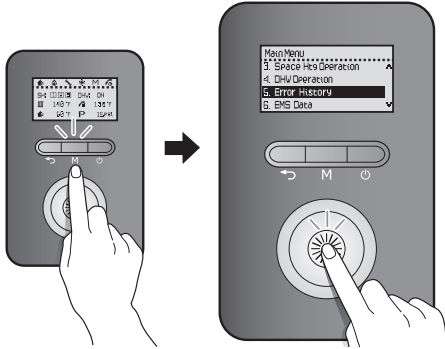

A list of 10 recent errors are displayed on the screen, with the most recent error displayed at the top of the list.



Rotate the Command dial (⊙) to switch between the list of errors. Press the Command dial (⊙) to select an error to view detailed information.

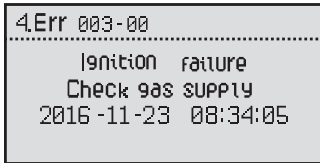

Press the Back button (←) to return to the previous screen or menu.

Note

- The front panel display flashes in red and the error icon is displayed (flashing) when a level 1 error is detected. You can press the Command dial (⊙) to enter error display mode. Boiler operation is maintained during a level 1 error.
- A level 1 error is automatically cleared when the problem is resolved.
- You can press the power button to clear a level 1 error. Then the error is cleared if the problem has been resolved.

11.3.6 Viewing Other System Information

To view the miscellaneous system information, press the Menu button (M), and then select "6. EMS Data".

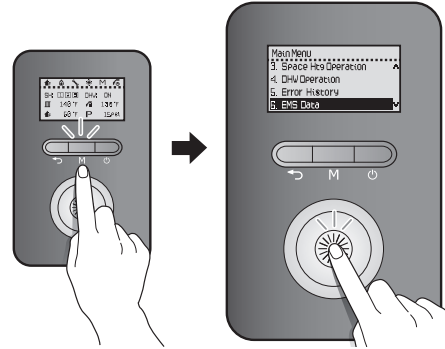

Rotate the Command dial (⊙) to switch between the information items. Press the Command dial (⊙) to select an item and view the information.

Press the Back button (←) to return to the previous screen or menu.

| Item | Description |
|-----------------------|--|
| 1. SH Operation Time | View monthly space heating operation logs. |
| 2. DHW Operation Time | View monthly DHW operation logs. |
| 3. Gas Consumption | View monthly gas consumption. |

11.3.7 Setting the Display Options

To set the front panel display options, press the Menu button (M), and then select "7. Configuration".

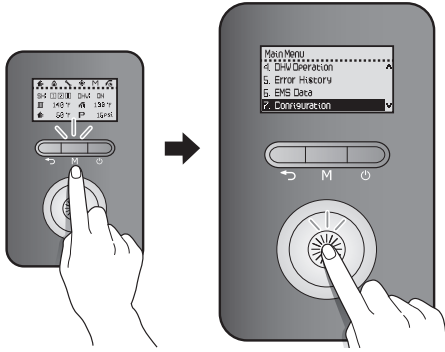

Rotate the Command dial (⊙) to switch between the list items or to increase/decrease setting values. Press the Command dial (⊙) to select an item or to confirm after making changes.

Press the Back button (←) to return to the previous screen or menu.

| Item | Description |
|---------------------------|---|
| 1. Language | Select a display language. 1. English 2. French • Default: English |
| 2. °C/°F Setting | Select a temperature unit. 1. Celsius (°C) 2. Fahrenheit (°F) • Default: Fahrenheit (°F) |
| 3. PSI/BAR Setting | Select a water pressure unit. 1. PSI 2. BAR • Default : PSI |
| 4. Time Setting | Set the system clock (RTC). • Display format: YYYY.MM.DD / HH:MM:SS |
| 5. Backlight Time Setting | Set the Backlight On time. • Setting range: 0 – 60 sec • Default: 2 sec |

11.4 Accessing Advanced Menu Items

11.4.1 Viewing Service Information

To view service information about the boiler, press the Back button (←) and the Menu button (M) simultaneously for 3 seconds, and then select "1. Service Status Info".

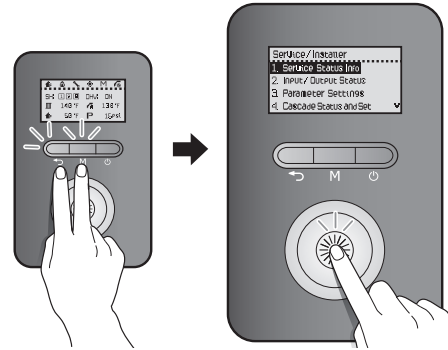

Rotate the Command dial (⊙) to switch between the information items. Press the Command dial (⊙) to select an item and view the information.

Press the Back button (←) to return to the previous screen or menu.

| Item | Description |
|------------------------------------|---|
| 1. Elapsed Time After Install | Elapsed time since installation |
| 2. HEX Overheat - No. of Times | Number of times the heat exchanger overheat protection has activated |
| 3. Flame Loss - No. of Times | Number of times a flame loss/misfire has occurred |
| 4. 2nd ignition - No. of Times | Number of second ignition attempts |
| 5. 3rd ignition - No. of Times | Number of third ignition attempts |
| 6. 4th ignition - No. of Times | Number of fourth ignition attempts |
| 7. 5 ~10th ignition - No. of Times | Number of tenth ignition attempts |
| 8. ΔT Limit - No. of times | Number of times supply return temperature limit control has activated. |
| 9. Supply Limit - No. of times | Number of times Recirculation supply temperature limit control has activated. |
| 10. ΔT High - No. of times | Number of times combustion stopped due to supply return temperature. |

11.4.2 Viewing Input and Output Status

To view the boiler's input and output status, press the Back button (↶) and the Menu button (M) simultaneously for 3 seconds, and then select "2. Input/Output Status".

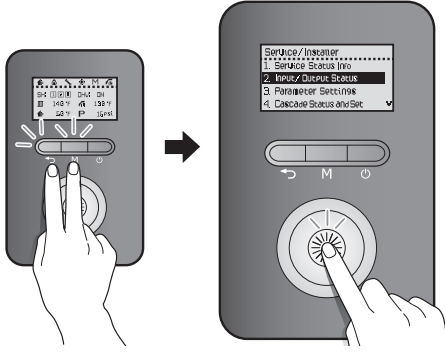

Rotate the Command dial (⊙) to switch between the information items. Press the Command dial (⊙) to select an item and view the information.

Press the Back button (↶) to return to the previous screen or menu.

| Item | Description |
|-----------------------------|--|
| 1. SH1 Thermostat Status | Space heating thermostat 1 input status |
| 2. SH2 Thermostat Status | Space heating thermostat 2 input status |
| 3. SH3 Thermostat Status | Space heating thermostat 3 input status |
| 4. Recirc. Input Status | External Recirculation thermostat input status |
| 5. Boiler Pump Status | Boiler pump output status |
| 6. Zone1 Pump Status | Zone 1 pump output status |
| 7. Zone2 Pump Status | Zone 2 pump output status |
| 8. Zone3 Pump Status | Zone 3 pump output status |
| 9. 3 way V/V Status | 3 way V/V output status |
| 10. Fill Valve Status | AWS V/V output status |
| 11. Ext Recirc. Pump Status | External Recirculation pump output status |
| 12. HTL Input Status | HTL input status |
| 13. Dual Venturi Status | Dual Venturi output status |

| Item | Description |
|---|-------------------------------------|
| 14. LWCO Input Status | LWCO input status |
| 15. Air Handler Interface Output Status | Air Handler Interface output status |

11.4.3 Setting the Operation Parameters

To set the boiler's operation parameters, press the Back button (↶) and the Menu button (M) simultaneously for 3 seconds, and then select "3. Parameter Settings".

! CAUTION

Parameters must be set by a qualified professional with an extensive understanding of the boiler system. Setting parameters improperly may lead to property damage or injury.

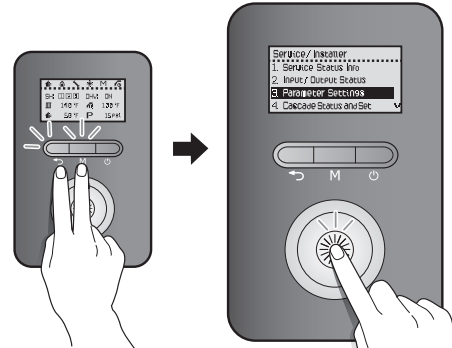

In the password screen, rotate the Command dial (⊙) to change numbers and places, and press the Command dial (⊙) to enter the password.

The factory default password is "1234".



After entering the parameter setting screen, rotate the Command dial (🌀) to switch between the parameters or to increase/decrease setting values. Press the Command dial (🌀) to select a parameter or to confirm after making changes.

Press the Back button (⏪) to return to the previous screen or menu.

| Item | Description |
|-------------------------|---|
| 1. Supply MIN Set-point | Set the space heating supply minimum temperature. <ul style="list-style-type: none"> Setting range: 77°F (25°C) – [MAX Set-point – 36°F (20°C)] Default: 104°F (40°C) |
| 2. Supply MAX Set-point | Set the space heating supply maximum temperature. <ul style="list-style-type: none"> Setting range: [MIN Set-point + 36°F (20°C)] – 194°F (90°C) Default: 180°F (82°C) |
| 3. Return MIN Set-point | Set the space heating return minimum temperature. <ul style="list-style-type: none"> Setting range: 68°F (20°C) – [MAX Set-point – 18°F (10°C)] Default: 86°F (30°C) |
| 4. Return MAX Set-point | Set the space heating return maximum temperature. <ul style="list-style-type: none"> Setting range: [MIN Set-point + 18°F (10°C)] – 158°F (70°C) Default: 149°F (65°C) |
| 5. SH Burner Off Diff | Set the temperature range to turn off space heating. <ul style="list-style-type: none"> Setting range: 2°F (1°C) – 54°F (30°C) Default: 4°F (2°C) |
| 6. SH Burner On Diff | Set the temperature range to turn on space heating. <ul style="list-style-type: none"> Setting range: -2°F (1°C) – 54°F (30°C) Default: 5°F (3°C) |
| 7. SH Min Limit | Set space heating minimum heat capacity limit. <ul style="list-style-type: none"> Setting range: Space heating Min capacity (%) – [space heating min capacity limit -20] % Default: Boiler's minimum heat capacity |

| Item | Description |
|-------------------------------|--|
| 8. SH Max Limit | Set space heating maximum heat capacity limit. <ul style="list-style-type: none"> Setting range: (Space heating Min capacity limit +20) % – 100% Default: 100% |
| 9. SH Min Burning Time | Set the low-load combustion time at initial operation. <ul style="list-style-type: none"> Setting range: 1 – 20 min Default: 1 min |
| 10. Burning Acceleration Time | Set the time to reach the maximum space heating capacity after initial operation. <ul style="list-style-type: none"> Setting range: 0 – 20 min Default: 1 min |
| 11. Anti Fast Cycling Time* | Set the anti-fast cycling time. <ul style="list-style-type: none"> Setting range: 0 – 20 min Default: 3 min |
| 12. DHW Min Limit | Set the DHW supply minimum temperature. <ul style="list-style-type: none"> Setting range: DHW minimum capacity (%) – [DHW MAX capacity limit - 20] % Default: Boiler's minimum heat capacity |
| 13. DHW Max Limit | Set the DHW supply maximum temperature. <ul style="list-style-type: none"> Setting range: [DHW Min capacity limit + 20] % – 100% Default: 100% |
| 14. Freeze protection | Set the pump freeze protection temperature. <ul style="list-style-type: none"> Setting range: 43°F (6°C) – 50°F (10°C) Default: 50°F (10°C) <p>Note The system freeze protection temperature is set based on the pump freeze protection temperature.</p> |
| 15. Auto-Fill Pressure | Set the Auto-Fill Pressure. <ul style="list-style-type: none"> Setting range: 12 - 50 psi Default: 12 psi |
| 16. High Sys Pressure | Set the high system water pressure. <ul style="list-style-type: none"> Setting range: 40 – 80 psi Default: 50 psi |

| Item | Description |
|-------------------------------|---|
| 17. Boiler Pump Delay** | Set the space heating pump over-run time. <ul style="list-style-type: none"> Setting range: 3 – 40 min Default: 40 min |
| 18. DHW Wait Time | Set the DHW wait time. <ul style="list-style-type: none"> Setting range: 0 – 20 min Default: 3 min |
| 19. Recirc. Interval Time | Set the recirculation or HotButton operation time. <ul style="list-style-type: none"> Setting range: 1 – 120 min Default: 20 min |
| 20. Recirc. Sampling Time | Set the recirculation interval time. <ul style="list-style-type: none"> Setting range: 1 – 120 min Default: 30 min |
| 21. Recirc. Off Diff. Temp | Set the temperature range to turn off recirculation or HotButton operation. <ul style="list-style-type: none"> Setting range: 5°F (3°C) – 54°F (30°C) Default: 9°F (5°C) |
| 22. Fixture Dist. (HotButton) | Set On-Demand recirculation to activate according to pipe length when HotButton is installed, and Thermal Bypass and external surface thermometer is disabled. <ul style="list-style-type: none"> Setting range: 15 ft (4.5 m) – 660 ft (198 m) (5 ft (1.5 m) intervals) Default: 30 ft (9 m) |
| 23. Service Notif Time | Set the time for service notification. <ul style="list-style-type: none"> Setting range: 30 – 3650 days (10 years) It can be set in 10 day increments. Default: 1820 days (5 years) |
| 24. Service Notif Cycl | Set the service notification according to the operating times. <ul style="list-style-type: none"> Setting range: 300 – 36500 cycles It can be set in 100 cycle increments. Default: 18200 cycles |
| 25. Service contact # | View the service contact information. |
| 26. Factory Reset | Initialize all parameter settings (panel and main controller) to factory default. |
| 27. P/W Change | Change the parameter setting password. Rotate the Command dial (⦿) to change numbers and places, and press the Command dial (⦿) to save the new password. |

Note

- If you enter an incorrect password 10 times or no input from the front panel display for 5 minutes, the boiler will return to Normal mode.
- To return to the previous mode, press the Reset button.
- The Factory default password is “1234”.
- If you make no inputs for 10 seconds in the Parameter Edit mode, the current parameter value will be saved automatically.
- Press and hold the Back button (↩) in Parameter Edit mode for 5 seconds to reset individual parameters to their default values.
- When you reset one of the following parameters, the corresponding parameter will be reset automatically:
 - Supply Min or Max capacity limit
 - Return Min or Max capacity limit

* The anti-fast cycling time is the duration that the boiler stops its space heating operation when the space heating supply or return temperatures reach the set values for boiler operation stop temperatures. The boiler will not resume space heating until the duration elapses, even when the space heating supply or return temperatures return to within the set ranges.

**Boiler Pump Delay is the duration the circulation pump continues to run between the space heating supply or return temperature reaching the set point and the burner turning off. If the space heating supply or return temperature remains outside of the boiler operation temperature range for a set period, the pump stops for 10 mins, runs again for 5 mins, and then repeats the cycle.

11.4.4 Configuring a Cascade System

To view and configure the cascade settings, press the Back button (↩) and the Menu button (M) simultaneously for 3 seconds, and then select “4. Cascade Status and Set”.

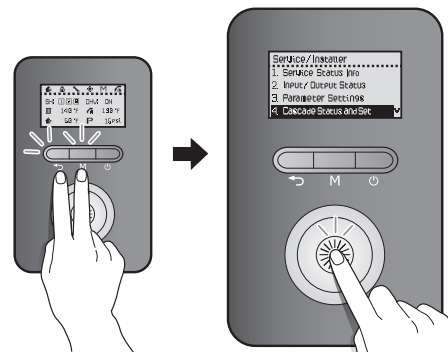

Rotate the Command dial (⦿) to switch between the parameters or to increase/decrease setting values. Press the Command dial (⦿) to select a parameter or to confirm after making changes.

Press the Back button (↶) to return to the previous screen or menu.

| Item | Description |
|--------------------------------|---|
| 1. Cascade System Setting | <ul style="list-style-type: none"> To enter the Cascade Main setting mode, select Start. The setting mode is entered and the IDs of all boilers that can communicate with the Main via the RS485 communication line are initialized. The boilers whose IDs are initialized by the Main are set to <Sub setting mode>, if you press the OK button for 2 seconds or more, the Main gives you the ID and it is displayed on the screen. The Main periodically checks the RS485 communication, and when there is an ID request from the Sub, the ID is sequentially incremented and added to the Sub (1 to 16). Select OK in the Main to complete the cascade setting, and the Main and the assigned Sub IDs will return to <Normal operation mode> and turn into CASCADE ON state. At this time, the Main icon on the Main panel lights up. If the cascade setting is idle for more than 1 hour, it returns to <Normal operation mode> and reverts to CASCADE OFF state automatically. |
| 2. Cascade System Removal | <p>Select this option on the Main unit of a cascade system to end cascade operation.</p> <ul style="list-style-type: none"> Enter Cascade system setting mode to reassign IDs and begin a cascade system again. If a Sub unit has a network communication problem, select this option on the Sub unit to exclude the individual unit from the cascade system. |
| 3. Cascade Init-operation Unit | <p>Set the initial number of activated boilers.</p> <ul style="list-style-type: none"> Setting range: 0 – 16 Default: 0 |
| 4. Cascade Protocol | <p>Set the cascade protocol.</p> <ul style="list-style-type: none"> NPE or NR Default : NPE |
| 5. Number of Oper-Unit | <p>The number of units currently operating in the cascade system.</p> |

| Item | Description |
|----------------------|--|
| 6. Cascade Info. | View the operating status of individual units in the cascade system. |
| 7. Vent Type Setting | <p>Set the type of ventilation.</p> <ul style="list-style-type: none"> Default: Common vent |

11.4.5 Setting the External Connection (for Navilink)

To view and configure the external network connection, press the Back button (↶) and the Menu button (M) simultaneously for 3 seconds, and then select "5. External Connection".

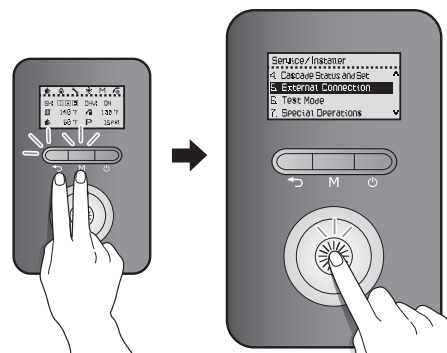

Rotate the Command dial (⊙) to switch between the parameters or to increase/decrease setting values. Press the Command dial (⊙) to select a parameter or to confirm after making changes.

Press the Back button (↶) to return to the previous screen or menu.

| Item | Description |
|---------------------|---|
| 1. Navilink Connect | <p>Turn on or turn off the remote control capabilities via the Navilink connection.</p> <ul style="list-style-type: none"> Setting range: On/Off Default: Off |

11.4.6 Diagnosing the Boiler System

To run a series of test procedures for a system diagnosis, press the Back button (↶) and the Menu button (M) simultaneously for 3 seconds, and then select "6. Test Mode".

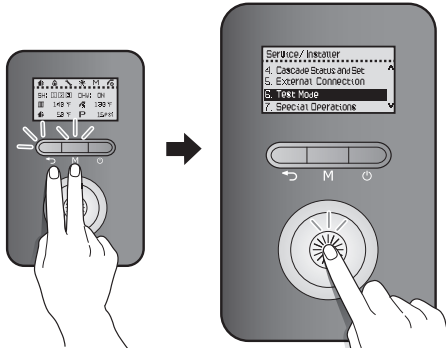

Rotate the Command dial (☀) to switch between the test procedures. Press the Command dial (☀) to run a test procedure.

Press the Back button (↶) to return to the previous screen or menu.

| Item | Description |
|----------------|--|
| 1. Fan Motor | <p>Test the fan operation by manually changing the fan speed.</p> <ul style="list-style-type: none"> From a stopped state, the fan speed gradually increases and reaches the top speed, and then the fan speed decreases until the fan stops operating. Rotate the Command dial (☀) to run or stop the fan test. |
| 2. Boiler Pump | <p>Test the boiler pump operation.</p> <ul style="list-style-type: none"> The boiler pump is turned on as soon as you enter the test mode. Press the Command dial (☀) to toggle the pump operation (On -> Off / Off -> On). |
| 3. Zone 1 Pump | <p>Test the Zone 1 pump operation.</p> <ul style="list-style-type: none"> The Zone 1 pump is turned on as soon as you enter the test mode. Press the Command dial (☀) to toggle the pump operation (On -> Off / Off -> On). |

| Item | Description |
|------------------------------|---|
| 4. Zone 2 Pump | <p>Test the zone 2 pump operation.</p> <ul style="list-style-type: none"> The zone 2 pump is turned on as soon as you enter the test mode. Press the Command dial (☀) to toggle the pump operation (On -> Off / Off -> On). This option is available only when the "Zone Pump System" is active. |
| 5. Zone 3 Pump | <p>Test the Zone 3 pump operation.</p> <ul style="list-style-type: none"> The Zone 3 pump is turned on as soon as you enter the test mode. Press the Command dial (☀) to toggle the pump operation (On -> Off / Off -> On). |
| 6. 3 Way Valve Output | <p>Test the 3 Way valve operation.</p> <ul style="list-style-type: none"> The 3 Way valve is turned on as soon as you enter the test mode. Press the Command dial (☀) to toggle the valve operation (On -> Off / Off -> On). |
| 7. Flow Control Valve Output | <p>Test the Flow control valve operation. Rotate the valve from its current position to fully open (0%), then fully closed (100%) and then back to the starting position while checking feedback.</p> <ul style="list-style-type: none"> Display of the valve close ratio % Display of "FEEDBACK" when detecting the feedback |
| 8. Mixing Valve Output | <p>Test the Mixing valve operation. Rotate the valve from its current position to fully open (0%), then fully closed (100%) and then back to the starting position while checking feedback.</p> <ul style="list-style-type: none"> Display of the valve close ratio % Display of "FEEDBACK" when detecting the feedback |
| 9. Dual Venturi | <p>Test the dual venturi operation.</p> <ul style="list-style-type: none"> The dual venturi is turned on as soon as you enter the test mode. Press the Command dial (☀) to toggle the dual venturi operation (On -> Off / Off -> On). |
| 10. Recirc. Pump | <p>Test the recirculation pump.</p> <ul style="list-style-type: none"> The recirculation pump is turned on as soon as you enter the test mode. Press the Command dial (☀) to toggle the recirculation pump (On -> Off / Off -> On). |

11.4.7 Setting the Special Operation Modes

To operate the boiler in special operation modes, press the Back button (↩) and the Menu button (M) simultaneously for 3 seconds, and then select "7. Special Operations".

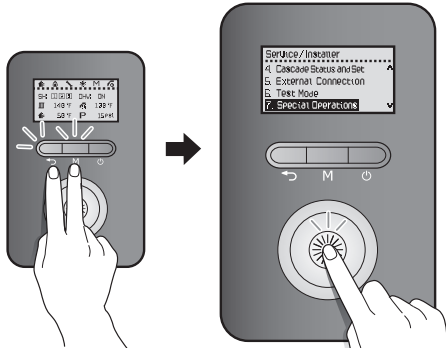

Rotate the Command dial (⊙) to switch between the operation modes. Press the Command dial (⊙) to select an operation mode.

The boiler resumes operation in normal operation mode if no input is detected for 3 hours.

Press the Back button (↩) to return to the previous screen or menu.

| Item | Description |
|----------------|--|
| 1. Normal | Set the boiler to run in Normal operation mode. |
| 2. 1st MIN | Set the boiler to run in 1st stage minimum operation mode. |
| 3. DHW 1st MAX | Set the boiler to run in DHW 1st maximum operation mode. |
| 4. 2nd MIN | Set the boiler to run in 2nd stage minimum operation mode. |
| 5. DHW 2nd MAX | Set the boiler to run in DHW 2nd maximum operation mode. |
| 6. SH 1st MAX | Set the boiler to run in SH 1st maximum operation mode. |
| 7. SH 2nd MAX | Set the boiler to run in SH 2nd maximum operation mode. |

11.4.8 Operating in Air Purge Mode

To operate the boiler in air purge mode, press the Back button (↩) and the Menu button (M) simultaneously for 3 seconds, and then select "8. Air Purge Mode".

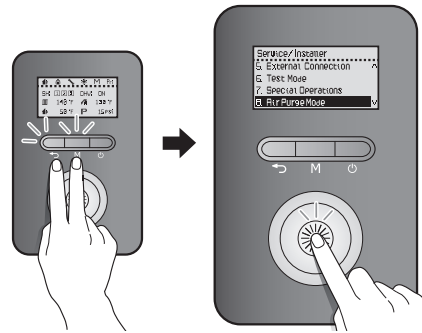

Rotate the Command dial (⊙) to switch between the parameters. Press the Command dial (⊙) to run an air purge.

The boiler resumes operation in normal operation mode if no input is detected for 15 minutes.

Press the Back button (↩) to return to the previous screen or menu.

| Item | Description |
|----------------------|---|
| 1. SH pipe air purge | Run an air purge on the space heating pipe. |

11.5 Understanding Error Codes

When an error code appears on the front panel, refer to the following chart for a definition and possible remedy for the situation.

| Error Code | Reason | Self-Diagnostic/ Action |
|------------|--|---|
| E001 | Heatexchanger over temperature | Reset the boiler from the front panel. |
| E003 | Ignition failure | Ensure that the main gas supply valve is open. |
| E004 | False flame detection | Ensure that the electrical cord is properly grounded. |
| E012 | Flame loss | <ul style="list-style-type: none"> • Clean the intake air filter. • Ensure that the electrical cord is properly grounded. |
| E016 | Overheating of heat exchanger | <ul style="list-style-type: none"> • Turn off the system for at least 30 minutes, and then restart it. • Flush the heat exchanger. |
| E030 | Abnormal exhaust temperature | Contact technical support at 1-800-519-8794. |
| E031 | Overheating of burner | Contact technical support at 1-800-519-8794. |
| E046 | Abnormal operation: limit control | Contact technical support at 1-800-519-8794. |
| E047 | Abnormal operation: exhaust thermostat | Contact technical support at 1-800-519-8794. |
| E060 | Abnormal operation: dual venturi | Contact technical support at 1-800-519-8794. |
| E109 | Abnormal operation: fan motor | Clean the intake air filter. |
| E110 | Abnormal air pressure | <ul style="list-style-type: none"> • Ensure that the exhaust pipe is free of obstructions. • Clean the intake air filter. |
| E205 | Heating supply thermistor open or short circuit | Contact technical support at 1-800-519-8794. |
| E218 | Heating return thermistor open or short circuit | Contact technical support at 1-800-519-8794. |
| E278 | Abnormal operation: system supply thermistor | Contact technical support at 1-800-519-8794. |
| E279 | Abnormal operation: system return thermistor | Contact technical support at 1-800-519-8794. |
| E351 | Abnormal Auto feeder valve (make-up water) | Contact technical support at 1-800-519-8794. |
| E352 | High water pressure | Contact technical support at 1-800-519-8794. |
| E353 | Abnormal operation: water pressure sensor | Contact technical support at 1-800-519-8794. |
| E407 | Hot water outlet: thermistor open or short circuit | Contact technical support at 1-800-519-8794. |
| E421 | Cold water inlet: thermistor open or short circuit | Contact technical support at 1-800-519-8794. |
| E434 | Abnormal operation: water adjustment valve | Contact technical support at 1-800-519-8794. |
| E439 | Abnormal operation: flow sensor | Contact technical support at 1-800-519-8794. |
| E441 | Hot water outlet 2: thermistor open or short circuit | Contact technical support at 1-800-519-8794. |
| E445 | Abnormal operation: Bypass mixing valve | Contact technical support at 1-800-519-8794. |
| E515 | Abnormal operation: PCB | <ul style="list-style-type: none"> • Ensure that the electrical cord is properly grounded. • Reset the boiler from the front panel. |
| E517 | Abnormal operation: Dip switch setting | Contact technical support at 1-800-519-8794. |
| E594 | Abnormal operation: EEPROM | Contact technical support at 1-800-519-8794. |

| Error Code | Reason | Self-Diagnostic/ Action |
|------------|--|--|
| E615 | Abnormal operation: input and memory | Contact technical support at 1-800-519-8794. |
| E736 | Abnormal operation: cascade communication | Contact technical support at 1-800-519-8794. |
| E740 | Abnormal operation: outdoor temperature sensor (appears only when the outdoor reset curve is enabled). | <ul style="list-style-type: none"> • Ensure that the outdoor reset curve is configured properly. • Check the outdoor temperature sensor wiring connection. |
| E761 | Abnormal operation: Pre-Heat Aquastat | <ul style="list-style-type: none"> • Check the Pre-Heat Aquastat wiring connection. • Select an option other than Aquastat mode. |
| E777 | LWCO (service code: 7700) (external device) | <ul style="list-style-type: none"> • Check the LWCO wiring connection. • Ensure that the system water level is appropriate. • Add make-up water to the system if necessary. |
| E782 | Abnormal operation: main panel communication | Contact technical support at 1-800-519-8794. |
| E784 | Abnormal operation: zone controller communication | Contact technical support at 1-800-519-8794. |

If any of these remedies do not resolve the problem, contact Technical Support at 1-800-519-8794.

12. Appendixes

12.1 Gas & High Altitude Conversion

This boiler is configured for Natural Gas at the factory.

- If conversion to Propane Gas is required by the boiler, use the LP CONVERSION KIT supplied with the boiler.
- If the boiler is installed at a high altitude (above 5,400 ft) for NG, use the HIGH ALTITUDE CONVERSION KIT supplied with the boiler.

- Note**
- For NG high altitude conversion, use the HIGH ALTITUDE CONVERSION KIT.
 - For LP high altitude conversion, use the LP CONVERSION KIT. Note that the Gas Orifice from the LP CONVERSION KIT covers the boiler's installation at an altitude of 0 to 10,100 ft.



WARNING

This conversion kit must be installed by a qualified service agency* in accordance with Navien's instructions and all applicable codes and requirements of the authority having jurisdiction. The information in these instructions must be followed to minimize the risk of fire or explosion or to prevent property damage, personal injury or death. The qualified service agency is responsible for the proper installation of this kit. The installation is not proper and complete until the operation of the converted appliance is checked as specified in the manufacturer's instructions supplied with the kit.

* A qualified service agency is any individual, firm, corporation or company which either in person or through a representative is engaged in and is responsible for the connection, utilization, repair or servicing of gas utilization equipment or accessories; who is experienced in such work, familiar with all precautions required, and has complied with all of the requirements of the authority having jurisdiction.

In Canada: The conversion shall be carried out in accordance with the requirements of the provincial authorities having jurisdiction and in accordance with the requirements of the CAN-B149.1 and CAN1-B149.2 Installation Code.

Tools Required:

- Phillips Screwdriver
- Flathead Screwdriver
- ⁵/₃₂ in or 4 mm Allen Wrench
- Combustion Analyzer or Dual Port Manometer
- Gas Leak Detector

Included Items:

- Gas Orifice (Table 1)
- Gas Pressure and Conversion Kit Number Labels

NFC-175/200 Orifice Identification



| Gas Type | NG | | LP |
|--------------|--|--|---|
| Altitude | 0-5,399 ft | 5,400-10,100 ft | 0-10,100 ft |
| Orifice |  Factory Installed |  For High altitude |  For LP |
| Orifice Size | Ø6.1/Ø6.6 | Ø6.3/Ø6.8 | Ø4.5/Ø4.9 |

Table 1. Orifice Size



WARNING

- Be careful not to confuse the LP CONVERSION KIT and HIGH ALTITUDE CONVERSION KIT. Do NOT use the HIGH ALTITUDE CONVERSION KIT for NG when converting to LP gas.
- Make sure that the conversion is completed with the proper orifice. If the installed orifice does not conform to the specifications in Table 1, incomplete combustion may occur, resulting in personal injury or property damage.

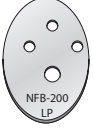
Procedure:

Note The procedure below can be applied to both LP conversion and High Altitude conversion. Distinguish the kit supplied with the boiler before installing.

1. Turn off both gas and water supply to the boiler.
2. Unfasten the 4 latches (2 at the top and 2 at the bottom) to remove the front cover and gain access to the internal components. See Figure 1 for illustration of the front cover clamps.

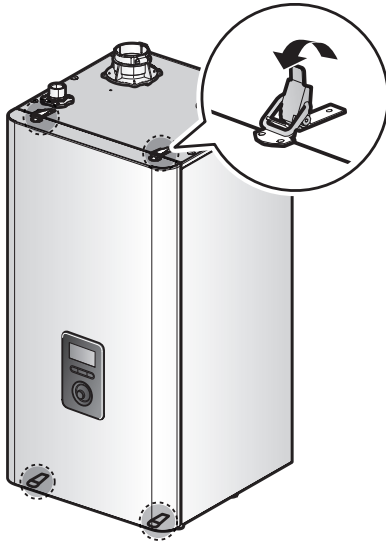

Figure 1. NFC Series Front cover

3. Remove the front cover and place it in a safe location to prevent accidental damage.

4. With the internal components exposed, locate the gas inlet pipe and the gas valve, as shown in Figure 2.

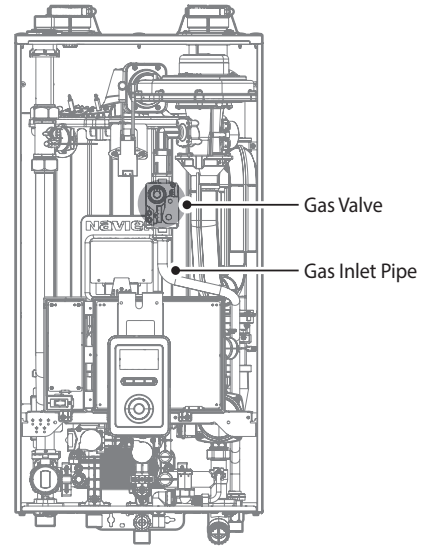

Figure 2. NFC Series Internal Components

5. Remove the clip at location A – the connection above the gas valve where it connects to the gas valve outlet adapter. See Figure 3 for reference.
6. Find location B - the connection above the gas valve where it is attached to the fan motor assembly. Carefully remove the four screws using a Phillips-head screwdriver and pull the gas valve outlet adapter away from the fan assembly to access the gas orifice.

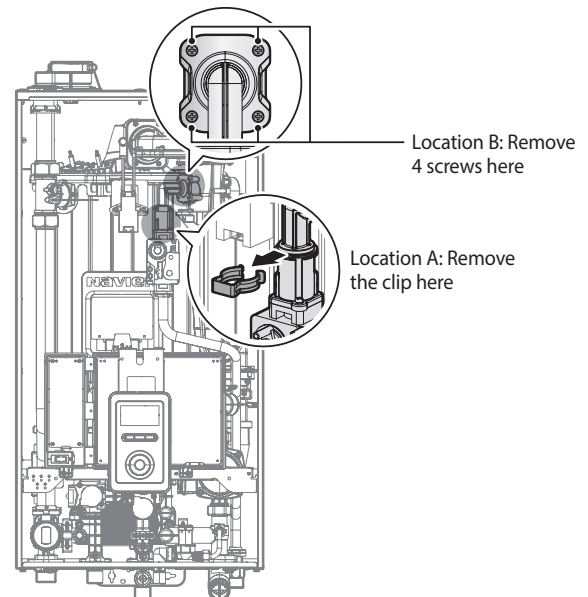

Figure 3. Detaching the Gas Valve Outlet Adapter from the Gas Valve and Fan Motor Assembly

7. Once the Gas Orifice is exposed, remove the two screws that hold the part in place. Remove the Gas Orifice from its housing and prepare the new Gas Orifice for the LP or High Altitude conversion for installation.

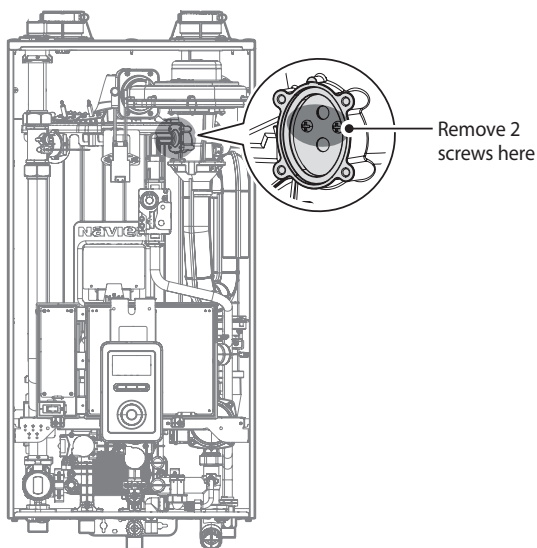

Figure 4. Access to Gas Orifice in Fan Assembly



WARNING

- DO NOT adjust or attempt to measure gas valve outlet pressure. The gas valve is factory-set for the correct outlet pressure. This setting is suitable for natural gas and propane, requiring no field adjustment.
- Attempting to alter or measure the gas valve outlet pressure could result in damage to the valve, causing potential severe personal injury, death or substantial property damage. Navien NFC boilers are shipped ready to fire natural gas ONLY.

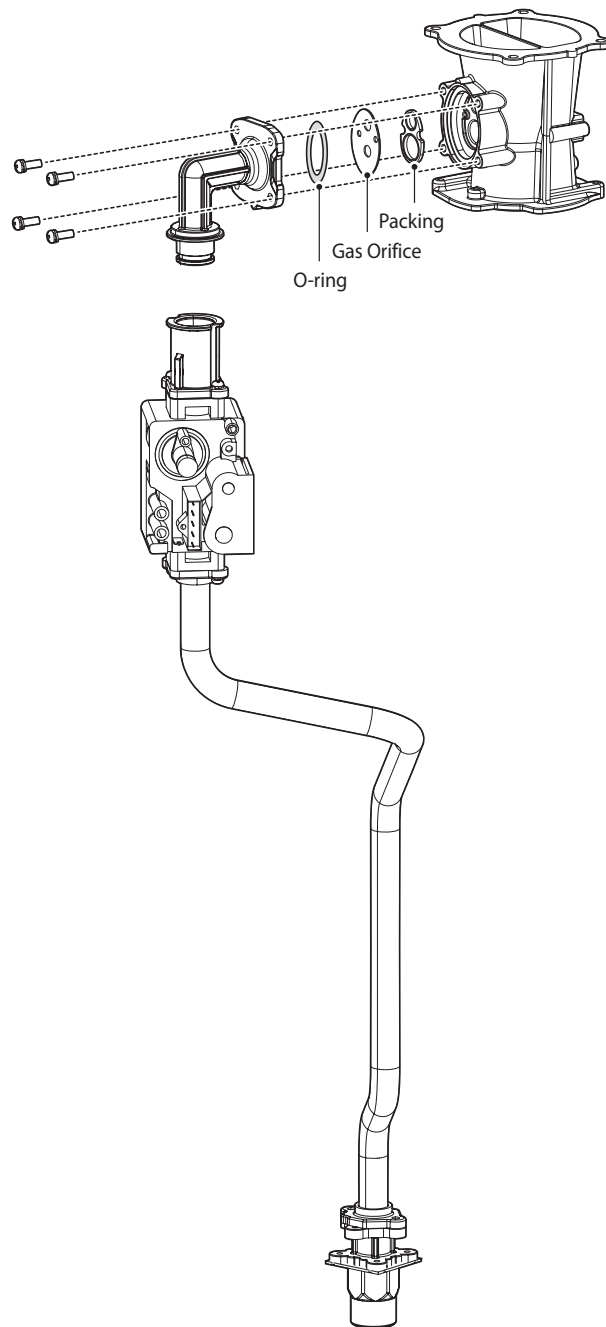
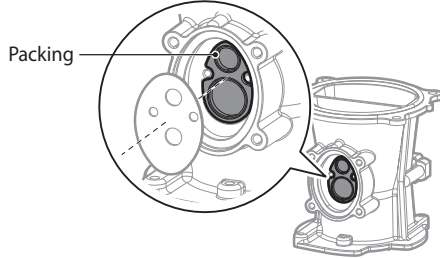

Figure 5. Exploded View of Gas Pipe Assembly

- Remove the Gas Orifice, ensure that the packing is properly seated inside the port, and then install the new Gas Orifice for use with LP gas. Ensure that the Orifice is properly seated on the packing inside the port before proceeding to the next step.



- Replace the gas valve outlet adapter to its original position and use all screws to secure all connections.

Note Do not overtighten as this may damage or crack the components.

- Set the PCB DIP switch to change the gas type. For LP, set Dip Switch 2 #1 to ON. For NG, set DIP SW2 #1 to OFF.

WARNING

Ensure that you have turned off the power to the boiler before accessing the DIP switches.

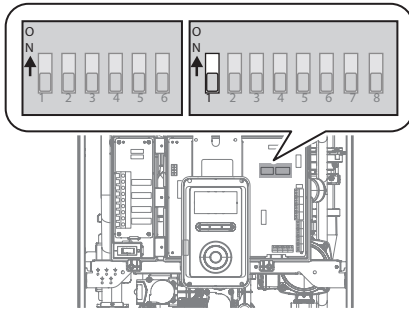

| Switch | Function | Setting | Comment |
|--------|---------------|--------------------------------|--------------|
| 1 | Gas Type | Natural Gas | 1-OFF |
| | | Propane Gas | 1-ON |
| 2&3 | High Altitude | 0-1,999 ft (0-609m) | 2-OFF, 3-OFF |
| | | 2,000-5,399 ft (610-1,645m) | 2-ON, 3-OFF |
| | | 5,400-7,699 ft (1,646-2,346m) | 2-OFF, 3-ON |
| | | 7,700-10,100 ft (2,347-3,078m) | 2-ON, 3-ON |

When applying the Gas Orifice for high altitude, set the PCB DIP switches by altitude according to the table above.

- Note**
- This unit may be installed at elevations up to 10,100 ft (3,078 m) for use with natural gas and propane. To use the unit at a specific altitude, the DIP Switches should be set as described above.
 - High Altitude: Above 2,000 ft (610 m), the unit will de-rate by 3% for each 1,000 ft (305 m) of altitude gain.
 - For NG, if you install the unit at above 5,400 ft (1,646 m), it is required to change the Gas Orifice for high altitude. Be careful not to confuse it with the Gas Orifice for LP.
 - Note that the Gas Orifice from the LP CONVERSION KIT covers the boiler's installation at an altitude of 0 to 10,100 ft.

CAUTION

Ensure that the High Altitude setting reflects the actual location of the boiler. If not, it may cause personal injury or malfunction of the boiler.

DANGER

- When conversion is required, be sure to set the PCB DIP switch 2 #1 according to the supply gas type.
- For NG, use the Gas Orifice for high altitude when the boiler is installed at above 5,400 ft, and be careful not to confuse it with the Gas Orifice for LP.
- For High Altitude conversion, check the DIP switches setting value by altitude before setting.
- Failure to properly set the DIP switches could cause carbon monoxide poisoning, resulting in severe personal injury or death.

- Turn on the gas and water supply to the boiler.

12. Measure and adjust the gas/air ratio.

Option 1. Using Combustion Analyzer (recommended)

- a. Loosen the screw, rotate the plate and remove the gasket to access the emissions monitoring port as shown in Figure 6.
- b. Insert the analyzer into the port (Figure 6).

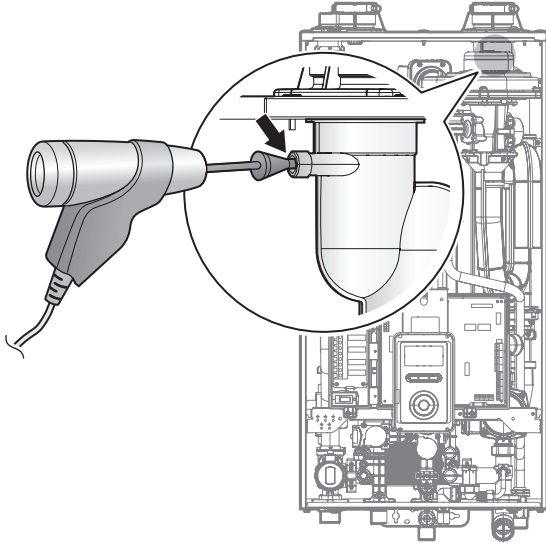
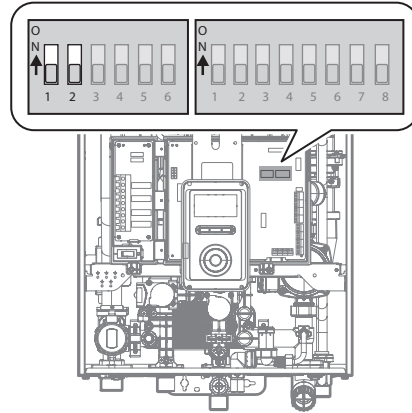

Figure 6. Insert the Analyzer

The DIP SW 1 on the circuit board configures the operation status and model/capacity settings.



| Switch | Function | Setting | |
|--------|------------------|------------------|--------------|
| 1 & 2 | Operation Status | Normal Operation | 1-OFF, 2-OFF |
| | | 2-stage MAX | 1-ON, 2-OFF |
| | | 1-stage MIN | 1-OFF, 2-ON |
| | | 1-stage MAX | 1-ON, 2-ON |
| 3 & 4 | Reserved | - | - |
| 5 & 6 | Model | NFC-200 | 5-OFF, 6-OFF |
| | | NFC-175 | 5-ON, 6-OFF |

| Model | Altitude | Fuel | High fire | Low fire |
|--------------------|-----------------|------|------------------|------------------|
| | | | %CO ₂ | %CO ₂ |
| NFC-175 NFC-200 | 0-5,399 ft | NG | 8.9 | 9.5 |
| | | LP | 10.2 | 10.8 |
| | 5,400-10,100 ft | NG | 8.5 | 9.5 |
| | | LP | 10.2 | 10.8 |

Table 2. CO₂ value
(CO₂ values must be within 0.5% of the values listed.)

- c. Activate multiple zones and set the boiler to operate at 1-stage MIN mode.

Note For operation mode selection, refer to “11.4.7 Setting the Special Operation Modes” on page 100.

Measure the CO₂ value at low fire.
If the CO₂ value is not within 0.5% of the value listed in Table 2, the gas valve set screw will need to be adjusted. If adjustment is necessary, locate the set screw as shown in Figure 7. Using a ⁵/₃₂ in or 4 mm Allen wrench, turn the set screw no more than 1/4 turn clockwise to raise or counterclockwise to lower the CO₂ value.

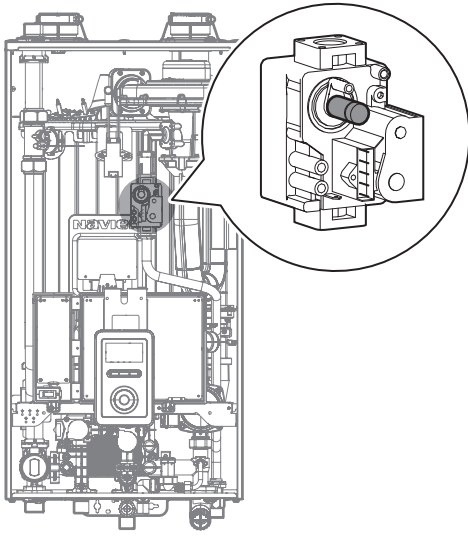

Figure 7. Set Screw Location

Note The set screw is located behind the screw-on cover. This must be removed first.

- d. Activate multiple zones and set the boiler to operate at 2-stage D. MAX mode (refer to “11.4.7 Setting the Special Operation Modes” on page 100). Measure the CO₂ value at high fire.

If the CO₂ values do not match Table 2 at high fire, do not adjust the gas valve. Check for the proper Gas Orifice.

! DANGER

Improper gas valve settings can cause severe personal injury, death or substantial property damage.

Option 2. Using Digital Manometer

- a. Open the offset pressure port by loosening the screw two turns as shown in Figure 8.

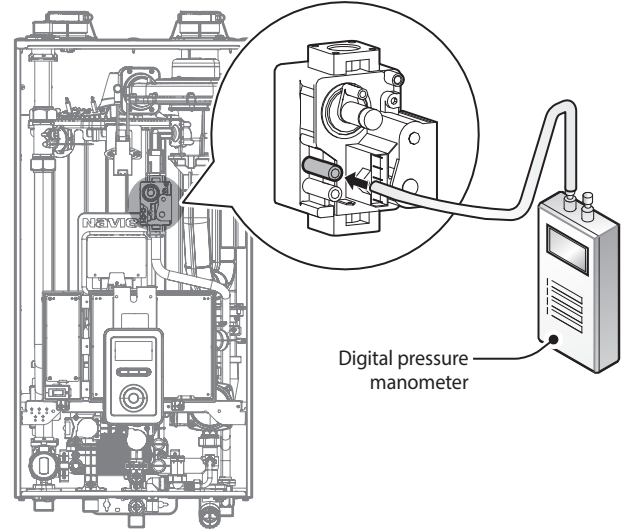

Figure 8. Connect Digital Pressure Monometer

- b. Connect a manometer to the offset pressure port. For dual port manometers, use the positive pressure side.

| Model | Altitude | Kit Part No. | Gas Type | Offset |
|--------------------|-----------------|--------------|----------|----------------------|
| NFC-175 NFC-200 | 0-5,399 ft | NAC-N200 | NG | -0.04 in ±0.01 in |
| | 5,400-10,100 ft | NAC-NCH200 | | |
| | 0-10,100 ft | NAC-LC200 | LP | -0.02 in ±0.01 in |

Table 3. Offset value for low fire

- c. Activate multiple zones and set the boiler to operate at 1-stage MIN mode (refer to “11.4.7 Setting the Special Operation Modes” on page 100). Measure the offset value at low fire and compare it to the values in Table 3. If the offset value is out of range, the gas valve set screw will need to be adjusted.

If adjustment is necessary, locate the set screw as shown in Figure 9. Using a $5/32$ in or 4mm Allen wrench, turn the set screw no more than $1/4$ turn clockwise to raise or counterclockwise to lower the offset value.

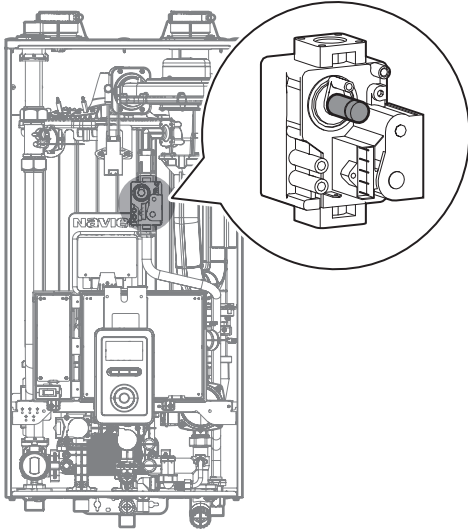

Figure 9. Set Screw Location

Note The set screw is located behind the screw-on cover. This must be removed first.

- d. At high fire, do not check the offset value and never adjust the gas valve.

! DANGER

Improper gas valve settings can cause severe personal injury, death or substantial property damage.

13. Once the CO₂ or offset values have been confirmed, apply the included conversion stickers to show that the appliance has been converted to Propane Gas or High Altitude. Place these labels adjacent to the rating plate as shown in Figure 10.

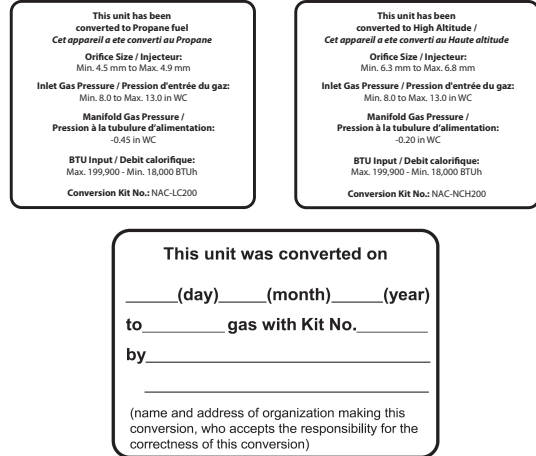
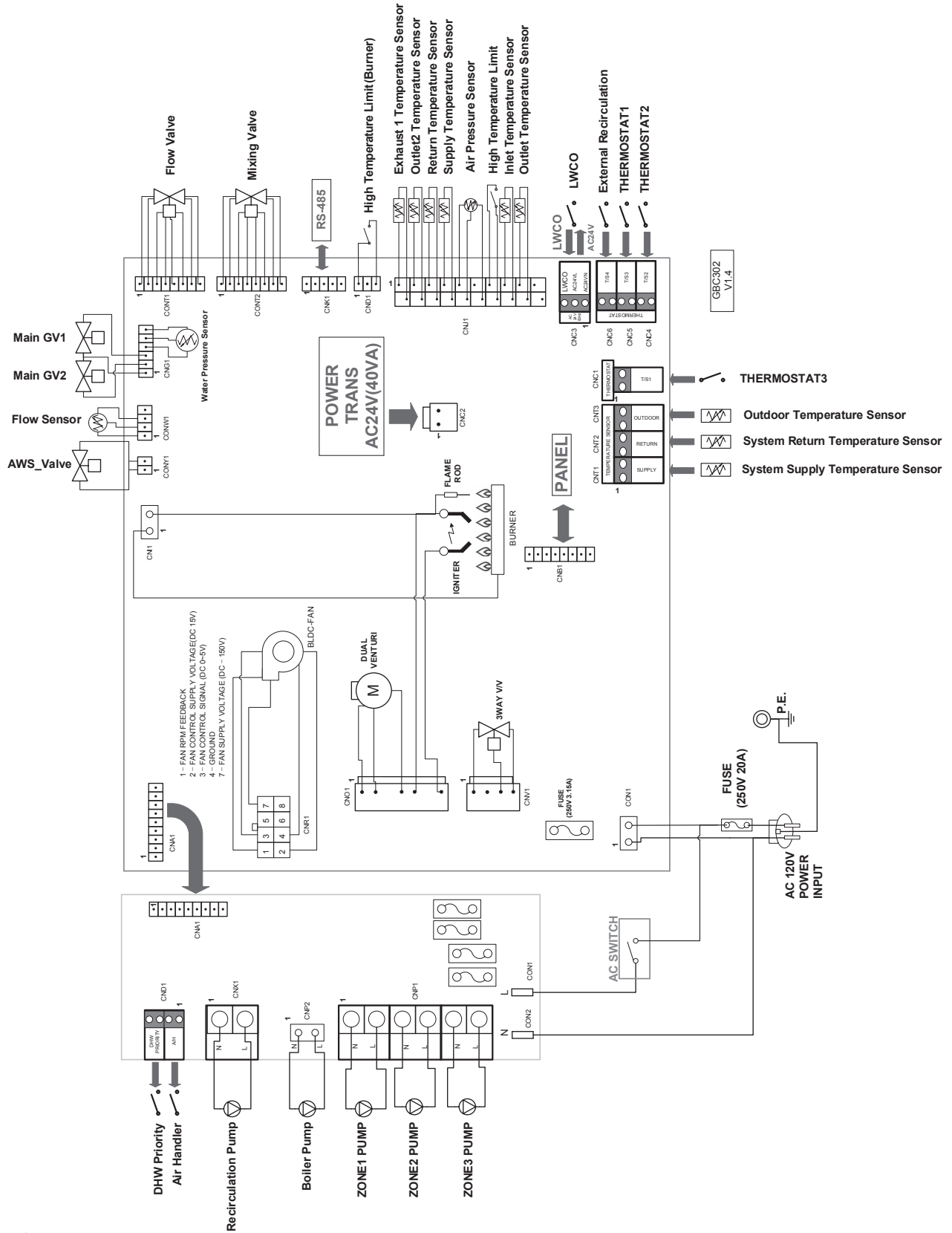

Figure 10. Proper Placement of Gas Conversion Labels

Note The gas conversion rating plate varies depending on the model. Check the conversion kit number before attaching the labels.

12.2 Wiring Diagram



12.3 Ladder Diagram

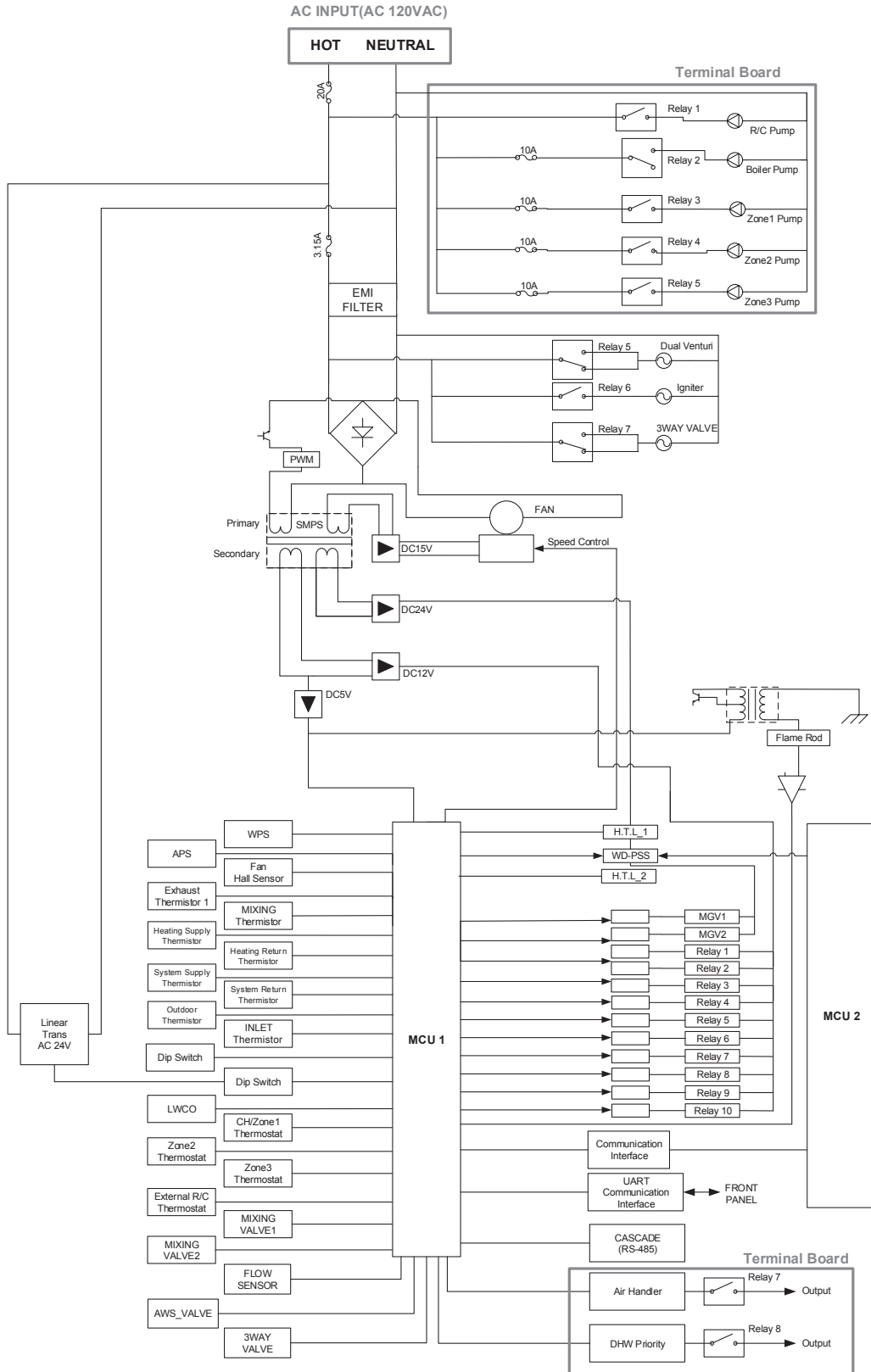

12.4 Outdoor Temperature Sensor

Outdoor Temperature Sensor Installation

1. Pull out the sensor body from the cap.
2. Attach the body to the wall using the screws/anchors provided with the appliance.
3. Run the wires into the appliance body through the grommet opening.
4. Connect the wires to the terminal block.
5. Attach the cap to the body.

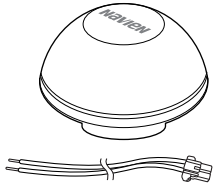

Navien Outdoor Temperature Sensor Kit

Outdoor Temperature Sensor Installation Guidelines

- Avoid areas with temperature fluctuations by direct sunlight, and where the temperature may not be representative of true outdoor temperature.
- Best location to install the temperature sensor is on a North or Northeast side of a structure under eaves where the sensor is shielded from direct sunlight.
- Avoid placing sensor in close proximity of heat sources that may affect correct temperature sending (fans, exhausts, vents, lights).
- Avoid installing the sensor in areas where the sensor is subjected to excessive moisture.
- Use 18 gauge wiring (thermostat wiring) with no splices (except at the unit harness connection with blue leader wire).
- Caution should be taken to avoid potential electromagnetic interference (EMI) by routing separately from potential sources such as line voltage wiring. When necessary, shielded cable may be used.
- Make sure wiring connections are secure before closing the cap.
- The sensor is a water resistant appliance.
- Any damage to the appliance may require the replacement of the entire component.

12.5 Outdoor Reset Control

The Outdoor Reset Control feature may be used to enhance energy efficiency while maintaining optimal heating performance. With the Outdoor Reset Control, the space heating temperature setting automatically changes according to the outdoor temperature and the current space heating system application (system load).

You can configure the Outdoor Reset Control settings on the front panel. Refer to "11.3.3 Setting the Space Heating Operation" on page 89 and "11.4.3 Setting the Operation Parameters" on page 95.

Note The Outdoor Reset Control feature requires installation of an outdoor temperature sensor, and it only works when the boiler is running in the normal operation mode. It does not work when the boiler is running in either the Minimum (MIN) or Maximum (MAX) mode, or when the boiler's front panel displays a fault.

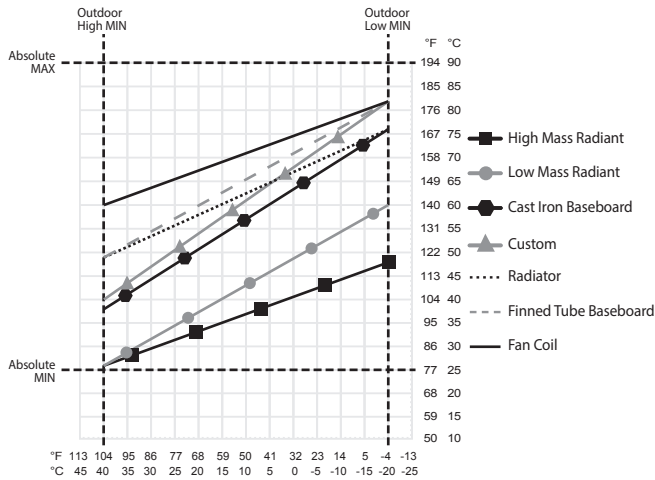

Space Heating Temperature Setting for the Outdoor Reset Control Feature

The following tables list the default space heating temperature range by system heat load and the applicable outdoor temperature ranges.

Outdoor Temperature Sensor Installation Guidelines

| Heat Load | Supply Set Point Range | Return Set Point Range |
|---------------------------------|-------------------------|-------------------------|
| Finned Tube Baseboard (default) | 120-180°F (48.5-82°C) | 101-147°F (38-63.5°C) |
| Fan Coil | 140-180°F (60-82°C) | 116-147°F (46.5-63.5°C) |
| Cast Iron Baseboard | 100-170°F (37.5-76.5°C) | 86-139°F (30-59°C) |
| Low Mass Radiant | 80-140°F (26.5-60°C) | 70-116°F (21-46.5°C) |
| High Mass Radiant | 80-120°F (26.5-48.5°C) | 70-101°F (21-38°C) |
| Radiators | 120-170°F (48.5-76.5°C) | 101-139°F (38-59°C) |
| Custom | 104-180°F (40-82°C) | 86-149°F (30-65°C) |

Outdoor Temperature Range and Default Temperature Settings

| Set Point | Range | Remarks |
|--------------------------|--|-----------------------|
| Outdoor Low Temperature | -4°F (-20°C) to Outdoor High Temperature Set Point - 9°F (5°C) | Default: 14°F (-10°C) |
| Outdoor High Temperature | Outdoor Low Temperature Set Point + 9°F (5°C) to 104°F (40°C) | Default: 70°F (21°C) |

12.6 Component Assembly Diagrams and Parts Lists

12.6.1 Case Assembly

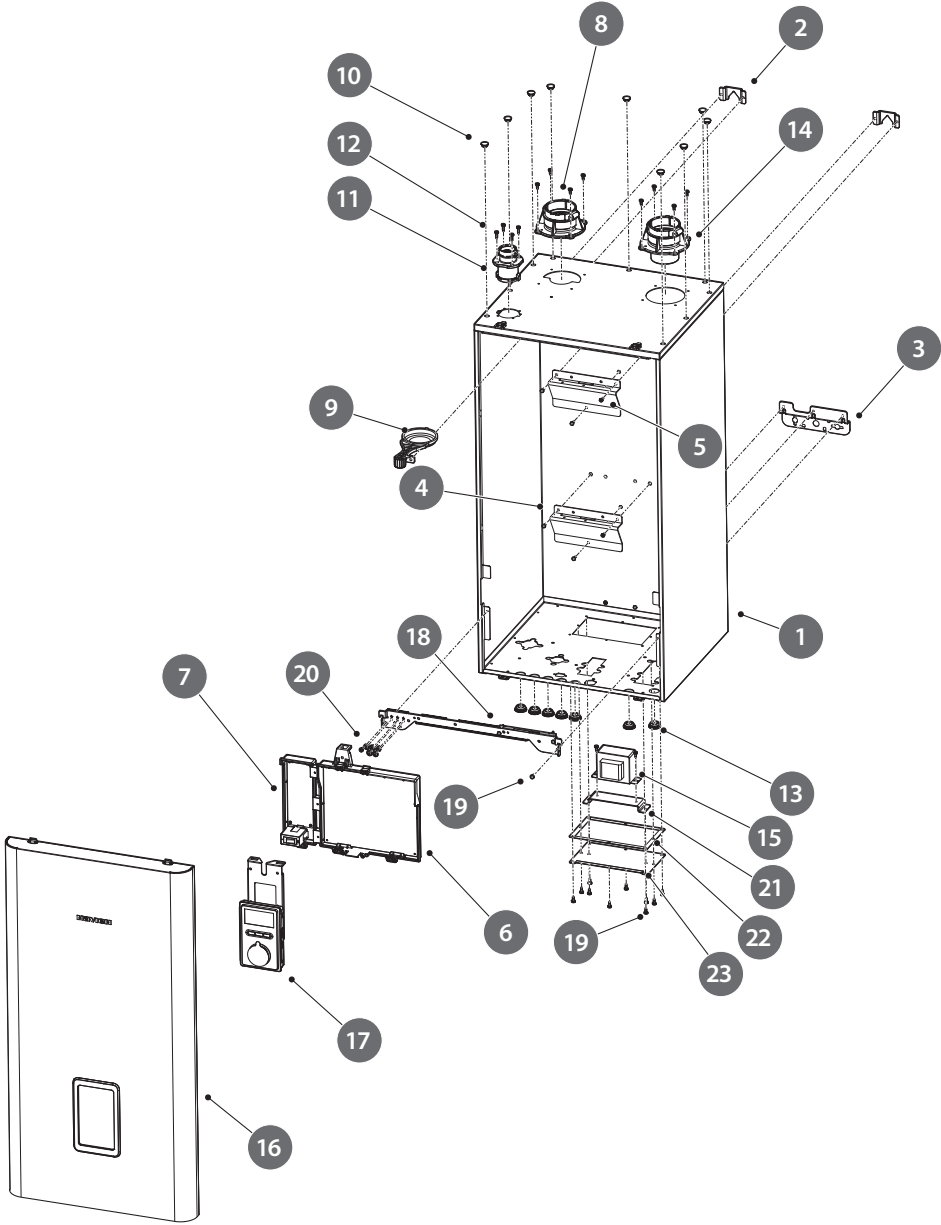

| # | Description | Part # | Remark |
|----|-------------------------------------|-----------|--------|
| 1 | Case Upper | 20041092A | |
| | Case Middle | 20044456A | |
| | Case Lower | 20044457A | |
| 2 | Base Bracket | 20007609A | |
| 3 | Base Lower Bracket | 20007643B | |
| 4 | Heat Exchanger Bracket | 20040243A | |
| 5 | Screw (M4X10L) | 20038757A | |
| 6 | Main PCB | 30021486A | |
| 7 | Terminal PCB | 30021496A | |
| 8 | Intake Air Duct Assembly | 30008662B | |
| 9 | Intake Air Filter | 30016248B | |
| 10 | Base Packing | 20041078A | |
| 11 | Air Vent Adapter | 20045716A | |
| 12 | Screw (M4X14L) | 20038754A | |
| 13 | Rubber Ring | 20029318A | |
| 14 | Exhaust Duct Assembly | 30008673A | |
| 15 | 24V Power Transformer | 30019688A | |
| 16 | Cover | 30021870A | |
| 17 | Front Panel | 30022192A | |
| 18 | PCB Lower Bracket | 30022565A | |
| 19 | Screw (M4X10L) | 20038753A | |
| 20 | Screw (M4X8L) | 20044834A | |
| 21 | 24V Power Transformer Bracket | 20042385A | |
| 22 | 24V Power Transformer Plate Packing | 20045757A | |
| 23 | 24V Power Transformer Plate | 20045758A | |

| # | Description | Part # | Remark |
|----|--------------------------------|-----------|-------------|
| 1 | Heat Exchanger Assembly | 30019155A | NFC-175/200 |
| 2 | Drain Pan Assembly | 30021887A | |
| 3 | Fastener | 20040255A | |
| 4 | Heat Exchanger Drain Cap | 20042237A | |
| 5 | Drain Pan Packing | 20040241A | |
| 6 | O-ring (P26) | 20032409A | |
| 7 | Drain Pan Adapter | 20044473A | |
| 8 | Screw (M4X10L) | 20038753A | |
| 9 | Exhaust Duct (Lower) | 20040242A | |
| 10 | Exhaust Duct (Upper) | 20040727B | |
| 11 | Exhaust Duct Packing (G90) | 20022326A | |
| 12 | Exhaust Duct Packing (P85) | 20042823A | |
| 13 | Exhaust Duct Clip | 20042741A | |
| 14 | Exhaust Duct Cap | 20029712A | |
| 15 | Thermistor (Exhaust) | 30020489A | |
| 16 | Exhaust Duct Packing (Upper) | 20024690A | |
| 17 | Screw (M4X6L) | 20006535A | |
| 18 | Screw (M4X20L) | 20042814A | |
| 19 | Air Pressure Sensor | 30015811A | |
| 20 | Heat Exchanger Inlet Adapter | 30021873A | |
| 21 | O-ring (V32) | 20041403A | |
| 22 | Water Hose (Drain Pan) | 30021859A | |
| 23 | Heat Exchanger Outlet Adapter | 30019645A | |
| 24 | Thermistor | 30012907A | |
| 25 | Packing (P27) | 20041401A | |
| 26 | Supply Pipe (Upper) | 30019177A | |
| 27 | Supply Pipe (Lower) | 30021861A | |
| 28 | LWCO (Pressure Sensor) Packing | 20006873A | |
| 29 | LWCO (Pressure Sensor) | 30021482A | |
| 30 | LWCO Adapter Cap | 20044479A | |
| 31 | High Limit Switch | 30002558A | |

12.6.3 Combustion Parts Assembly

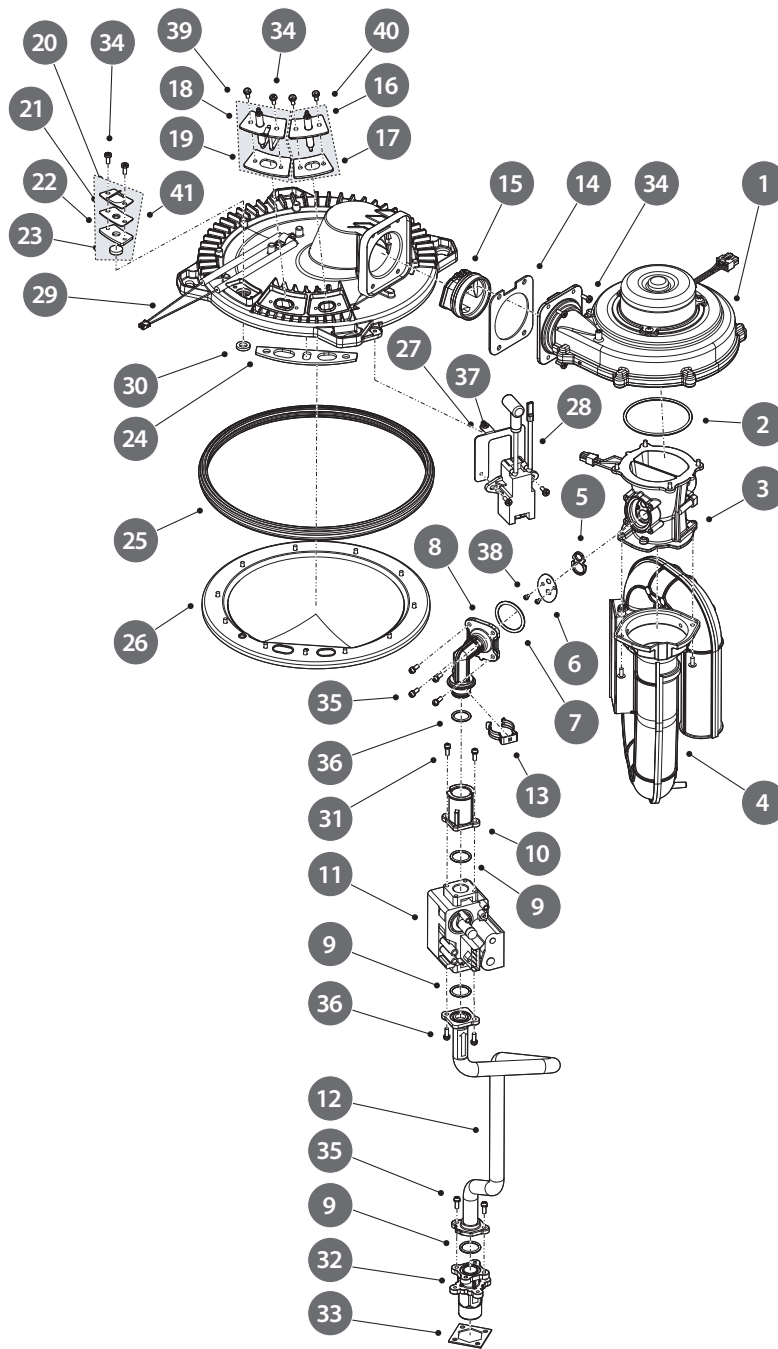

| # | Description | Part # | Remark |
|----|--|-----------|--|
| 1 | Fan Assembly | 30019106A | NFC-175/200 |
| 2 | Venturi Packing | 20018079A | |
| 3 | Dual Venturi | 30017402A | NFC-175/200 |
| 4 | Intake Pipe | 30019120A | |
| 5 | Orifice Packing | 20022660A | |
| 6 | Gas Orifice | 20041039A | NFC-175/200 (NG) |
| | | 20041040A | NFC-175/200 (LP) |
| | | 20045082A | NFC-175/200 High Altitude (NG) |
| 7 | O-Ring (P34) | 20019090A | |
| 8 | Gas Connector (Upper) | 20042238A | |
| 9 | O-Ring (P20) | 20006934A | |
| 10 | Gas Connector Adapter | 20042239A | |
| 11 | Gas Valve | 30011586B | |
| 12 | Gas Pipe | 30021872A | |
| 13 | Fastener | 20007878A | |
| 14 | Fan Packing | 20042399A | |
| 15 | Fan Damper | 30008825A | |
| 16 | Flame Rod | 30019166A | |
| 17 | Flame Rod Packing | 20045645A | |
| 18 | Igniter | 30019165A | |
| 19 | Igniter Packing | 20045644A | |
| 20 | Flame inspection window (Upper) | 20040231A | |
| 21 | Flame inspection window (Lower) | 20040232A | |
| 22 | Flame inspection window (Graphite Packing) | 20043399B | |
| 23 | Flame inspection window (Glass) | 20040236A | |
| 24 | Packing (Graphite) | 20040233B | |
| 25 | Burner Packing | 20040228A | |
| 26 | Burner | 20040226A | |
| 27 | Ignition Transformer Bracket | 20041154A | |
| 28 | Ignition Transformer | 30019980A | |
| 29 | Burner Temperature Fuse | 30020776A | |
| 30 | Packing (Graphite) | 20040234A | |
| 31 | Screw (M4X12) | 20006390A | |
| 32 | Gas Inlet Adapter | 20042244A | |
| 33 | Packing (EVA) | 20023581A | |
| 34 | Screw (M4X10) | 20038758A | |
| 35 | Screw (M4X12) | 20006390A | |
| 36 | O-ring (P18) | 20023434A | |
| 37 | Screw (M4X6) | 20038752A | |
| 38 | Screw (M3X5) | 20006365A | |
| 39 | (SET) Igniter | 30021275B | Includes Igniter and Packing |
| 40 | (SET) Flame Rod | 30021274B | Includes Flame Rod and Packing |
| 41 | (SET) Flame Inspection Window | 30021277A | Includes Upper/Lower/Glass and Packing |

12.6.4 Waterway Assembly

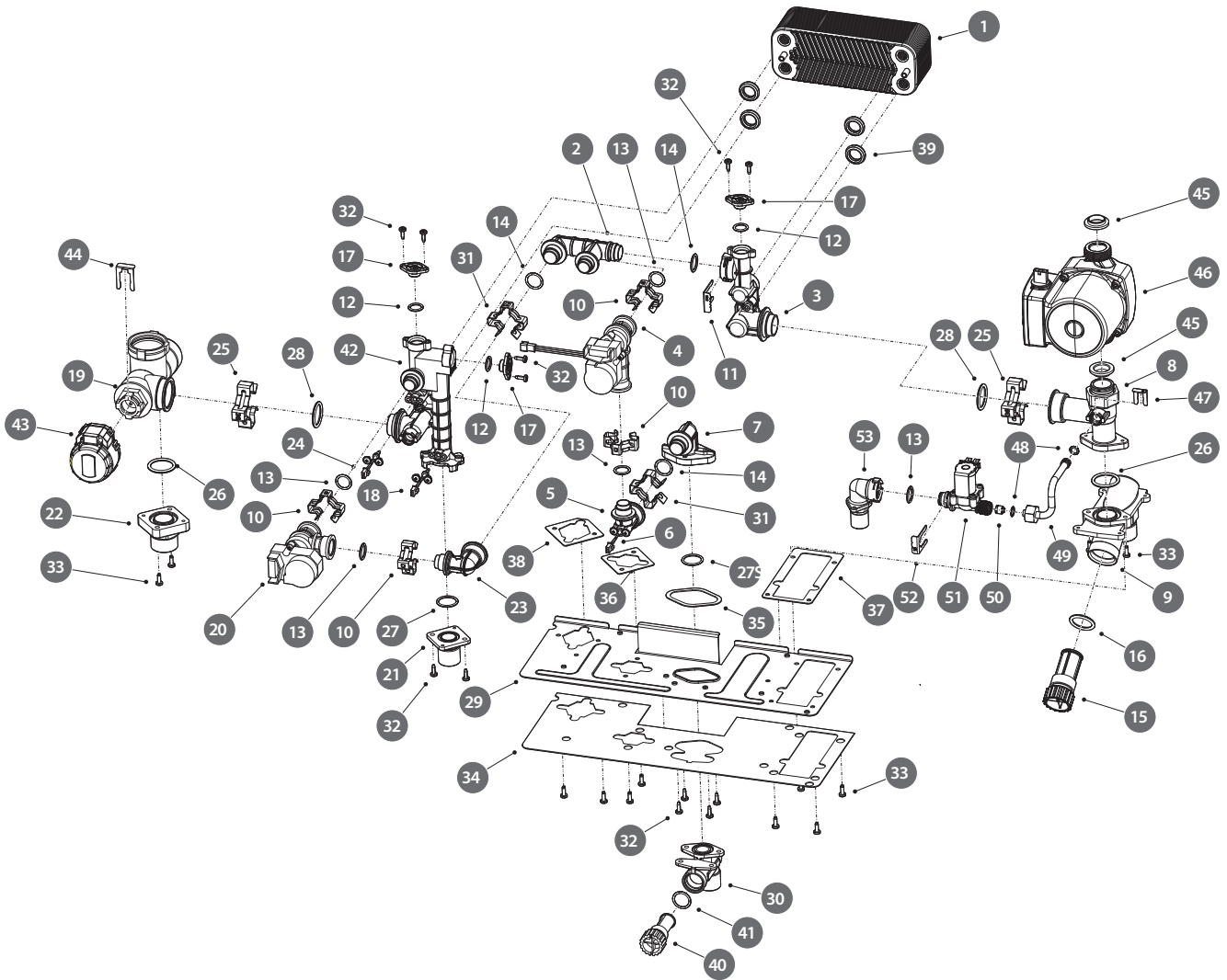

| # | Description | Part # | Remark |
|----|--------------------------------|-----------|--------|
| 1 | Plate Heat Exchanger | 30021098A | |
| 2 | DHW Connection Adapter | 30021869A | |
| 3 | Mixing Valve Adapter | 20044471A | |
| 4 | Flow Adjust Valve | 30008247A | |
| 5 | DHW Inlet Connection Adapter | 20044470A | |
| 6 | DHW Temperature Sensor (Blue) | 30022207A | |
| 7 | DHW Inlet Connection Adapter | 20044477A | |
| 8 | Circulation Pump Inlet Adapter | 30021865A | |
| 9 | Heating Return Adapter | 20044488A | |
| 10 | Fastener (D) | 20007859A | |

| # | Description | Part # | Remark |
|----|--------------------------------|-----------|--------|
| 11 | Fastener (19.7) | 20007733B | |
| 12 | O-Ring (P14) | 20011438A | |
| 13 | O-Ring (P16) | 20017210A | |
| 14 | O-Ring (P18) | 20006947A | |
| 15 | Heating Return Adapter Filter | 30014682A | |
| 16 | O-Ring (P25) | 20032528A | |
| 17 | Cap | 20017744A | |
| 18 | DHW Temperature Sensor (Red) | 30015178A | |
| 19 | 3-Way Valve Body | 30022588A | |
| 20 | Mixing Adjust Valve | 30011532A | |
| 21 | DHW Outlet Adapter | 20044487A | |
| 22 | Heating Supply Adapter | 20044489A | |
| 23 | DHW Connection Elbow | 20025962B | |
| 24 | DHW Temperature Sensor (Black) | 30022222A | |
| 25 | Fastener (36) | 20017724A | |
| 26 | O-Ring (P28) | 20022142A | |
| 27 | O-Ring (P22) | 20018011A | |
| 28 | O-Ring (P26) | 20032409A | |
| 29 | Block Plate | 20044475A | |
| 30 | DHW Inlet Adapter | 20044701A | |
| 31 | Fastener (27) | 20017726A | |
| 32 | Screw (M4×12) | 20041461A | |
| 33 | Screw (M4×10) | 20038757A | |
| 34 | Block Plate Packing | 20045394A | |
| 35 | DHW Inlet Adapter Packing | 20045393A | |
| 36 | DHW Outlet Adapter Packing | 20045395A | |
| 37 | Heating Return Adapter Packing | 20045397A | |
| 38 | Heating Supply Adapter Packing | 20045396A | |
| 39 | Plate Heat Exchanger Packing | 20035234B | |
| 40 | DHW Inlet Adapter Filter | 30008171A | |
| 41 | O-Ring (P19) | 20017211A | |
| 42 | Mixing Valve Manifold | 20044482A | |
| 43 | 3-Way Valve Motor | 30021775A | |
| 44 | 3-Way Valve Clip | 20045768A | |
| 45 | Circulation Pump Packing | 20044484A | |
| 46 | Circulation Pump | 30021636A | |
| 47 | Fastener (8) | 20034617A | |
| 48 | O-Ring (P8) | 20006963A | |
| 49 | Water Supplement Pipe | 30021875A | |
| 50 | Check Valve | 30015223A | |
| 51 | Water Valve | 30016037A | |
| 52 | Fastener (16) | 20007736B | |
| 53 | Water Supply Adapter | 20044486A | |

Memo

Memo

Installation & Operation Manual

NFC Condensing Combi-Boilers

Getting Service

If your boiler requires service, you have several options for getting service:

- Contact Technical Support at 1-800-519-8794 or on the website: www.navien.com.
- For warranty service, always contact Technical Support first.
- Contact the technician or professional who installed your boiler.
- Contact a licensed professional for the affected system (for example, a plumber or electrician).

When you contact Technical Support, please have the following information at hand:

- Model number
- Serial number
- Date purchased
- Installation location and type
- Error code, if any appears on the front panel display.

Version: 1.0 (Jan 25, 2019)



800.519.8794 | www.Navien.com
20 Goodyear Irvine, CA 92618