

Receptacle Repair Kit

MODEL: CI-390

REPAIR KIT CONTENTS:

- (One) Replacement Plug & Cord (consisting of a six inch length of wire with a plug on one end and an AMP connector half on the other)
- (One) AMP Connector Half & Cover
- (Two) Screws
- Instructions

TOOLS REQUIRED:

- Screwdrivers (Phillips: Medium & Small)
- Electrician's Sidecutters
- Keyhole Saw
- Knife or Wire Strippers
- Pliers ("Channel Lock" Type)
- Voltage Tester

WARNING

Before proceeding with this repair, **ENSURE POWER TO EACH CI-390 INLET IS TURNED OFF!** NOTE: To ensure that the power is off, test with a voltage tester.

1. Open inlet door and remove the two inlet retaining screws. Pull inlet out of the mounting plate as far as the cord will allow. Using sidecutters, cut the cord as close to the back of the plug as possible. Put inlet to one side.
2. Using the drawing as a guide, cut the shaded area away using sidecutters (Fig. 1). Cut the side wall of plastic away between the two shaded slots (Fig. 1), using the keyhole saw inserted at an angle as shown (Fig. 2). Hint: When cutting the mounting plate, only saw 90% of the first cut, then proceed to the second cut. Leaving a bridge of plastic on the first cut will maintain support, making the second cut much easier.
3. Using a knife or wire strippers, strip the outer sleeve on the remaining wire protruding from the wall and install the "AMP" connector, as described in the instructions supplied with the unit.

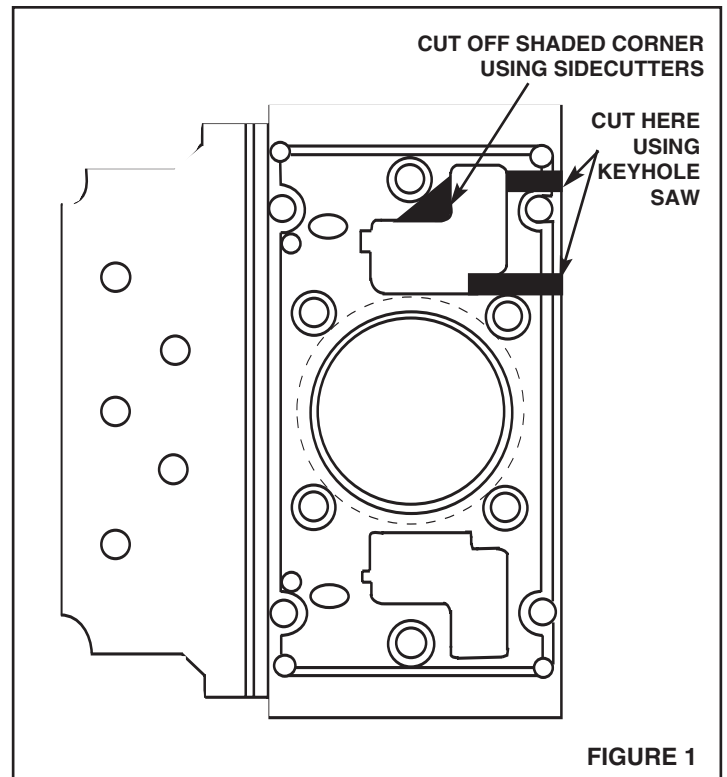

FIGURE 1

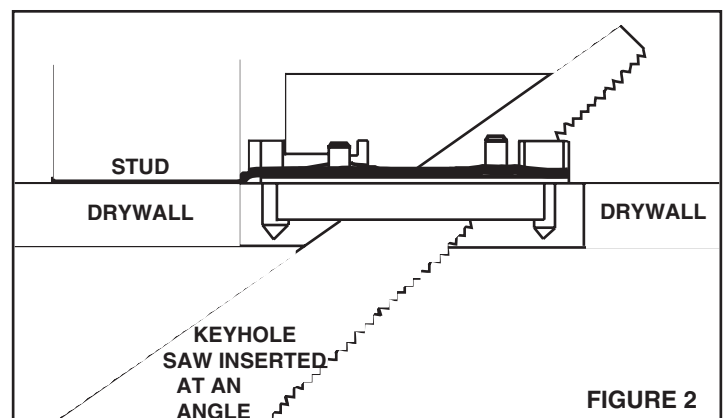

FIGURE 2

4. Snap both halves of the AMP connector together and push it through the enlarged hole in the mounting plate, while pushing the inlet spigot into the seal.
5. Carefully remove the old plug from the inlet with the use of pliers, by tipping the rear of the plug in towards the inlet spigot and lifting it out of the retaining clips on each side.
6. Snap in the replacement plug by inserting it into the two retaining clips on the rear of the inlet, sliding it down until it snaps into the square hole in the inlet face. NOTE: The plug is designed to be installed with the narrow opening upwards and with the 125V 7 AMP ungraving on the front in a vertical position (Fig. 3). When snapping the plug into the inlet wings, moisten or lubricate slightly for easy insertion. Secure the inlet using the original screws in the same position. DO NOT OVERTIGHTEN.

At this point, turn the power back on and verify with a voltage tester.

The installation is now complete.

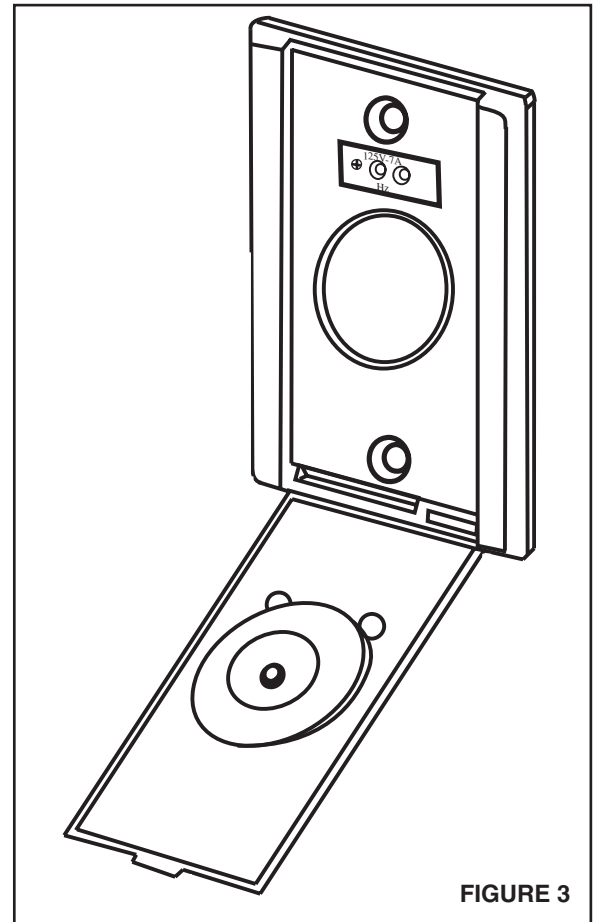

FIGURE 3

Product specifications subject to change without notice.

NuTone®

4820 Red Bank Road, Cincinnati, Ohio 45227
1140 Tristar Drive, Mississauga, Ontario, Canada L5T 1H9
www.nutone.com
Printed in U.S.A., Rev. 3/02, Part No. 0678B