

200 PSI Butterfly Valves

Ductile Iron Body • Extended Neck • Geometric Drive
Molded-in Seat Liner • Lug and Wafer Style

Sizes 2" through 12"

Install between Std. ASME Class 125/150 Flanges. Lug Style 200 PSI bi-directional dead end service rating without a downstream flange required.

DESIGNED TO MEET MSS SP-67 STANDARD •
U.S. COAST GUARD "CATEGORY A" • CERTIFIED LEAD-FREE* BY
TRUESDAIL LABS TO NSF/ANSI 61-8 COMMERCIAL HOT 180°F
(INCLUDES ANNEX F AND G) AND NSF/ANSI-372



NSF/ANSI 61
NSF/ANSI 372



WD 2000

Wafer Style
EPDM Liner
and Aluminum
Bronze Disc

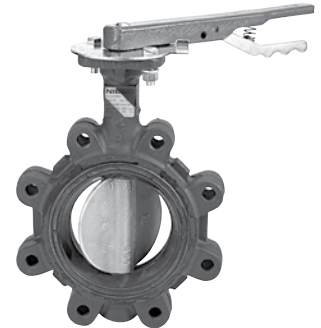

LD 2000

Lug Style
EPDM Liner
and Aluminum
Bronze Disc

MATERIAL LIST	
PART	SPECIFICATION
1. Stem	Stainless Steel ASTM A582 Type 416
2. Collar Bushing	Brass ASTM B16
3. Stem Seal	EPDM Rubber
4. Body Seal	EPDM Rubber
5. Nameplate	Aluminum
6. Upper Bushing	Copper CDA 122
7. Liner	EPDM Rubber
8. Disc	Alum. Brz. ASTM B148 Alloy 955
9. Lower Bushing	Copper CDA 122
10. Body Wafer	Ductile Iron ASTM A536
11. Body Lug	Ductile Iron ASTM A536

DIMENSIONS — WEIGHTS

Size	A						G	Metal	Rubber	J	N	
In. mm.	A	B	C	D	E	F	Flat	H	I	Square	Dia.	
2	50	2.53	4.00	1.25	5.38	2.88	.38	.312	1.688	1.812	3.25	.500
2½	65	2.90	4.69	1.25	5.88	3.27	.38	.370	1.812	1.938	3.25	.562
3	80	3.15	5.12	1.25	6.12	3.40	.38	.370	1.812	1.938	3.25	.562
4	100	4.09	6.12	1.25	6.88	4.00	.38	.403	2.062	2.188	3.25	.625
5	125	5.13	7.25	1.25	7.38	4.75	.38	.496	2.188	2.312	3.25	.750
6	150	6.13	8.25	1.25	8.00	5.29	.38	.496	2.188	2.312	3.25	.750
8	200	8.13	10.41	1.25	9.25	6.50	.50	.560	2.375	2.500	3.25	.875
10	250	10.13	12.52	1.25	10.50	8.00	.50	.686	2.688	2.812	4.75	1.125
12	300	12.13	15.00	1.25	12.00	9.25	.50	.748	3.000	3.125	4.75	1.250

Capscrew/Stud Data

Size	O	P	R	K	L	Wafer	Lug	M	Lug Weight		Wafer Weight	
In. mm.	B.C.	Dia.	Dia.	No.	Dia.	Length	Length	B.C.	Lbs.	Kg.	Lbs.	Kg.
2	50	3.25	.437	.437	4	5/8-11unc	Refer to butterfly valve technical information for bolt lengths	4¾	7	3.2	5.5	2.5
2½	65	3.25	.437	.500	4	5/8-11unc		5½	9	4.1	7.5	3.4
3	80	3.25	.437	.500	4	5/8-11unc		6	9.5	4.3	8	3.6
4	100	3.25	.437	.562	8	5/8-11unc		7½	15	6.8	11	5.0
5	125	3.25	.437	.656	8	¾-10unc		8½	21	9.5	15	6.8
6	150	3.25	.437	.656	8	¾-10unc		9½	24	10.9	18	8.2
8	200	3.25	.437	.781	8	¾-10unc		11¾	34	15.4	28	12.7
10	250	5.00	.562	1.000	12	7/8-9unc		14¼	62	28.1	45.5	20.7
12	300	5.00	.562	1.062	12	7/8-9unc		17	90	40.9	70	31.8

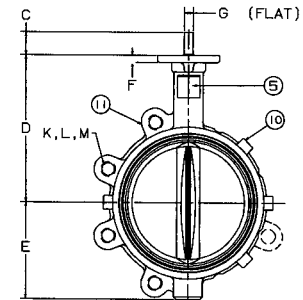
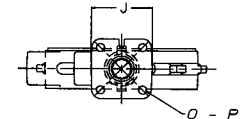
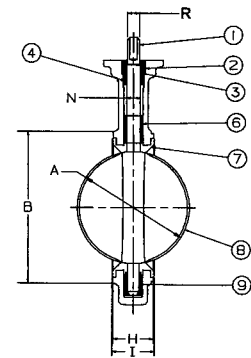

NOT RECOMMENDED
FOR STEAM SERVICE

For actuated service where a lower torque is required use NIBCO Fig. No. WDLXXX-0 or LDLXXX-0 series, sizes 2" thru 12" only. Maximum pressure rating of 100 PSI for wet application and 50 PSI for dry application.

*Weighted average lead content ≤ 0.25%

200 PSI Butterfly Valves

Ductile Iron Body • Extended Neck • Geometric Drive
Molded-in Seat Liner • Lug and Wafer Style

Sizes 2" through 12"

Install between Std. ASME Class 125/150 Flanges
Lug Style 200 PSI bi-directional dead end service rating without a downstream flange required.

DESIGNED TO MEET MSS SP-67 STANDARD
U.S. COAST GUARD "CATEGORY A"



WD 2100
Wafer Style
Buna-N Liner
and Aluminum
Bronze Disc

LD 2100
Lug Style
Buna-N Liner
and Aluminum
Bronze Disc

MATERIAL LIST

PART	SPECIFICATION
1. Stem	Stainless Steel ASTM A582 Type 416
2. Collar Bushing	Brass ASTM B16
3. Stem Seal	Buna-N Rubber Nitrile
4. Body Seal	Buna-N Rubber Nitrile
5. Nameplate	Aluminum
6. Upper Bushing	Copper CDA 122
7. Liner	Buna-N Rubber Nitrile
8. Disc	Alum. Brz. ASTM B148 Alloy 954/955
9. Lower Bushing	Copper CDA 122
10. Body Wafer	Ductile Iron ASTM A536
11. Body Lug	Ductile Iron ASTM A536

DIMENSIONS — WEIGHTS

Size	G							Metal	Rubber	J	N
In. mm.	A	B	C	D	E	F	Flat	H	I	Square	Dia.
2 50	2.53	4.00	1.25	5.38	2.88	.38	.312	1.688	1.812	3.25	.500
2½ 65	2.90	4.69	1.25	5.88	3.27	.38	.370	1.812	1.938	3.25	.562
3 80	3.15	5.12	1.25	6.12	3.40	.38	.370	1.812	1.938	3.25	.562
4 100	4.09	6.12	1.25	6.88	4.00	.38	.403	2.062	2.188	3.25	.625
5 125	5.13	7.25	1.25	7.38	4.75	.38	.496	2.188	2.312	3.25	.750
6 150	6.13	8.25	1.25	8.00	5.29	.38	.496	2.188	2.312	3.25	.750
8 200	8.13	10.41	1.25	9.25	6.50	.50	.560	2.375	2.500	3.25	.875
10 250	10.13	12.52	1.25	10.50	8.00	.50	.686	2.688	2.812	4.75	1.125
12 300	12.13	15.00	1.25	12.00	9.25	.50	.748	3.000	3.125	4.75	1.250

Capscrew/Stud Data

Size	O	P	R	K	L	Wafer	Lug	M	Lug Weight		Wafer Weight	
In. mm.	B.C.	Dia.	Dia.	No.	Dia.	Length	Length	B.C.	Lbs.	Kg.	Lbs.	Kg.
2 50	3.25	.437	.437	4	¾-11unc			4¾	7	3.2	5.5	2.5
2½ 65	3.25	.437	.500	4	¾-11unc			5½	9	4.1	7.5	3.4
3 80	3.25	.437	.500	4	¾-11unc			6	9.5	4.3	8	3.6
4 100	3.25	.437	.562	8	¾-11unc			7½	15	6.8	11	5.0
5 125	3.25	.437	.656	8	¾-10unc			8½	21	9.5	15	6.8
6 150	3.25	.437	.656	8	¾-10unc			9½	24	10.9	18	8.2
8 200	3.25	.437	.781	8	¾-10unc			11¾	34	15.4	28	12.7
10 250	5.00	.562	1.000	12	7/8-9unc			14¼	62	28.1	45.5	20.7
12 300	5.00	.562	1.062	12	7/8-9unc			17	90	40.9	70	31.8

Refer to butterfly valve technical information for bolt lengths

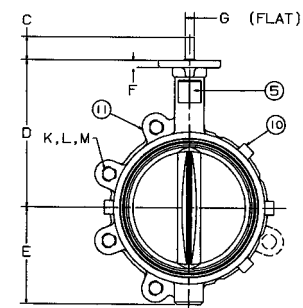
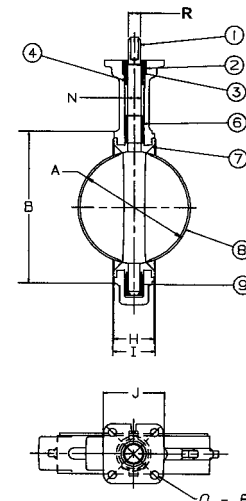

NOT RECOMMENDED FOR STEAM SERVICE

For actuated service where a lower torque is required use NIBCO Fig. No. WDLXXX-0 or LDLXXX-0 series, sizes 2" thru 12" only. Maximum pressure rating of 100 PSI for wet application and 50 PSI for dry application