

Location: _____



MI-G-PL

**Lil Max – 7 to 50 GPM
HDPE Grease Interceptors**



Specification: MIFAB Series MI-G-PL ____ HDPE injection molded hydro mechanical grease interceptor with flow rating of ____ (indicate) and grease holding capacity of ____ (indicate). Unit shall include: removable baffle assembly, deep seal trap covered by lid, sewer gas stopper, securing latches, external vented flow control fitting, internal air relief by pass, HDPE injection molded, non skid, rectangular gasketed lid(s). Interceptor shall be tested and certified to the P.D.I. Standard PDI-G101, CSA B481, A.S.M.E. A112.14.3 and listed with I.A.P.M.O.

Function: Used in restaurants, kitchens, institutions and other types of food processing areas where fat, oil and grease (FOG) drains with the wastewater. External flow control fitting must be installed according to manufacturer’s instructions to control rate of flow into the interceptor and therefore, the operating efficiency. Interceptor may be installed on the ground, semi recessed or flush with the floor. Simple latch lid design permits fast and easy removal of the lid for cleaning and maintenance. HDPE injection molded body and lid is covered by a limited lifetime warranty. Sewer gas stopper prevents foul odors from entering the kitchen area through the interceptor.

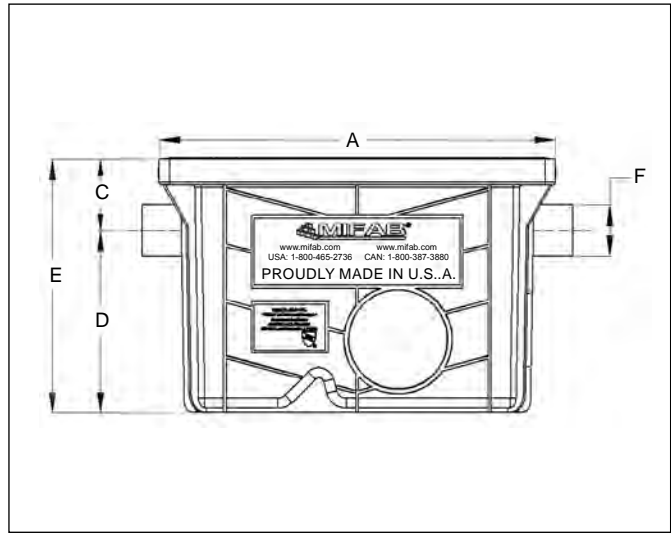
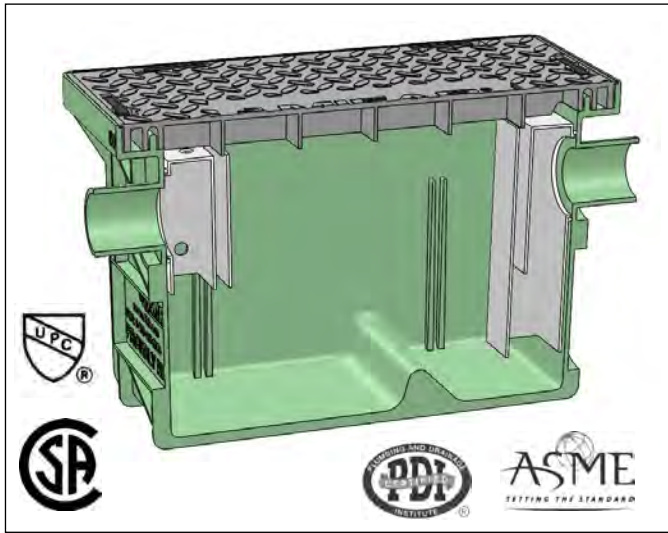

MODEL NO.	FLOW RATE (GPM)	GREASE CAP. (LBS.)	LIQUID CAP. (LBS.)	A (IN)	B (IN) WIDTH	C (IN)	D (IN)	E (IN)	F (IN)
MI-G-1-PL	7	14	5.8	19.5	15.5	3.5	9	12.5	2
MI-G-2-PL	10	20	8.5	23	17.5	3.5	9.75	13.25	2
MI-G-3-PL	15	30	13	23	17.5	3.5	13.25	16.75	2
MI-G-4-PL	20	40	16	29.5	20.5	3.5	10.75	14.25	3
MI-G-5-PL	25	50	23	29.5	20.5	3.5	14.75	18.25	3
MI-G-6-PL	35	70	39	33	25.5	5.5	16.75	22.25	3
MI-G-7-PL	50	100	44	33	25.5	5.5	18.75	24.25	3
MI-G-L-25-PL	25	50	19	33	25.5	3.5	9	12.5	3

SUFFIX OPTIONAL VARIATIONS:

- C Extension “C” as required (fabricated powder epoxy coated steel)
- DP Dosing pump

SUFFIX OPTIONAL VARIATIONS:

- EP Enzyme port
- HLA High level alarm
- SB Sediment bucket