

# 105F Flanged Cast Iron Gate Valve • Spec Sheet

Sizes 2" - 12"

## FEATURES & BENEFITS

- ISO-9002
- Gate Valve - Flanges Ends
- 200 WOG-125 SWP
- Iron Body, Bronze Mounted (IBBM)
- 3 Bossing for Tapping
- Bolted Bonnet
- Outside Stem & Yoke, Rising Stem
- Solid Wedge
- Conforms to MSS-SP70
- Flanged Ends Conforms w/ ANSI B16.1
- Bituminous Coating
- Sizes 2" - 24"

## APPLICATIONS:

Low Pressure  
Steam, Water, Air,  
& Non-Corrosive  
Gas or Oil

## DIMENSIONS

Size	L	ØD	ØC	Øh	n	T	ØS	H1	H2	H3	ØW	Approx. Weight
2"	7	6	4-3/4	3/4	4	5/8	3/4	11-9/16	13-11/16	3	6-5/16	28.6
2-1/2"	7-1/2	7	5-1/2	3/4	4	11/16	3/4	12-1/2	15-5/16	3-1/2	7-1/8	37.4
3"	8	7-1/2	6	3/4	4	3/4	3/4	14-1/2	17-7/8	3-3/4	7-13/16	49.5
4"	9	9	7-1/2	3/4	8	15/16	7/8	17-3/4	21-7/8	4-1/2	9-7/8	85.8
5"	10	10	8-1/2	7/8	8	15/16	1	20-1/8	25-5/16	5	11	113.3
6"	10-1/2	11	9-1/2	7/8	8	1	1	24-3/16	30-3/8	5-1/2	11-13/16	149.6
8"	11-1/2	13-1/2	11-3/4	7/8	8	1-1/8	1-1/8	30-1/16	38-5/16	6-3/4	14	248.6
10"	13	16	14-1/4	1	12	1-3/16	1-1/4	36-3/16	46-7/16	8	15-9/16	374.0
12"	14	19	17	1	12	1-1/4	1-1/2	41-3/4	54-1/16	9-1/2	17-3/4	523.6

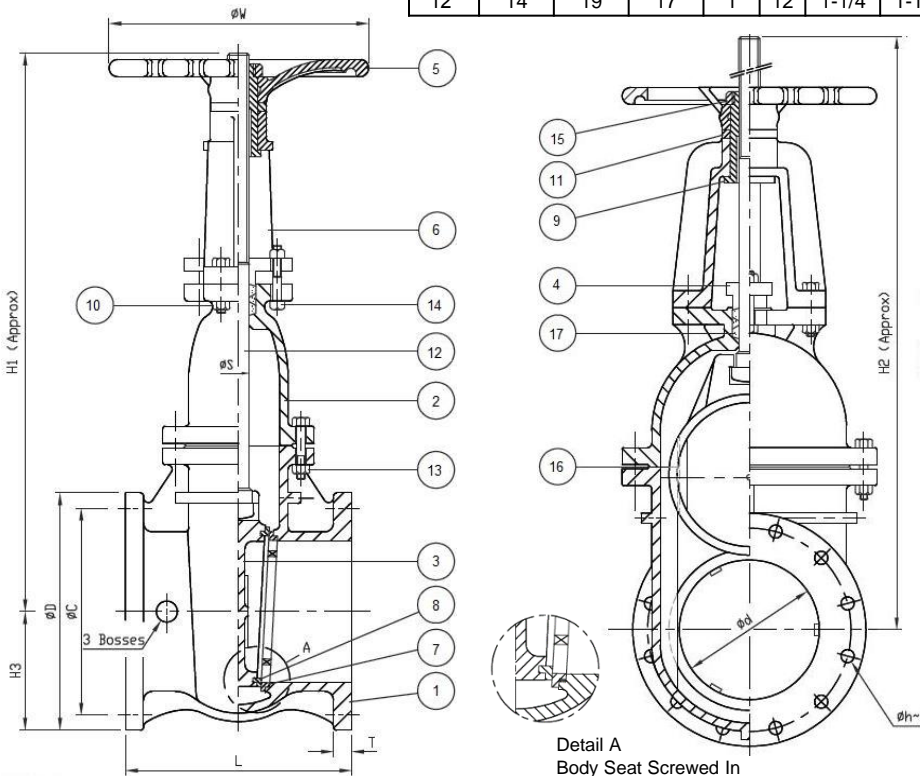

## MATERIAL SPECIFICATIONS

No.	Part	Material
1	Body	Cast Iron A 126 Class B
2	Bonnet	Cast Iron A 126 Class B
3	Disc	Cast Iron A 126 Class B
4	Gland	Cast Iron A 126 Class B
5	Hand Wheel	Cast Iron A 126 Class B
6	Yoke	Cast Iron A 126 Class B
7	Body Seat Ring	Bronze B 62
8	Disc Seat Ring	Bronze B 62
9	Yoke Sleeve	Brass B 584
10	Yoke Bolt & Nut	Zinc Coated Steel A 307 Grade B
11	Hand Wheel Washer	Brass B21
12	Stem	Bronze B 21
13	Bonnet Bolt & Nut	Zinc Coated Steel A 307 Grade B
14	Gland Bolt & Nut	Zinc Coated Steel A 307 Grade B
15	Hand Wheel Nut	Zinc Coated Steel A 307 Grade B
16	Bonnet Gasket	Non Asbestos Sheet
17	Packing	Non Asbestos 2214

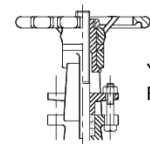

Yoke Construction  
For Sizes 2" - 3"

**MATCO-NORCA**  
Global sourcing. National compliance. Local service.

**CALIFORNIA** 5593 Fresca Dr., La Palma CA 90623 • Toll Free: 866-532-8306 • Fax: 866-532-8307  
**TEXAS** 1150 Silber Rd., Houston TX 77055 • Toll Free: 800-935-5456 • Fax: 713-680-2999  
**NEW YORK** PO Box 27, Rt. 22, Brewster NY 10509 • Toll Free: 800-431-2082 • Fax: 845-278-9056  
 WEB: [www.matco-norca.com](http://www.matco-norca.com) EMAIL: [mail@matco-norca.com](mailto:mail@matco-norca.com)

# 105F Flanged Cast Iron Gate Valve • Spec Sheet

Sizes 14" - 24"

## FEATURES & BENEFITS

- ISO-9002
- Gate Valve - Flanges Ends
- 200 WOG-125 SWP
- Iron Body, Bronze Mounted (IBBM)
- 3 Bossing for Tapping
- Bolted Bonnet
- Outside Stem & Yoke, Rising Stem
- Solid Wedge
- Conforms to MSS-SP70
- Flanged Ends Conforms w/ ANSI B16.1
- Bituminous Coating
- Sizes 2" - 24"

## APPLICATIONS:

Low Pressure  
Steam, Water, Air,  
& Non-Corrosive  
Gas or Oil

## DIMENSIONS

Size	L	ØD	ØC	Øh	N	T	ØS	A	H	H1	H2	H3	ØW	Approx. Weight
14"	15	21	18-3/4	1-1/8	12	1-3/8	1-23/32	22-3/4	37-1/4	14-9/16	12-11/16	10-9/16	15-3/4	754.60
16"	16	23-1/2	21-1/4	1-1/8	16	1-7/16	1-7/8	26	42-5/16	16-5/8	14-3/8	11-13/16	17-11/16	1012.0
18"	17	25	22-3/4	1-1/4	16	1-9/16	1-7/8	29-5/16	45-5/8	18-11/16	15-5/8	13-1/16	19-11/16	1298.00
20"	18	27-1/2	25	1-1/4	20	1-11/16	1-31/32	32-1/2	50-1/4	20-13/16	17-9/16	14-7/16	24-1/2	1848.00
24"	20	32	29-1/2	1-3/8	20	1-7/8	1-31/32	36-9/16	58-5/8	22-1/16	24-3/4	16-15/16	24-1/2	2645.50

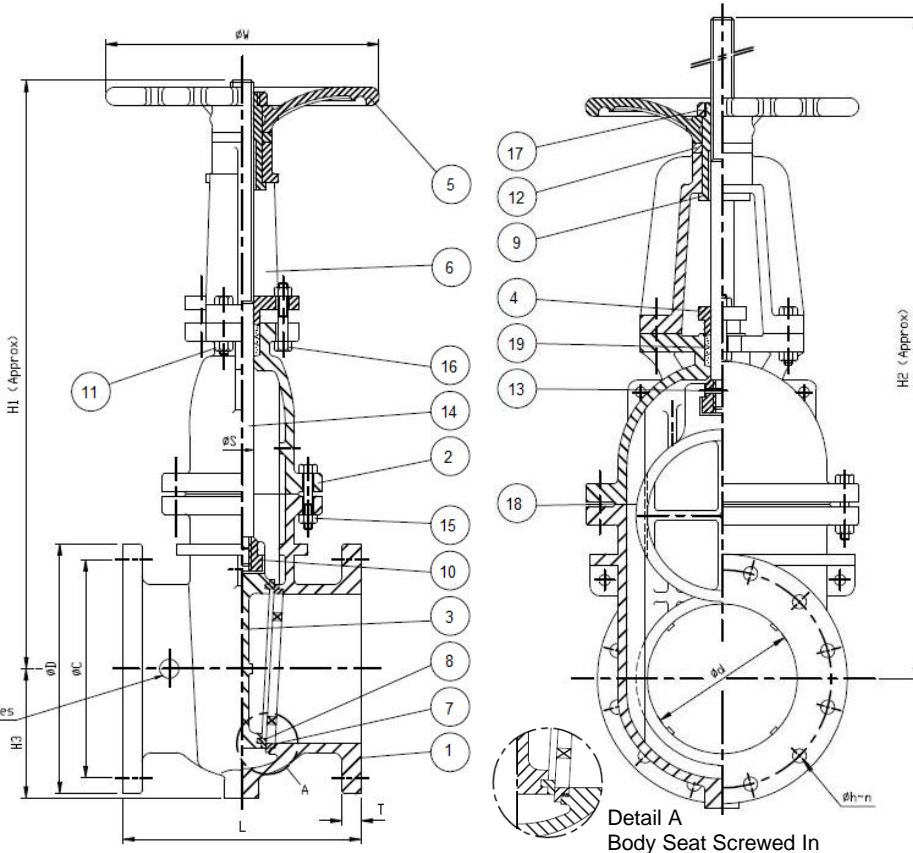

## MATERIAL SPECIFICATIONS

No.	Part	Material
1	Body	Cast Iron A 126 Class B
2	Bonnet	Cast Iron A 126 Class B
3	Disc	Cast Iron A 126 Class B
4	Gland	Cast Iron A 126 Class B
5	Hand Wheel	Cast Iron A 126 Class B
6	Yoke	Cast Iron A 126 Class B
7	Body Seat Ring	Bronze B 62
8	Disc Seat Ring	Bronze B 62
9	Yoke Sleeve	Brass B 584
10	Stem Nut	Bronze B 62
11	Yoke Bolt & Nut	Zinc Coated Steel A 307 Grade B
12	Hand Wheel Washer	Brass B 21
13	Pin	Stainless Steel A 276 Type 304
14	Stem	Bronze B 21
15	Bonnet Bolt & Nut	Zinc Coated Steel A 307 Grade B
16	Gland Bolt & Nut	Zinc Coated Steel A 307 Grade B
17	Hand Wheel Nut	Zinc Coated Steel A 307 Grade B
18	Bonnet Gasket	Non Asbestos Sheet
19	Packing	Non Asbestos 2214

**MATCO-NORCA**  
Global sourcing. National compliance. Local service.

**CALIFORNIA** 5593 Fresca Dr., La Palma CA 90623 • Toll Free: 866-532-8306 • Fax: 866-532-8307  
**TEXAS** 1150 Silber Rd., Houston TX 77055 • Toll Free: 800-935-5456 • Fax: 713-680-2999  
**NEW YORK** PO Box 27, Rt. 22, Brewster NY 10509 • Toll Free: 800-431-2082 • Fax: 845-278-9056  
 WEB: [www.matco-norca.com](http://www.matco-norca.com) EMAIL: [mail@matco-norca.com](mailto:mail@matco-norca.com)