

Liberty Pumps®

Model ALM-2R



Wireless Alarm System *with indoor alarm box*

No more cables
No electrician required
No more digging trenches
**No damage to expensive
landscape**

Save time and money
**Features a remote
wireless transmitter
with up to 150' range!**

Features:

- Automatic alarm reset
- 9 volt DC back-up
- Alarm test switch
- Green power indicator
- Red alarm indicator
- Low battery chirp warning
- Loss of signal alarm

Transmitter Features:

- Remote wireless transmitter with up to 150' range
- Lithium battery lasts two years
- Tested to comply with FCC standards

Easy to install alarm features a battery operated wireless transmitter that is placed in the tank (up to 150 feet from the alarm). An electrician is not required since no hard-wiring is needed. When the high water alarm float switch is activated, the transmitter sends a signal, sounding the indoor alarm. No cable to bury, no damage to expensive landscape and no heavy equipment to haul.

innovate. evolve.

ALM-2R

Wireless Alarm System

Easy to install wireless liquid level alarm system with auto reset and battery back-up features.

The ALM-2R alarm system features a battery operated wireless transmitter that is placed in a tank (up to 150 feet away from the indoor alarm). When the high water alarm float switch activates, the transmitter sends a signal and sounds the indoor alarm warning of a potentially threatening liquid level condition. The horn can be silenced, but the alarm light remains on until the condition is remedied. Once the condition is cleared, the alarm will automatically reset.

The ALM-2R alarm system monitors liquid levels in lift pump chambers, sump pump basins, holding tanks, sewage, agricultural, and effluent filters, and other water applications.

Alarm Features:

- NEMA 1 enclosure rated for indoor use
- Automatic alarm reset
- Red “alarm” light and green “power on” light, alarm “test” switch, and horn “silence” switch
- 6 foot (1.8 meter) power cord.
- Alarm horn sounds at 87 decibels at 10 feet (3 meters).
- If primary power fails, the alarm system continues to work due to battery back-up feature. Battery Back-up Power: 9 VDC. (battery not included)
- Package includes non-mercury signal master switch and 10 feet (3.04 meters) of cable with transmitter.
- Switching mechanism operates on low voltage and is isolated from the power line to reduce the possibility of shock.

- Low battery chirp
- Loss of signal alarm. After 3 hours and 15 minutes without a signal, an alarm sounds and the red light blinks.
- External terminal block for an optional local alarm float.
- Two-year limited warranty.

Transmitter Features:

- Wireless transmitter with up to 150 foot range.
- Meets all FCC requirements.
- Long life lithium battery (recommended replacement 2 years).
- Transmitter transmits once per hour or when float position is changed.

Specifications:

Voltage for 120 VAC Model: Primary: 120 VAC, 60 Hz, 2.4 watts max. (alarm condition)

Battery Back-up Power: 9 VDC

Alarm Enclosure: 6 x 4 x 2.25 inch (15.24 x 10.16 x 5.71 cm), NEMA 1 plastic.

Alarm Horn: 87 decibels at 10 feet (3 meters)

Power Cord: 6 foot (1.8 meter)

Optional Float Switch Connection Terminal:

For float switch connection only. Do not apply power (voltage across terminals is 8-9 VDC).

FCC ID# SCP TAABW01

This device complies with Part 15 of the FCC Rules. Operation is subject to the following two conditions:

- This device may not cause harmful interference
- This device must accept any interference received, including interference that may cause undesired operation.

Standard Transmitter Riser

Installation (shown with mounting bracket)

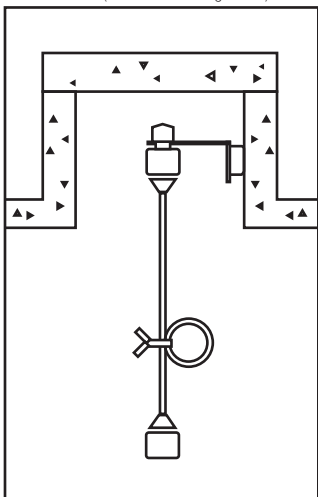

Transmitter PVC Pipe Installation

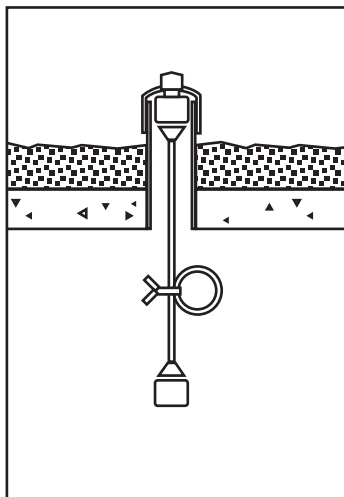

Line-Of-Sight Illustration for Alarm Mounting

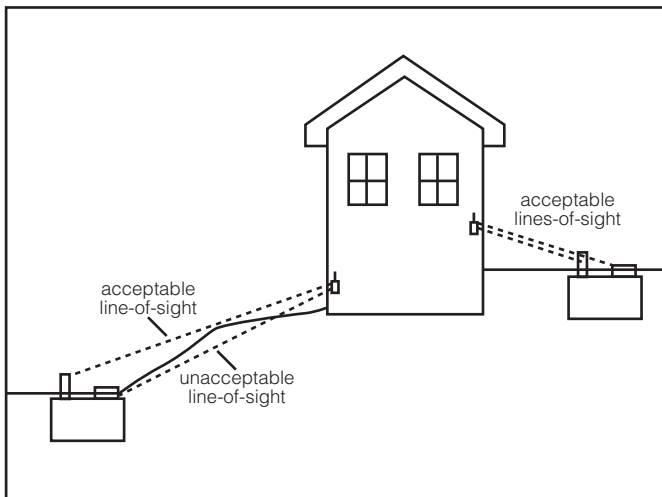

Specifications are subject to change without notice.