

120VAC Wire In with 9V Battery Back Up Heat Alarm

Model HD135F

Flashing Red LED

Flashes every 30-40 seconds to indicate proper operation

Test Button

Tests unit's electronic circuitry, horn and battery function

9V Battery Back Up

Provides continuous protection even during power outages



Description

The Kidde HD135F is a 120VAC Wire In Heat Alarm that responds to temperature rather than smoke. The alarm will sound if temperatures rise above 135°F. The Kidde HD135F is interconnectable. The interconnect system must not exceed the NFPA (National Fire Protection Association) limit of 18 initiating devices (Smoke, heat, CO, etc) interconnected, it is still possible to interconnect 6 strobe lights and or relay modules. This unit includes a 5-year limited warranty and is UL Listed.

Benefits

The Kidde HD135F 120VAC wire in heat alarm gives you and your family an early warning to dangerous temperatures of 135°F or more. This unit can be used as a single station unit or it can be interconnected to up to 24 Kidde devices in a multiple station arrangement. The interconnect system must not exceed the NFPA (National Fire Protection Association) limit of 18 initiating devices (Smoke, heat, CO, etc) interconnected, it is still possible to interconnect 6 strobe lights and or relay modules. The HD135F includes a tamper resist pin to help deter tampering or theft.

Features and Benefits

- **Interconnectable** – Interconnects with up to 24 Kidde devices of which 18 can be initiating.
- **Test Button** – Tests unit's electronic circuitry, horn and battery function.
- **9V Battery Back Up** – Provides continuous protection even during power outages.
- **Red LED** – Flashes every 30-40 seconds to indicate proper operation.
- **Low Battery Indicator** – Alerts user in the event of a low or missing battery.
- **Quick Connect Power Harness** – Makes installation fast and easy.



Architectural and Engineering Specifications

The heat alarm shall be Kidde Unit HD135F or approved equal. It shall be powered by a 120VAC, 60Hz source along with a 9V battery backup. The temperature operation range shall be between -20F to +100F (-29C and +38C) and the humidity operation range shall be 5% - 95% relative humidity.

The heat alarm can be installed on any standard single gang electrical box, up to a 4" octagon junction box. The electrical connection (to the alarm) shall be made with a plug-in connector. A maximum of 24 Kidde devices can be interconnected in a multiple station arrangement. The interconnect system must not exceed the NFPA (National Fire Protection Association) limit of 18 initiating devices (Smoke, heat, CO, etc) interconnected, it is still possible to interconnect 6 strobe lights and or relay modules. The alarm shall provide optional tamper resistance that deters removal of the unit from the wall or ceiling.

The unit shall include a piezoelectric horn that is rated at 85dB at 10ft. The unit shall incorporate 2 LED's. A green LED will be constantly "ON" when AC power is present. A red LED will flash once approximately every 30-40 seconds to indicate that the smoke alarm is operating properly and will flash rapidly when the unit is alarming and will remain so until the air temperature is reduced.

The unit shall incorporate a test button. The test button shall test all the electronic circuitry, horn, and battery.

The unit shall at a minimum meet the requirements of UL217, NFPA72, (chapter 10 & 11 2002 edition) The State of California Fire Marshall, NFPA101 (One and two family dwellings, Federal Housing Authority (FHA), Housing and Urban Development (HUD).

HEAT ALARMS ARE NOT DESIGNED TO PROTECT LIFE SAFETY AGAINST FIRE AND SMOKE. IN CASES WHERE LIFE SAFETY IS AN ISSUE, HEAT ALARMS SHOULD ONLY BE USED AS A SUPPLEMENT TO THE SMOKE ALARM INSTALLATION

Technical Specifications

Model Number:	HD135F
UPC:	0-25417-84135-0
Power Source:	120VAC, 60HZ, 9V battery backup
Sensor:	Heat
Audio Alarm:	85dB at 10ft
Temperature Range:	-20F to +100F (-29C and +38C)
Humidity Range:	5%-95% relative humidity (RH)
Size:	5" in diameter x 2" depth
Weight:	.75lbs
Interconnects:	Up to 24 Kidde devices of which 18 can be initiating devices.
LED:	Green, AC power present, alarm mode; flashing Red indicates originating unit
Warranty:	5 year limited warranty

Installation of Heat Alarm

The heat alarm should be installed to comply with all local codes having jurisdiction in your area, Article 760 of the National Electric Code, and NFPA 72. Make certain all alarms are wired to a single, continuous (non-switched) power line, which is not protected by a ground fault interrupter. A maximum of 1000 ft. of wire can be used in the interconnect system.

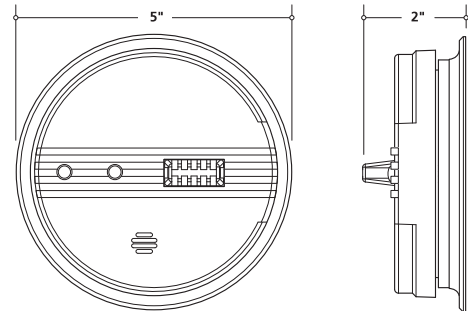

Ordering Information

Gift Box UPC: 0-25417-84135-0

Part Number	1 2 of 5	Pack Quantity	Dimensions (w x d x h inches)	Weight	Case/Skid	Layers/Skid	Skid Weight
HD135F*	N/A	Individual	4.75 x 2.45 x 5.65	.75lbs	N/A	N/A	N/A
HD135F	200 25417 84135 4	Master Pack (6 units)	6.5 x 10.5 x 6.5	4.5lbs	60	5	270lbs

* Not for sale by individual unit



1016 Corporate Park Drive
Mebane NC 27302
1-800-880-6788
www.Kidde.com

Distributed by: