

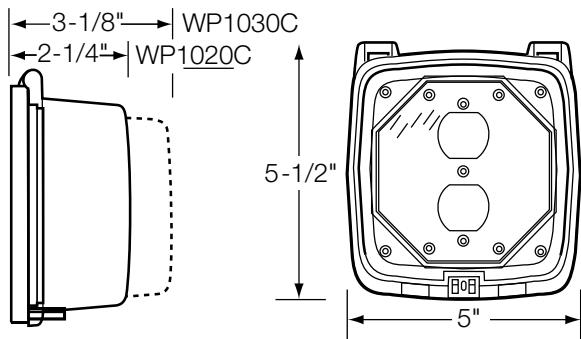

WP1020C

Dimensions



WP1050

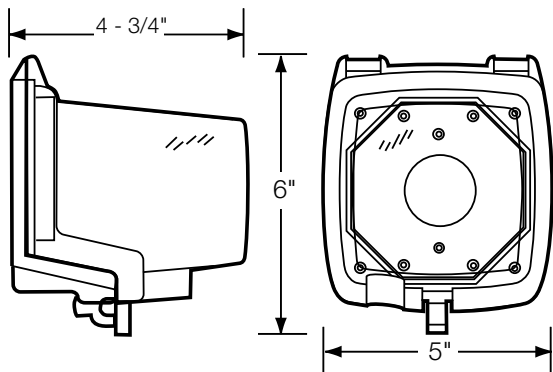

Plastic In-Use Weatherproof Covers

Double-Gang

Plastic In-Use Weatherproof Covers are easy to install and include a gasket, mounting screws, base, cover assembly and inserts to meet the needs of a variety of applications.

Applications

- Industrial • Commercial • Manufacturing • Residential • Agricultural
- Signage • Athletic Fields

Features

- Complies with 2017 NEC Article 314.15 for damp and wet locations
- Exceeds CEC Article 26-702
- UL Certified for Type 3R outdoor enclosures
- Meets requirements for cold impact testing: -60° F (-51° C)
- Heavy-duty UV stabilized polycarbonate cover, mounting base and inserts
- 1/8" (3 mm) thick neoprene gasket with slits for mounting screws
- Two inserts provided with all models for multiple installations
- Max cord size: (2) #14 AWG or (1) #12 AWG, WP1050 (2) #14 AWG or (1) #10 AWG
- Warranty: 1-year limited

Double-Gang - Vertical Hinge



Model #	Color	Depth	Flexi-Guard Inserts
WP1020C	Clear	2 1/4" (57 mm)	WP101, WP102
WP1020GC	Gray	2 1/4" (57 mm)	WP101, WP102
WP1030C	Clear	3 1/8" (79 mm)	WP101, WP102
WP1050	Clear	4 3/4" (121 mm)	WP102, WP107

Accessories (detailed on pg 124)

Double-Gang Duplex Insert	WP101
Double-Gang GFCI Insert	WP102
Double-Gang Insert - Round 1 3/8" (35 mm), 1 5/8" (41 mm), 1 3/4" (44 mm)	WP107
Double-Gang Insert - Round 2 1/8" (55 mm), 2 5/8" (67 mm)	WP213

