

## Plastic In-Use Weatherproof Covers

### Single-Gang Covers

Plastic In-Use Weatherproof Covers are easy to install and include adhered gasket, mounting screws, base, cover assembly and inserts to meet the needs of a variety of applications.

#### Applications

- Industrial • Commercial • Manufacturing • Residential • Agricultural
- Signage • Athletic Fields

#### Features

- Complies with 2017 NEC Article 314.15 for damp and wet locations
- Exceeds CEC Article 26-702
- UL Certified for Type 3R outdoor enclosures
- Meets requirements for cold impact testing: -60° F (-51° C)
- Heavy-duty UV stabilized polycarbonate cover, mounting base and inserts
- 1/8" (3 mm) thick, pre-adhered neoprene gasket with slits for mounting screws
- Three inserts provided with all models that allow each model to meet multiple installations (up to 8 configurations)
- Max cord size: (2) #14 AWG or (1) #12 AWG
- Warranty: 1-year limited



WP1000C



WP1000HC

#### Dimensions

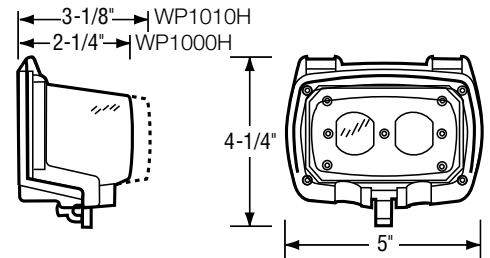
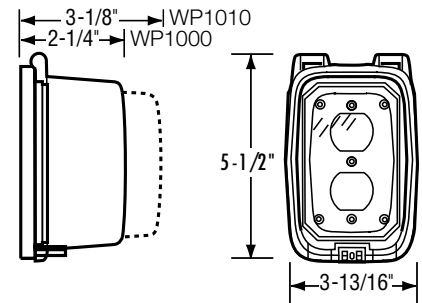

#### Single-Gang - Vertical Hinge



Model #	Color	Depth	Flexi-Guard Inserts
WP1000C	Clear	2 1/4" (57 mm)	WP17
WP1000GC	Gray	2 1/4" (57 mm)	WP17
WP1010C	Clear	3 1/8" (79 mm)	WP17

#### Single-Gang - Horizontal Hinge

Model #	Color	Depth	Flexi-Guard Inserts
WP1000HC	Clear	2 1/4" (57 mm)	WP17
WP1000HGC	Gray	2 1/4" (57 mm)	WP17
WP1010HC	Clear	3 1/8" (79 mm)	WP17
WP1150C	Clear	4 3/4" (121 mm)	WP17

#### Accessories (detailed on pg 124)

Single-Gang Inserts	WP17
---------------------	------

