

SCREW:SEE CHART	MATERIAL:ALUMINUM, X0989	CELL: AMP, ABM	TOLERANCES-UNLESS OTHERWISE SPECIFIED 2 PL. DEC. ±.020 TRUE CL. ±.015 3 PL. DEC. ±.015 ANGLES ≠1	DWG. NO. N7867		
CAT. NO.:SEE CHART	PLATING:WAX	STUFFER SHT.:FORM 18	DRAWN BY:CLH	SCALE: 1:1		SHEET 1 OF 2
MASS:SEE CHART	MARKING: SEE DRAWING		DATE:10/3/2007	SIZE: B		
SURFACE AREA:SEE CHART ²						

REV.	DESCRIPTION

Cat #: PTT-2L-350-Z
PTT-2R-350-Z

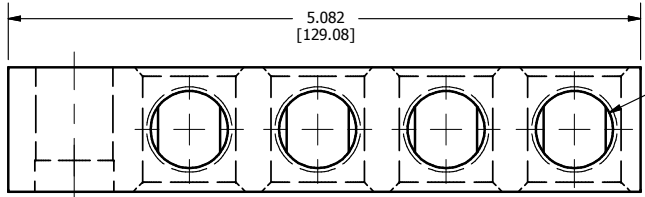

11/16-16 UN - 2B
MUST HOLD Ø.313 PIN
WITH NO LEAD GAGE

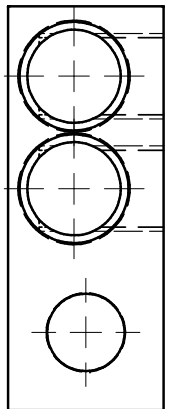
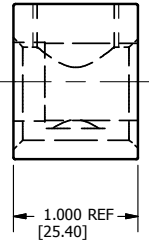
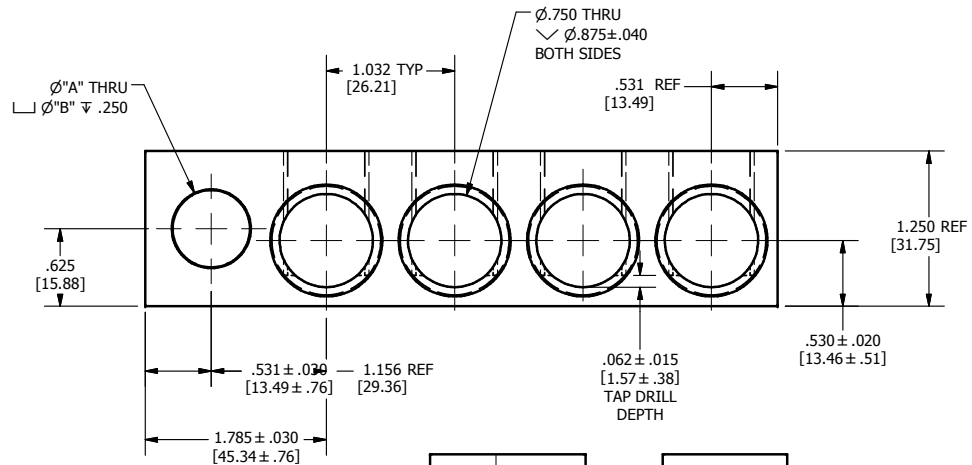
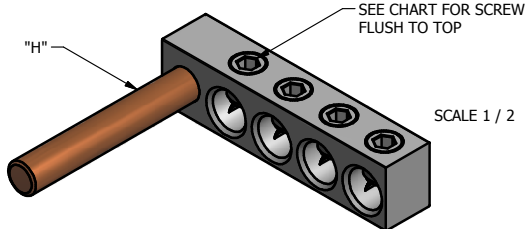

N7867C32WU

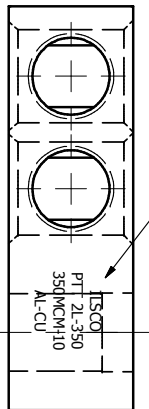

PART NUMBER N7867C32WU
MARKING ONLY

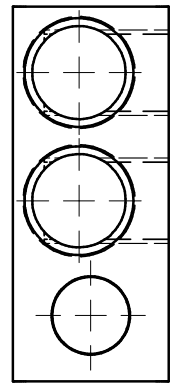

N7867C42WU

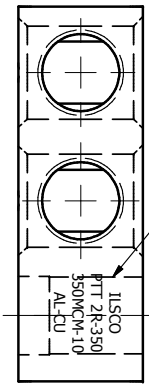

PART NUMBER N7867C42SU
MARKING ONLY