

Combination Gas Controls

VR8245 Intermittent Pilot Combination Gas Control



These universal electronic ignition gas controls are used in gas-fired appliances with capacities up to 150 cu ft/hour at 1 inch wc pressure drop (4.2 cu m/hour at 0.25 kPa) for natural gas. The VR8245M will operate with a direct spark (DSI), hot surface (HSI) or intermittent pilot ignition. The control includes a manual valve, two automatic operators, a pressure regulator, pilot adjustment, pilot plug and ignition adapter.

Type: Single Stage
Body Pattern: Straight-through
Capacity @ 1 in. p.d. 150,000 BTU/hr
Ignition Type: Intermittent Pilot
Pressure Ratings: 1/2 psi (3.5 kPa)

Electrical Ratings: 24 Vac
Frequency: 60 Hz/50 Hz
Mounting: 0 to 90 degrees in any direction from the upright position of the gas control knob, including vertically.

Product Number	Type of Gas	Opening Characteristics (standard, step)	Inlet/Outlet Size (in.)	Pressure Regulator Setting		Ambient Temperature Range		Includes
				(psi)	(kPa)	(F)	(C)	
VR8245M2530	Natural or LP	Standard	1/2 in. x 1/2 in.	3.5 in. wc	0.9 kPa	-40 F to +175 F	-40 C to +79 C	One 1/2 in. x 3/8 in. reducer bushing; Natural to LP Conversion Kit

VR8300 Continuous Pilot Dual Automatic Valve Combination Gas Control

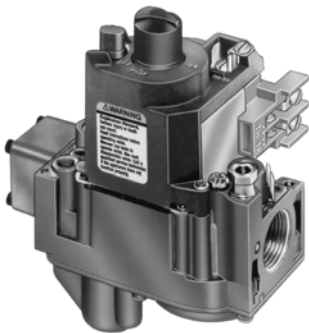

- Controls include safety shutoff, manual valve, two automatic operators, pressure regulator and pilot adjustment.
- Compact size.
- Provide two automatic valves.
- Solenoid operated first automatic valve opens on thermostat call for heat; closes when call for heat ends.
- Diaphragm-operated second automatic valve opens under control of regulator; closes if gas or power supply is interrupted.
- Meets codes requiring dual safety shutoff.
- Standard and slow opening natural gas models include natural to LP gas conversion kit; LP to natural gas conversion kit also available.
- All adjustments, wiring connections and pilot outlet are accessible from top of control.
- Adjustable servo regulator effectively maintains almost constant gas output pressure under wide fluctuations in gas supply pressure.
- Compatible with ECO connector.
- LITE-RITE (OFF-PILOT-ON) lighting sequence.

Combination gas control for use in 24 Vac, gas-fired, standing pilot appliances with capacities from 30 to 300 cfh.

Dimensions in inches (millimeters)

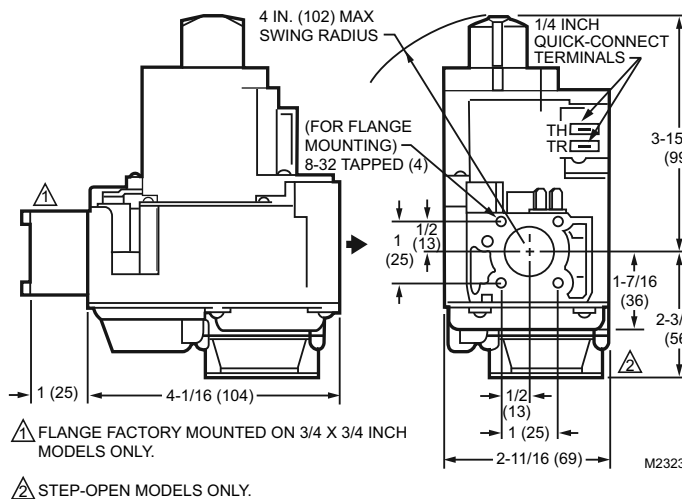

Type: Single Stage
Dimensions, Approximate: 5 3/8 in. high x 4 1/16 in. wide x 2 11/16 in. deep (135 mm high x 104 mm wide x 69 mm deep)
Body Pattern: Straight through with integral tapping; with flange
Capacity @ 1 in. p.d. 190,000 BTU/hr; 30,000 BTU/hr minimum
Anticipator Setting: 0.7 A
Ignition Type: Standing Pilot
Pressure Ratings: 1/2 psi (3.5 kPa)
Pressure Tapping: 1/8 in. NPT with plug
Electrical Ratings: 24 Vac
Frequency: 60 Hz
Pilot Gas Outlet: Compression fitting for 1/4 in. OD tubing
Electrical Connections: 1/4 in. quick-connect male terminals
Mounting: 0 to 90 degrees in any direction from the upright position of the gas control knob, including vertically.

Approvals:
American Gas Association: AGA Design Certified: File No. L2025006.
Canadian Gas Association: CGA Design Certified: File No. L2025006.
Underwriters Laboratories Inc. UL Component Recognized.