

SECTION 3

G-Strut® Fittings & Accessories

General:

G-Strut® fittings and accessories allow the assembly of even complex support and storage designs with basic hand tools.

Material:

Most fittings are made from 1/4" thick carbon steel to an approximated 1-5/8" width to match or accommodate G-Strut® channel products. Note dimensions shown for assembly compatibility.

Finishes:

Standard finish for accessories is electro-galvanized. Consult factory for other finishes.



90° ANGLE FITTINGS

2 HOLE DUCT ANGLE

G344
50/CTN
37 LBS/100

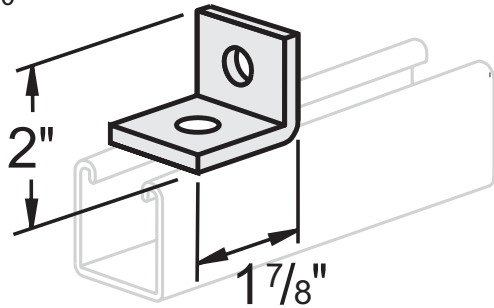

3 HOLE CORNER ANGLE

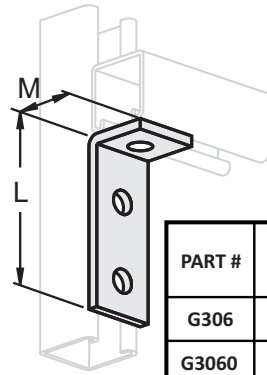

PART #	SIZE (L)	SIZE (M)	CARTON QTY.	LBS./100pcs
G306	4-1/8"	1-5/8"	25	50
G3060	3-7/8"	1-7/8"	50	60
G3064	3-15/16"	1-7/8"	25	51

3 HOLE CORNER ANGLE

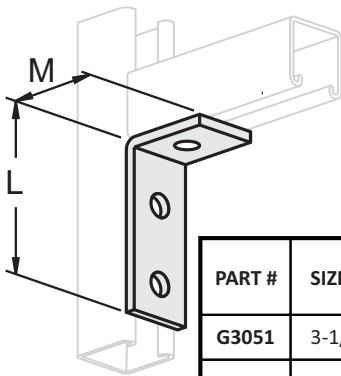

PART #	SIZE (L)	SIZE (M)	CARTON QTY.	LBS./100pcs
G3051	3-1/4"	2"	25	58
G3052	3-1/2"	2-1/4"	25	50

4 HOLE CORNER ANGLE

G311
25/CTN
69 LBS/100

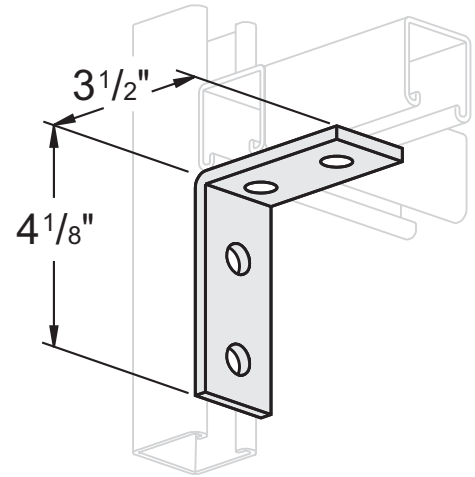

4 HOLE CORNER ANGLE

G3111
25/CTN
68 LBS/100

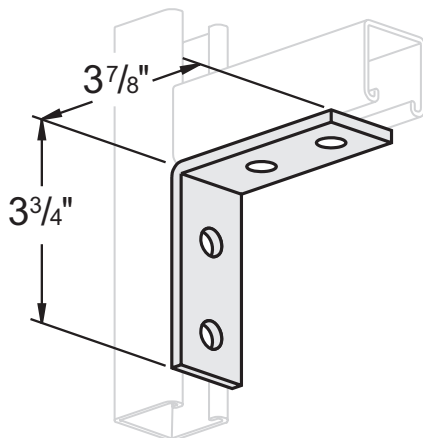

5 HOLE CORNER ANGLE

G3112
25/CTN
75 LBS/100

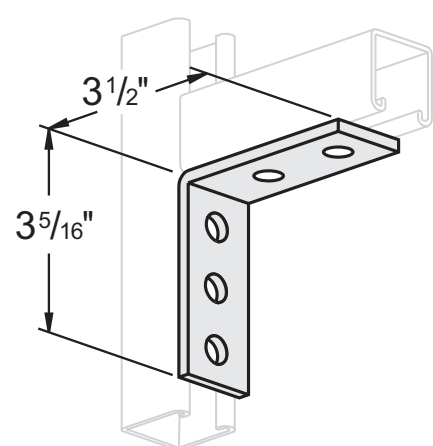

* MATERIAL IS 1-5/8" WIDE x 1/4" THICK UNLESS SPECIFIED • HOLES ARE 9/16" DIAMETER UNLESS SPECIFIED *