

SECTION 3

G-Strut® Fittings & Accessories

General:

G-Strut® fittings and accessories allow the assembly of even complex support and storage designs with basic hand tools.

Material:

Most fittings are made from 1/4" thick carbon steel to an approximated 1-5/8" width to match or accommodate G-Strut® channel products. Note dimensions shown for assembly compatibility.

Finishes:

Standard finish for accessories is electro-galvanized. Consult factory for other finishes.



90° ANGLE FITTINGS

Fittings & Accessories

1 HOLE CORNER ANGLE

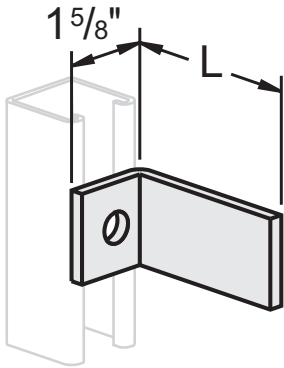

PART #	SIZE (L)	CARTON QTY.	LBS./100pcs
G3061	1-5/8" x 3-7/8"	25	48
G3062	1-5/8" x 5-7/8"	25	83
G3063	1-5/8" x 7-7/8"	25	105
G3065	1-7/8" x 3-7/8"	25	130

2 HOLE CORNER ANGLE

G301
25/CTN
33 LBS/100

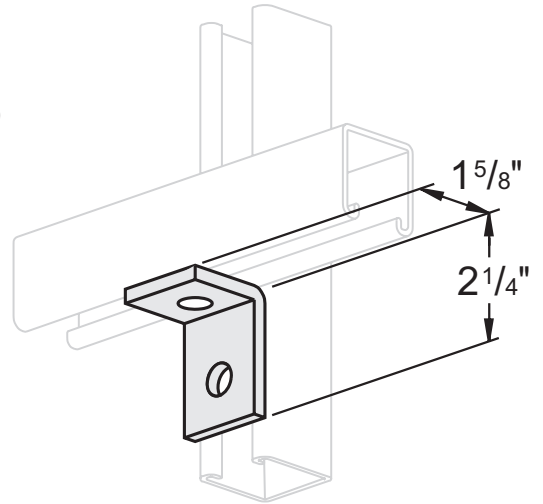

2 HOLE CONNECTION ANGLE

G302
50/CTN
35 LBS/100

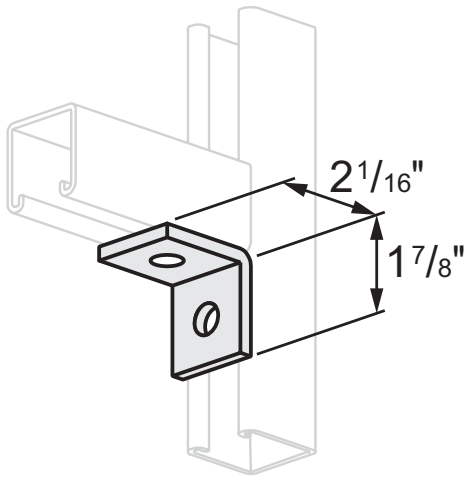

2 HOLE NO-TWIST CORNER ANGLE

G304
50/CTN
37 LBS/100

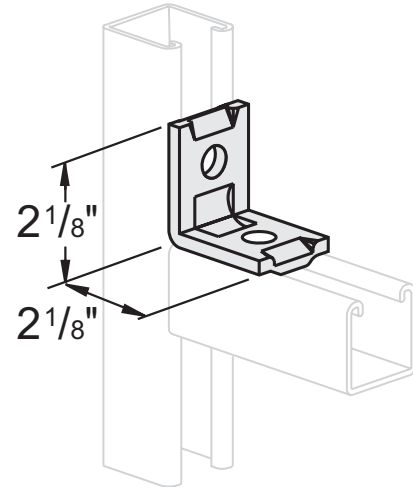

2 HOLE OFFSET ANGLE

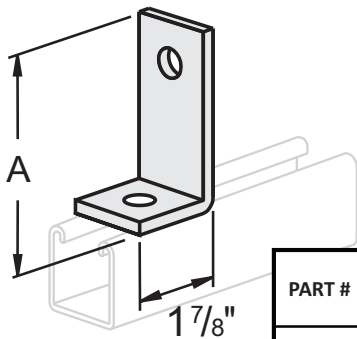

PART #	SIZE (L)	CARTON QTY.	LBS./100pcs
G3381	3"	25	48
G3382	3-1/2"	25	53
G3383	4"	25	61

2 HOLE CORNER ANGLE

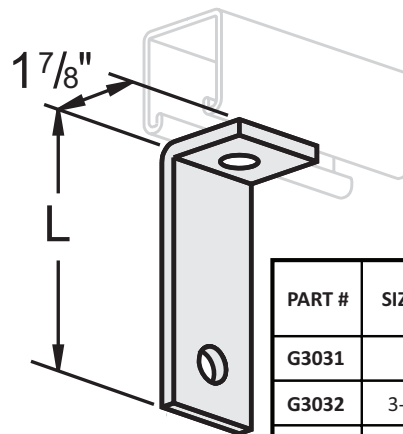

PART #	SIZE (L)	CARTON QTY.	LBS./100pcs
G3031	3"	50	49
G3032	3-1/2"	50	54
G3033	4"	50	61

* MATERIAL IS 1-5/8" WIDE x 1/4" THICK UNLESS SPECIFIED • HOLES ARE 9/16" DIAMETER UNLESS SPECIFIED *