

THE INFORMATION CONTAINED IN THIS DRAWING IS THE SOLE PROPERTY OF GREENFIELD MFG CO ANY REPRODUCTION IN PART OR WHOLE WITHOUT THE WRITTEN PERMISSION OF GREENFIELD MFG CO IS PROHIBITED.

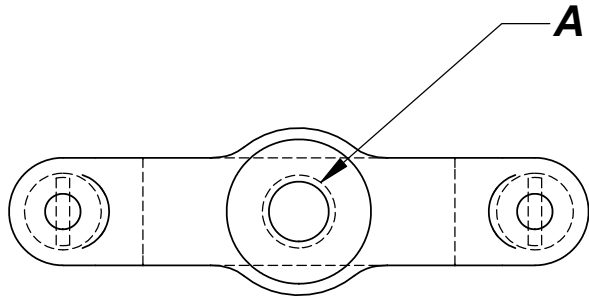

FOR GALVANIZED PIPE

PIPE SIZE	A	B	WT / C APPROX	MAX REC LOAD
3/8	3/8	0.69	10	180
1/2	3/8	0.82	10	180
3/4	3/8	0.94	12	180
1	3/8	1.06	14	180
1-1/4	3/8	1.23	19	180
1 - 1/2	3/8	1.31	21	180
2	3/8	1.62	30	180
2 - 1/2	1/2	1.93	55	300
3	1/2	2.38	80	300
4	1/2	2.87	110	300

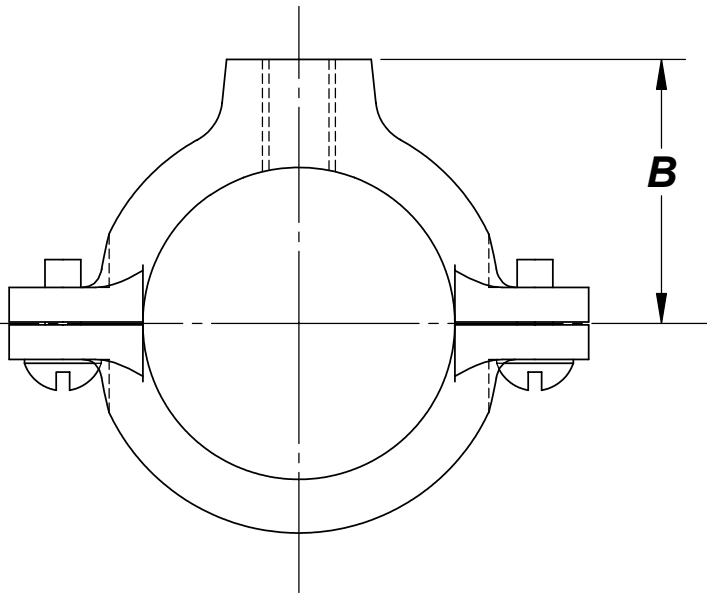

COMPLIES WITH WWH-171D TYP 25

UNLESS OTHERWISE SPECIFIED DIMENSIONS ARE IN INCHES TOLERANCES ARE: FRACTIONS DECIMALS ANGLES +/- 1/8 .XX +/- .03 .XX + 1 .XXX +/- .01	CAD GENERATED DRAWING, DO NOT MANUALLY UPDATE		GREENFIELD MFG CO 920 LEVICK ST , PHILA.,PA. 19111	
	APPROVALS DRAWN EG CHECKED SB	DATE 11/05 11/05	P/N SPLIT RING HANGER	
MATERIAL DUCTILE IRON ZINC PLATED FINISH	SCALE CAD FILE 385.SLDDRW SHEET OF		A FIG 385 REV.	
DO NOT SCALE DRAWING		DO NOT SCALE DRAWING		