

THE INFORMATION CONTAINED IN THIS DRAWING IS THE SOLE PROPERTY OF GREENFIELD MFG CO ANY REPRODUCTION IN PART OR WHOLE WITHOUT THE WRITTEN PERMISSION OF GREENFIELD MFG CO IS PROHIBITED.

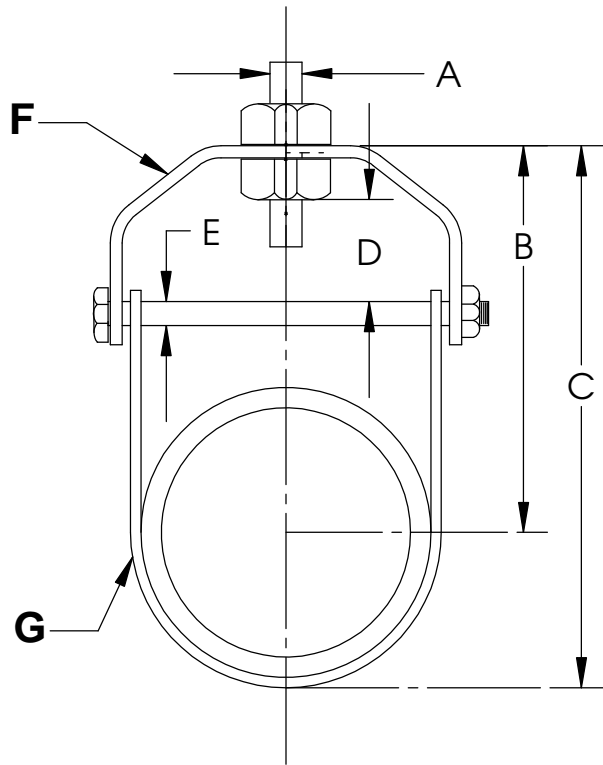

SIZE	A	B	C	D	E	F	G	MAX REC LOAD (lbs)
1/2	3/8	1.7	2.5	0.62	1/4	.080 X 1.00	.070 X 1.00	250
3/4	3/8	2.0	2.8	0.62	1/4	.080 X 1.00	.070 X 1.00	250
1	3/8	2.3	3.0	0.62	1/4	.080 X 1.00	.070 X 1.00	250
1-1/4	3/8	2.5	3.5	0.75	1/4	13 ga X 1.00	.080 X 1.00	250
1-1/2	3/8	2.8	3.8	1.00	1/4	12 ga X 1.00	13 ga X 1.00	250
2	3/8	3.0	4.0	1.30	1/4	12 ga X 1.00	13 ga X 1.00	300
2-1/2	1/2	3.5	5.3	1.30	5/16	11 ga X 1.25	12 ga X 1.25	350
3	1/2	4.8	7.0	2.00	5/16	11 ga X 1.25	12 ga X 1.25	350
4	1/2	5.8	8.0	2.00	3/8	8 ga X 1.25	10 ga X 1.25	500
5	5/8	6.5	9.5	2.30	1/2	3 ga X 1.25	8 ga X 1.25	700
6	5/8	7.5	10.5	2.30	1/2	3 ga X 1.50	8 ga X 1.50	800
8	3/4	8.8	13.0	2.30	9/16	3 ga X 1.75	8 ga X 1.75	1500
10	7/8	10.0	15.0	2.30	3/4	3/8 X 1.75	3 ga X 1.75	2500
12	7/8	11.0	18.0	2.60	3/4	3/8 X 2.00	3 ga X 2.00	3500

Complies with Manufacturers Standardization Society
MSS-SP-58 Type-1 and WWH-171E Type-1

MADE IN USA

UNLESS OTHERWISE SPECIFIED
DIMENSIONS ARE IN INCHES
TOLERANCES ARE:
FRACTIONS DECIMALS ANGLES
+/- 1/8 .XX +/- .03 .XX + 1
.XXX +/- .01

MATERIAL
**STEEL
ZINC PLATED**

DO NOT SCALE DRAWING

CAD GENERATED DRAWING,
DO NOT MANUALLY UPDATE

APPROVALS	DATE
DRAWN EG	5/12
CHECKED SB	

GREENFIELD MFG CO

920 LEVICK ST, PHILA., PA. 19111

CLEVIS -ZINC PLATED

A P/N **FIG 304** B REV.

SCALE CAD FILE **304.SLDDRW** SHEET OF