

THE INFORMATION CONTAINED IN THIS DRAWING IS THE SOLE PROPERTY OF GREENFIELD MFG CO ANY REPRODUCTION IN PART OR WHOLE WITHOUT THE WRITTEN PERMISSION OF GREENFIELD MFG CO IS PROHIBITED.

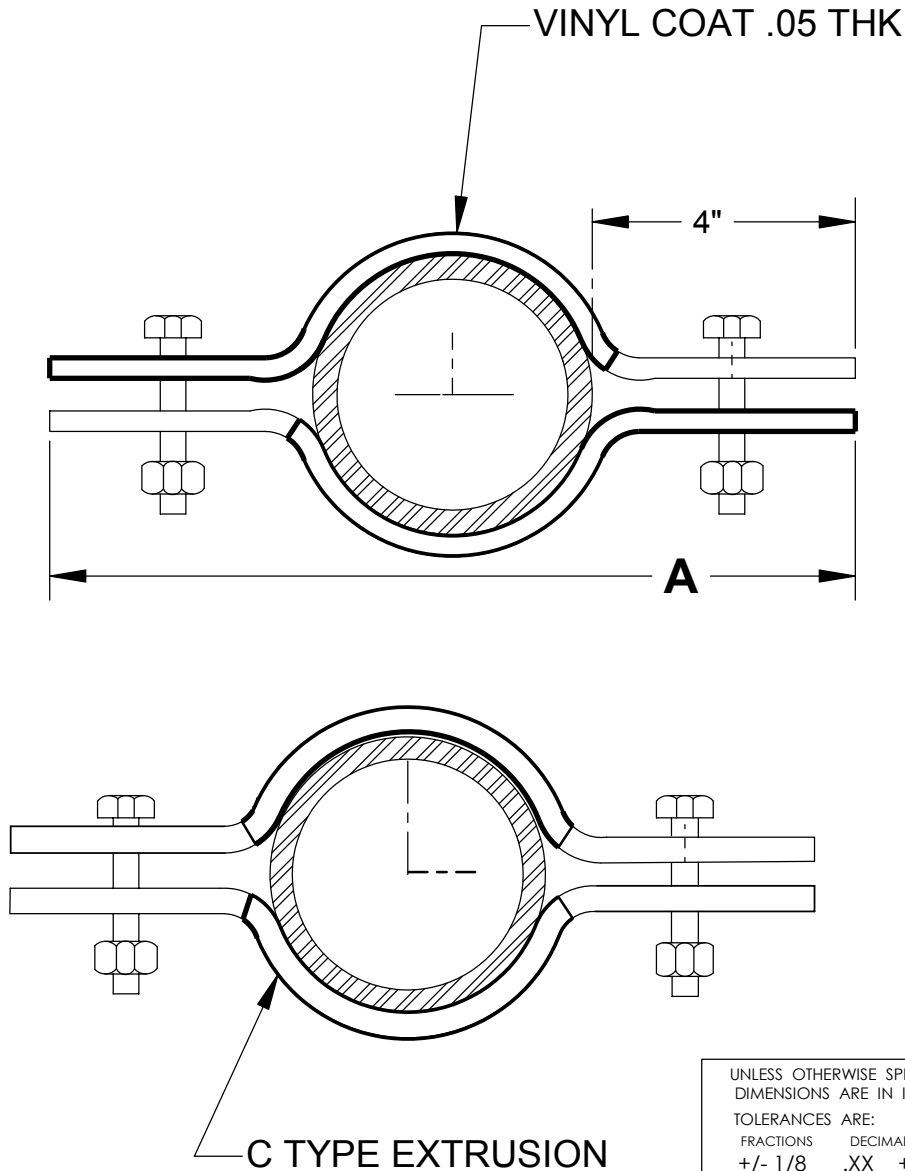

COATING TYPE	SIZE	A	STOCK	BOLT	MAX REC LOAD
EXT	1/2 *	9.00	11 Ga X 1.00	1/4 X 1.25	225
EXT	3/4 *	9.40	11 Ga X 1.00	1/4 X 1.25	225
EXT	1 *	9.50	11 Ga X 1.00	1/4 X 1.25	250
EXT	1-1/4 *	10.00	11 Ga X 1.00	1/4 X 1.25	250
EXT	1-1/2	10.50	11 Ga X 1.00	5/16 X 1.25	250
EXT	2	11.00	10 Ga X 1.00	5/16 X 1.25	250
EXT	3	11.50	9 Ga X 1.00	3/8 X 1.50	300
EXT	4	13.00	8 Ga X 1.00	7/16 X 1.50	400
DIP	5*	14.00	1/4 X 1.25	1/2 X 2.00	750
DIP	6	15.00	1/4 X 1.50	1/2 X 2.00	750
DIP	8	18.50	3/8 X 1.50	5/8 X 2.50	1000

\* = SPECIAL ORDER  
 EXT= C TYPE EXTRUSION APPLIED  
 DIP= VINYL DIPPED

UNLESS OTHERWISE SPECIFIED  
 DIMENSIONS ARE IN INCHES  
 TOLERANCES ARE:  
 FRACTIONS    DECIMALS    ANGLES  
 +/- 1/8    .XX +/- .03    .XX + 1  
               .XXX +/- .01

MATERIAL  
**CQ STEEL**

DO NOT SCALE DRAWING

CAD GENERATED DRAWING,  
 DO NOT MANUALLY UPDATE

APPROVALS	DATE
DRAWN EG	
CHECKED SB	

10/14

**GREENFIELD MFG CO**

920 LEVICK ST , PHILA.,PA. 19111

P/N **PLASTIC RISER CLAMP**

A **FIG 107**

REV.

SCALE CAD FILE: 107.SLDDRW

SHEET OF