

CARBON MONOXIDE ALARM

10-YEAR SEALED



CAT. **C0910B**



10-YEAR LITHIUM POWER

10 years of continuous protection. No battery change required. Provides audible notice when alarm has reached its end of life.

TAMPERPROOF SEALED ALARM

Powercell cannot be removed.

ELECTROCHEMICAL CO SENSOR

Most accurate technology available for detecting carbon monoxide as compared to other sensing technologies.

SILENCE FEATURE

Silences nuisance alarms.

TAMPER RESISTANT

Locks alarm to mounting bracket. Perfect for apartment, dormitory or hotel applications.

Sealed 3V Lithium Power Cell

Description:

BRK Model C0910 is a battery operated, 3V lithium power cell single station CO alarm specifically designed for residential and institutional applications including sleeping rooms of hospitals, hotels, motels, dormitories, and other multifamily dwellings as defined in standard NFPA 101. Model C0910 has been fully tested and complies with, UL2034 CSFM, NFPA 720, NFPA 101 and other agencies that model their codes after the above agencies. It meets building codes where tamperproof 10-year sealed lithium battery operated CO alarms are required and with model building codes published by the ICC.

BRK Model C0910 is a state of the art CO alarm designed to provide early warning of a carbon monoxide danger. It features an electrochemical CO sensor, an 85dB horn, a sealed 10-year lithium power cell power supply that is permanently installed, a full function test switch, a silence feature to silence unwanted nuisance alarms, a red LED light that indicates DC power or alarm. The tamperproof design will not allow the powercell to be removed. The low power warning indicator will cause the alarm to "chirp" when it reaches the end of its service life and needs to be replaced. Upon end of life, the unit meets UL requirements for disabling the alarm and non-reinstallation of unit to mounting bracket. It also features a tamper resistant locking pin that locks alarm to the mounting bracket. Perfect for apartment, dormitory or hotel applications. The compact, low profile design complements any décor. Designed for wall or ceiling mounting. Includes mounting anchors and screws.



CAT. C0910B

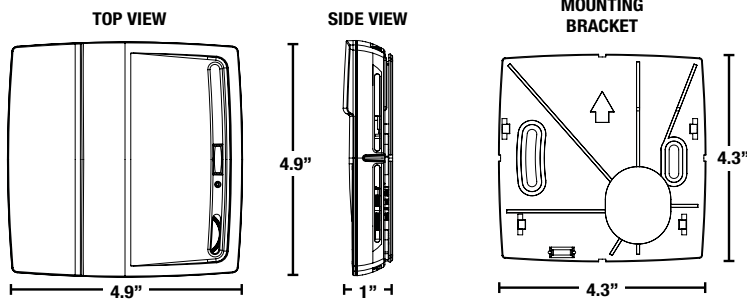

ARCHITECTURAL AND ENGINEERING SPEC

The CO alarm shall be a BRK Model C0910 and shall provide at a minimum the following features and functions:

1. An electrochemical CO sensor.
2. The unit shall be capable of self restoring.
3. Powered by a sealed 10-year lithium powercell with a tamperproof design. The tamperproof design shall not allow the powercell to be removed. A low power warning indicator shall cause the alarm to "chirp" when it reaches the end of its service life and needs to be replaced. Upon end of life, the unit shall meet UL requirements for disabling the alarm and the non-reinstallation of unit to mounting bracket.
4. A visual LED power-on indicator to confirm unit is receiving power or is in alarm.
5. A full function test button. The test button should check all alarm functions by stimulating the chamber to simulate a CO condition, causing the unit to alarm.
6. Two Silence features - Low Battery Silence: Silence low battery chirp for up to 8 hours. Alarm Silence: Temporarily silence unwanted nuisance alarms.
7. A tamper resistant locking pin that locks alarm to the mounting bracket.
8. The unit shall be capable of operating between 40°F (4°C) and 100°F (38°C) and relative humidity between 10% and 90%.
9. The unit shall contain mounting hardware and shall be listed for wall or ceiling mounting.
10. The unit shall at a minimum meet the requirements of UL2034, CSFM, NFPA 720, NFPA 101, ICC.

INSTALLATION OF ALARM

Installation of this smoke alarm must conform to NFPA 720. Always check your local building codes. Follow all instructions for placement as outlined in the user's manual in sections titled "Recommended Locations for CO Alarms" and "Locations to Avoid for CO Alarms".

THE PARTS OF THIS CO ALARM

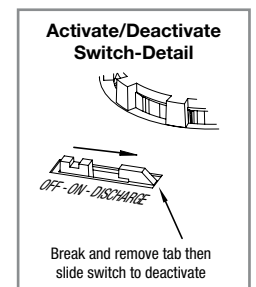
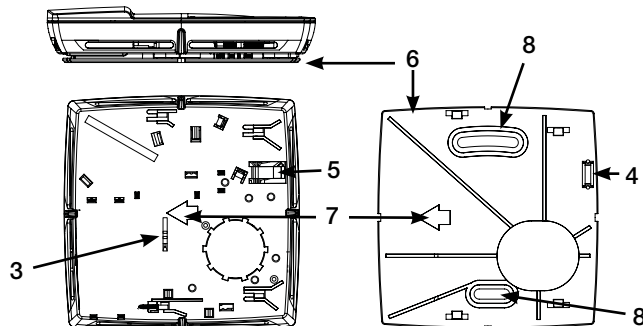
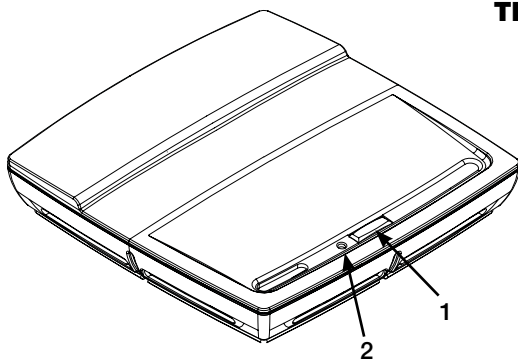

- | | |
|-------------------------------------|------------------------|
| 1. Test/Silence button | 5. Locking tab |
| 2. LED alarm light | 6. Mounting bracket |
| 3. Activate/Deactivate Switch | 7. "This way up" Arrow |
| 4. Locking tab slot (Break out Tab) | 8. Mounting Slots |

TECHNICAL SPECS

Alarm Dimensions:	4.92"L x 4.92"W x 0.96"H
Weight:	4.8 oz
Operating Voltage:	3V Lithium Power Cell
Temperature Range:	40°F (4°C) to 100°F (38°C)
Humidity Range:	10% to 95% relative humidity (RH)
Audio Alarm:	85dB at 10 feet
Test/Silence:	Electronically simulates CO condition, causing the unit to alarm. Press and hold test/silence button.
Alarm Reset:	Automatic when CO clears
CO Sensor:	Electrochemical
Indicator Lights/Sounds:	
DC Power:	Intermittent Red LED
Local Alarm:	Audio Alarm, rapidly flashing red LED
Listing:	Listed to UL2034 Standard

SHIPPING SPECS

Individual Carton Dimensions	4.94 "L x 1.31"D x 6.63"H
Weight	0.4 lbs.
Cube	0.03 ft3
UPC	0 29054 01334 7
Master Carton Dimensions	10.50 "L x 8.13"W x 6.38"H
Master Pack	12
Weight	2.8 lbs.
Cube:	0.32 ft3
I2of5:	200 29054 01334 1
Pallet Information	
Cases per Layer	19
Number of Layers:	8
Cases per Pallet:	152
Units per Pallet:	912
Cube:	62.2 ft3
Weight:	493 lbs.