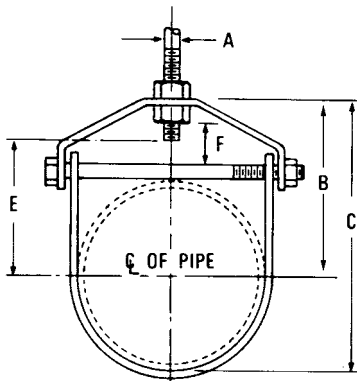

FIG. 11 STANDARD CLEVIS HANGER, DOMESTIC FIG. 11GI STANDARD CLEVIS HANGER, ELECTRO-GALVANIZED



"E" dimension includes exposed rod threads beyond bottom of the hex nut. Exposed rod thread dimension is equal to the diameter of the rod used.



- Material:** Carbon steel, 304 (11SS) and 316 (11SX) stainless steel.
- Finish:** Plain, painted, electro-galvanized, hot dip galvanized.
- Service:** Designed for the suspension of non-insulated, stationary pipe lines.
- Approvals:** U.L. - U.L.C. listed (sizes 2 1/2" - 8") and FM approved (3/4" - 8"). Complies with Federal Specification WW-H-171-E (Type# 1), A-A-1192 A (Type# 1) and Manufacturers' Standardization Society MSS SP-58 and SP-69 (Type# 1).
- Ordering:** Specify pipe size, figure number and finish.
- Notes:** Upper locknut must be tightened securely to assure proper hanger performance. Stainless steel hangers are recommended for applications where protection from corrosive environments is needed.

PIPE SIZE	PIPE OD	MATERIAL SIZE		BOLT	A	B	C	E	F	WGT EACH (lbs)	MAX REC LOAD (lbs)
		TOP	BOTTOM								
1/2	0.840	13ga x 7/8	13ga x 7/8	1/4	3/8	1 11/16	2 1/16	1 5/16	7/16	0.18	610
3/4	1.050	13ga x 7/8	13ga x 7/8	1/4	3/8	1 11/16	2 9/16	1 5/16	7/16	0.18	610
1	1.315	13ga x 7/8	13ga x 7/8	1/4	3/8	2 1/16	2 11/16	1 1/4	5/8	0.22	610
1 1/4	1.660	13ga x 7/8	13ga x 7/8	1/4	3/8	2 1/2	3 3/16	1 11/16	7/8	0.26	610
1 1/2	1.900	12ga x 7/8	12ga x 7/8	1/4	3/8	2 7/8	3 11/16	2 1/16	1 1/16	0.34	610
2	2.375	12ga x 7/8	12ga x 7/8	1/4	3/8	3 5/16	4 7/16	2 1/2	1 1/4	0.38	610
2 1/2	2.875	9ga x 1 3/16	10ga x 1 3/16	5/16	1/2	4 1/2	5 7/8	3 3/8	1 15/16	0.86	1130
3	3.500	9ga x 1 3/16	10ga x 1 3/16	5/16	1/2	4 3/4	6 1/2	3 11/16	1 3/4	0.96	1130
3 1/2	4.000	8ga x 1 3/16	10ga x 1 3/16	5/16	1/2	5 7/8	7 15/16	4 13/16	2 9/16	1.14	1130
4	4.500	8ga x 1 3/16	10ga x 1 3/16	3/8	5/8	5 15/16	8 3/16	4 9/16	2 1/8	1.26	1430
5	5.563	4ga x 1 1/4	8ga x 1 1/4	1/2	5/8	5 11/16	8 7/16	4 5/16	1 7/16	2.04	1430
6	6.625	3ga x 1 1/2	8ga x 1 1/2	1/2	3/4	6 13/16	10 1/8	5 3/16	1 3/4	2.80	1940
7	7.625	3ga x 1 1/2	8ga x 1 1/2	1/2	3/4	7 13/16	11 5/8	6 3/16	2	3.24	2000
8	8.625	3ga x 1 3/4	8ga x 1 3/4	5/8	3/4	8 1/16	12 7/16	6 1/4	1 7/8	4.46	2000
10	10.750	3/8 x 1 3/4	3ga x 1 3/4	3/4	7/8	10	15 7/16	8	2 1/4	8.06	3600
12	12.750	3/8 x 2	3ga x 2	3/4	7/8	11 9/16	18	9 9/16	2 13/16	10.34	3800
14	14.000	1/2 X 2	1/4 X 2	7/8	1	12 9/16	19 9/16	10 9/16	2 9/16	14.80	4200
16	16.000	1/2 X 2 1/2	1/4 X 2 1/2	1	1	13 15/16	21 15/16	11 15/16	2 13/16	21.00	4600
18	18.000	1/2 X 2 1/2	1/4 X 2 1/2	1	1	16	25	13 7/8	3 3/4	24.40	4800
20	20.000	5/8 X 3	3/8 X 3	1 1/4	1 1/4	17 1/2	27 1/2	15 1/8	3 3/4	47.00	4800
24	24.000	5/8 X 3	3/8 X 3	1 1/4	1 1/4	19 3/4	31 3/4	17 3/8	4	54.00	4800
30	30.000	3/4 X 3	3/8 X 3	1 1/4	1 1/4	24 1/8	39 1/8	21 1/2	4 3/4	69.50	6000