

READ AND SAVE THESE INSTRUCTIONS



EMERSON[™]

MIDWAY ECO[™] 54" Ceiling Fan Owner's Manual



Net Weight: 22.1 Lbs.

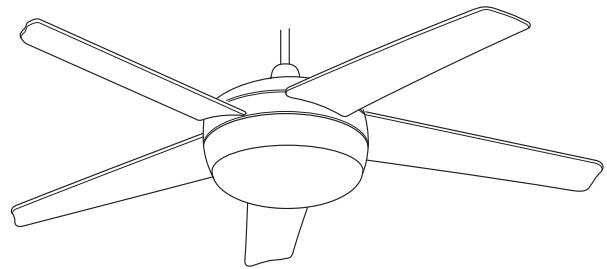

Model No.

**CF955BS 03
CF955ORB 03
CF955WW 03**

LIMITED WARRANTY

What The Warranty Covers:

This warranty covers the motor and the other components and accessories of your Emerson ceiling fan against all defects in workmanship and materials. You must be the original purchaser or user of the product to be covered.

What The Period Of Coverage Is:

As it applies to the motor, this warranty will last for thirty years from the date you purchased your ceiling fan. Repair and replacement of defective parts on the light fixture housing or electronics (excluding the lamp) for two years from the date of purchase. All other components and accessories are covered by this warranty for one year from the date you purchased your ceiling fan. ANY IMPLIED WARRANTY OF MERCHANTABILITY OR FITNESS FOR A PARTICULAR PURPOSE, MADE WITH RESPECT TO COMPONENTS AND ACCESSORIES IS ALSO LIMITED TO ONE YEAR.

What Will Emerson Electric Co. Do To Correct Problems:

Emerson will replace a defective Emerson Air Comfort Ceiling Fan motor, blade, component or other accessory at no charge to you. If repair of the motor or blades is not practical or possible within a reasonable time and no replacement can be provided, Emerson will refund the actual purchase price of your fan. **WE WILL SHIP THE REPAIRED PRODUCT OR REPLACEMENT TO YOU AT NO CHARGE, BUT YOU ARE RESPONSIBLE FOR ALL COSTS OF REMOVAL, REINSTALLATION AND SHIPPING OF THE PRODUCT TO EMERSON.**

How Can You Get Service:

YOU MUST HAVE PROOF OF YOUR PURCHASE OF THE CEILING FAN TO OBTAIN LIMITED WARRANTY SERVICE. KEEP YOUR RECEIPT OR OTHER PROOF OF PURCHASE. You can return the product to our factory or to your nearest authorized service center.

- To return the product to the factory, obtain a return authorization and service identification tag by writing to Air Comfort Products, Division of Emerson Electric Co., 8100 W. Florissant Ave., St. Louis, MO 63136. Include all model numbers shown on the product with your request.
- To return the product to an authorized service center, call 1-800-654-3545 for the address of the nearest authorized service center. You will be responsible for all insurance, freight or other transportation charges to our factory or authorized service center. Your Emerson Air Comfort Ceiling Fan should be properly packed to avoid damage in transit since we will not be responsible for any such damage.

What Is Not Covered:

The glass globes and light bulbs of your ceiling fan are not covered by this warranty. This warranty also does not cover any defects, malfunctions or failures caused by:

- Repairs by persons not authorized by Emerson Electric Co.,
- Use of parts or accessories not authorized by Emerson Electric Co.,
- Mishandling, improper installation, modifications or damage to your ceiling fan while in your possession, or
- Unreasonable use, misuse, abuse, including failing to do reasonable and necessary maintenance, and normal wear and tear.

Additionally, this warranty and any implied warranty of merchantability or fitness for a particular purpose are voided when:

- The original purchaser or user ceases to own the product, or
- The fan is moved from its original point of installation.

This warranty is only valid within the 50 states of the United States and the District of Columbia. No other written or oral warranties apply, and no employee, agent, dealer or other person is authorized to give any warranties on behalf of Emerson Electric Co..

REPAIR, REPLACEMENT OR A REFUND ARE THE EXCLUSIVE REMEDIES AVAILABLE UNDER THIS WARRANTY AND EMERSON IS NOT RESPONSIBLE FOR DAMAGES OF ANY KIND, INCLUDING INCIDENTAL AND CONSEQUENTIAL DAMAGES. Incidental damages include but are not limited to such damages as loss of time and loss of use. Consequential damages include but are not limited to the cost of repairing or replacing other property which was damaged if this product does not work properly.

How State Law Relates To The Warranty:

Some states do not allow the exclusion or limitation of incidental or consequential damages so the above exclusion or limitation may not apply to you. This warranty gives you specific legal rights, and you may also have other rights which vary from state to state.

WARNING/AVERTISSEMENT

WARNING: To avoid fire, shock, and serious personal injury, follow these instructions.

AVERTISSEMENT : suivez ces instructions pour ne pas risquer de causer un incendie, un choc électrique ou des blessures graves.

Safety Instructions

1. Read your owner's manual carefully and keep it for future reference.
2. Before servicing or cleaning unit, switch power off at service panel and lock service panel disconnecting means to prevent power from being switched on accidentally. When the service disconnecting means cannot be locked, securely fasten a warning device, such as a tag, to the service panel.
3. Be careful of the fan and blades when cleaning, painting, or working near the fan. Always turn off the power to the ceiling fan before servicing.
4. Do not put anything into the fan blades while they are turning.
5. Do not operate reversing switch until fan blades have come to a complete stop.

Additional Safety Instructions for Installation

1. To avoid possible shock, be sure electricity is turned off at the fuse box before wiring, and do not operate fan without blades.
2. All wiring must be in accordance with the National Electrical Code "ANSI/NFPA 70-2008" and Local Electrical Codes. Use the National Electrical Code if Local Codes do not exist. The ceiling fan must be grounded as a precaution against possible electrical shock. Electrical installation should be made or approved by a licensed electrician.
3. The outlet box and joist must be securely mounted and capable of reliably supporting at least 50 pounds. Use only U.L. outlet boxes listed as "Acceptable for Fan Support", and use the mounting screws provided with the outlet box. Most outlet boxes commonly used for support of light fixtures are not acceptable for fan support and may need to be replaced. Consult a qualified electrician if in doubt.
4. The downrod furnished with the fan proves the minimum recommended floor to fan blade clearance for an 8 foot ceiling.
5. The fan must be mounted with the fan blades at least 7 feet from the floor to prevent accidental contact with the fan blades.
6. Follow the recommended instructions for the proper method of wiring your ceiling fan. If you do not know enough about electrical wiring, have your fan installed by a licensed electrician.

NOTE: This fan is suitable for use with solid-state speed controls.

WARNING: To reduce the risk of fire or electrical shock, this fan should only be used with fan speed control, Model No. FR-7861LMA, manufactured by Rhine Electric Co., Ltd.

AVERTISSEMENT: pour réduire le risque d'incendie ou de choc électrique, ce ventilateur ne doit être utilisé qu'avec la commande de réglage de la vitesse du ventilateur Modèle N° FR-7861LMA, fabriquée par Rhine Electric Co., Ltd.

WARNING: This product is designed to use only those parts supplied with this product and/or any accessories designated specifically for use this product by Emerson Electric Co. Substitution of parts or accessories not designated for use with this product by Emerson could result in personal injury or property damage.

AVERTISSEMENT: ce produit est conçu pour un emploi exclusif avec les pièces fournies avec ce produit et/ou avec des accessoires désignés spécifiquement pour emploi avec ce produit par Emerson Electric Co. La substitution de pièces ou d'accessoires n'ayant pas été désignés pour emploi avec ce produit par Emerson pourrait causer des blessures ou des dommages matériels.

WARNING: To reduce the risk of personal injury, do not bend the blade flange when installing the blade flanges, balancing the blades or cleaning the fan. Do not insert foreign objects in between rotating fan blades.

AVERTISSEMENT: pour réduire le risque de blessures, ne courbez pas la collerette de pale lors de l'installation, ou lorsque vous équilibrez les pales ou nettoyez le ventilateur. N'insérez pas d'objets étrangers entre les pales du ventilateur en mouvement.

WARNING: To reduce the risk of electrical shock, this fan must be installed with a general use, isolating control/switch.

AVERTISSEMENT: pour réduire le risque de choc électrique, il faut installer ce ventilateur avec un interrupteur/coupe-circuit isolant universel.

DATE CODE: _____

The date code of this fan may be found on the box, stamped in ink on a white label. You should record this data above and keep it in a safe place for future use.

EMERSON QUICK START GUIDE

The Quick Start Guide covers the installation instructions common for ceiling fan operations. If additional assistance with wiring, alternate hanging systems, or lighting options, proceed to the complete instructions of this Owner's Manual.

The Quick Start Guide sections include page numbers to correspond with the appropriate sections of the Owner's Manual for detailed instructions.

* See Unpacking Instructions for a complete list of parts for installation.

⚠ WARNING

To reduce the risk of fire, electric shock, or personal injury, mount fan to outlet box marked "Acceptable for Fan Support", and use screws supplied with outlet box. Most outlet boxes commonly used for support of light fixtures are not acceptable for fan support and may need to be replaced. Consult a qualified electrician if in doubt.

Installation of Downrod (page 76)

1. Remove the hanger ball from the downrod.
2. Install the downrod to the motor coupling using the clevis pin and hairpin clip.
3. Tighten the setscrews.

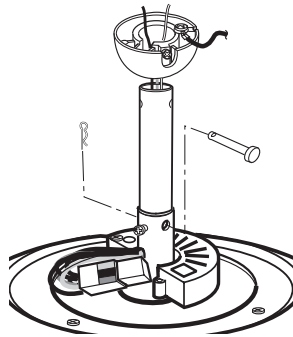

Installation of Ceiling Fan (page 8)

1. Remove the three screws pre-installed on top of the fan assembly. Install the coupler cover and ceiling cover onto the downrod. Reinstall the three screws through the coupler cover.
2. Reinstall the hanger ball onto the downrod, place the pin into the hanger ball and tighten the setscrew.

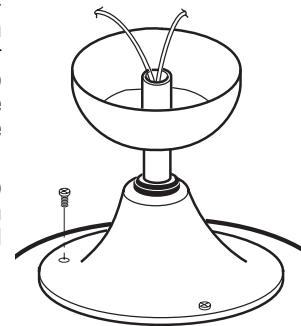

Installation of Blade Assembly (page 8)

1. Turn fan assembly upside down in preparation for mounting fan blade assemblies.
2. To ensure proper blade assembly, make sure the label on the blades are facing the bottom of the ceiling fan. Slide blade through center slot in fan housing. Mount blade to fan housing using three 3/16-24 x 1/2" slotted Phillips washer head blade screws.

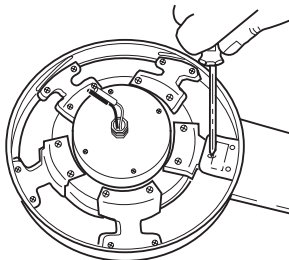

Installation of Switch Housing (page 8)

1. Remove two of the four screws in the motor assembly and loosen the remaining two screws.
2. Connect the terminals of the lower housing assembly to the terminals of the fan motor assembly.

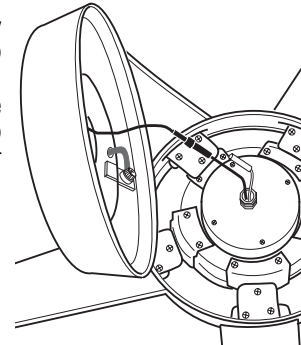

Hanging Your Ceiling Fan (page 10)

1. Disconnect electrical power to the branch circuit at the circuit breaker or fuse box before attempting to install the ceiling fan hanger bracket on the outlet box.

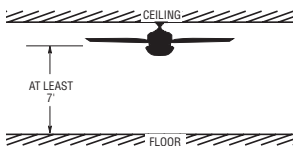

⚠ WARNING

Turning off wall switch is not sufficient. To avoid possible electrical shock, be sure electricity is turned off at the main fuse or circuit breaker box before wiring. All wiring must be in accordance with National and Local codes and the ceiling fan must be properly grounded as a precaution against possible electrical shock.

2. The fan must be hung with at least 7' of clearance from floor to blades.
3. Attach the hanger bracket to the outlet box.
4. Seat the hanger ball/downrod assembly on the hanger bracket.

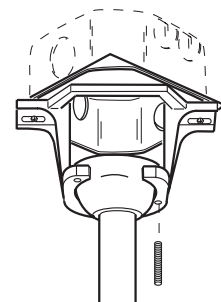

EMERSON QUICK START GUIDE

Wiring Ceiling Fan (page 11)

1. Pull the wire leads, coming from the end of the downrod, and the supply wires through the open side of the hanger bracket.
2. Position the Receiver in the ceiling cover so that the flat side of the receiver faces up and the open portion of the receiver is to the right, as shown.
3. Using wire connectors (supplied), make wiring connections as follows:
 - a. Connect the green ground wires from the hanger bracket and the hanger ball to the supply ground wire (bare or green).
 - b. Connect the white fan to the white supply wire.
 - c. Connect the black fan wire to the black supply wire.

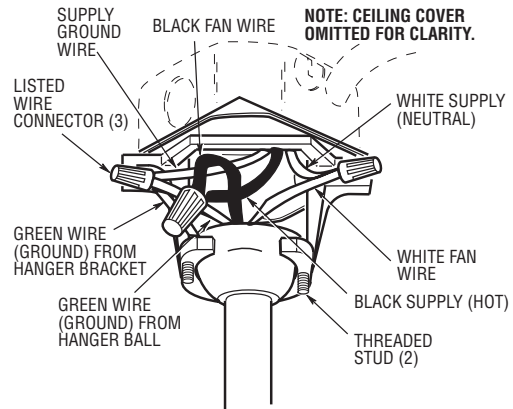

Installation of Ceiling Cover (page 12)

1. After connections have been made, turn leads upward and carefully push leads into the outlet box, with the white and green leads on one side of the outlet box and the black, blue and yellow leads on the other side of the outlet box.
2. Lift the ceiling cover up to the threaded studs and turn until studs protrude through the holes in the ceiling cover.
3. Secure the ceiling cover in place by sliding lockwashers over the threaded studs and installing the two knurled knobs (supplied). Tighten the knurled knobs securely until the ceiling cover fits snugly against the ceiling. Your fan is now wired to be controlled using the remote control transmitter.

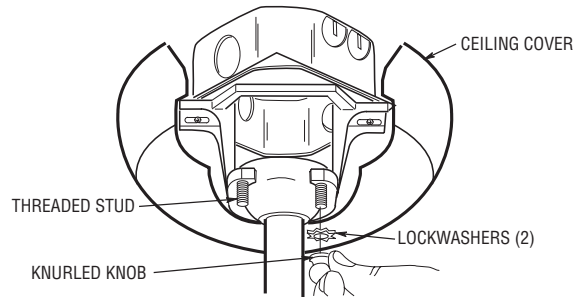

Programming, High Speed Conditioning and Operation of Remote Control (pages 13 and 14)

1. The receiver must be programmed within 2 minutes of restoring electricity to the fan. Program the receiver code by pushing and holding down the remote control OFF button for 3-5 seconds. The ceiling fan lights will blink when the receiver has completed programming.
2. If programming fails, shut off and turn on the electricity at the wall switch to reset the receiver. Repeat Step 1 above.
3. If programming continues to fail, change the remote code and repeat Steps 1 and 2 as necessary until the fan successfully completes the programming procedure.

NOTE: Fan installation must be completed, including the installation of the fan blades, before testing the remote control.

4. Your SR600 Fan/Light remote control has full control of your fan speed, air flow direction and light intensity.

NOTE: The following procedure must be completed.

5. Operate the fan at high speed for 2 minutes. Reverse the fan and operate on high speed 2 additional minutes.

* For additional installation review full instructions on page 13.

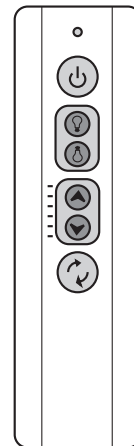

This Manual Is Designed to Make it as Easy as Possible for You to Assemble, Install, Operate and Maintain Your Ceiling Fan

Tools Needed for Assembly

One Phillips head screwdriver One stepladder
 One 1/4" blade screwdriver One wire stripper...

MATERIALS

Wiring outlet box and box connectors must be of type required by the local code. The minimum wire would be a 3-conductor (2-wire with ground) of the following size:

Installed Wire Length	Wire Size A.W.G.
Up to 50 ft.	14
50-100 ft.	12

⚠ WARNING

Before assembly your ceiling fan, refer to section on proper method of wiring your fan (page 11). If you feel you do not have enough wiring knowledge or experience, have your fan installed by a licensed electrician.

⚠ AVERTISSEMENT

Avant d'effectuer le montage de votre ventilateur de plafond, référez-vous à la section consacrée à la méthode de câblage appropriée pour votre ventilateur (page 8). Si vous pensez que vous n'avez pas assez de connaissances ou d'expérience en matière de connexions électriques, demandez à un électricien professionnel d'installer votre ventilateur.

Unpacking Instructions

⚠ WARNING

Do not install or use fan if any part is damaged or missing. Call Toll-Free:

1-800-654-3545

⚠ AVERTISSEMENT

Il ne faut pas installer ou utiliser ce ventilateur si l'un quelconque de ses éléments est endommagé ou manquant. Dans ce cas, appelez ce numéro gratuit :

1-800-654-3545

⚠ WARNING

This product is designed to use only those parts supplied with this product and/or any accessories designated specifically for use with this product by Emerson Electric Co. Substitution of parts or accessories not designated for use with this product by Emerson Electric Co. could result in personal injury or property damage.

⚠ AVERTISSEMENT

Ce produit est conçu pour un emploi exclusif avec les pièces fournies avec ce produit et/ou avec des accessoires désignés spécifiquement pour emploi avec ce produit par Emerson Electric Co. La substitution de pièces ou d'accessoires n'ayant pas été désignés pour emploi avec ce produit par Emerson Electric Co. pourrait causer des blessures ou des dommages matériels.

1. Check to see that you have received the following parts:

NOTE: If you are uncertain of part description, refer to exploded view illustration.

- a. Fan motor assembly
- b. One lower housing assembly
- c. One ceiling cover
- d. Five fan blades
- e. One hanger ball/downrod assembly
- f. One hanger bracket
- g. One glass globe
- h. One fan/light remote control (transmitter)
- i. One coupler cover
- j. Four 13-watt GU-24 fluorescent lamps
- k. One loose parts bag containing:
 1. Sixteen 3/16-24 x 1/2" slotted Phillips washer head blade screws
 2. Three wire connectors
 3. Two 1-1/4" threaded studs
 4. Two lockwashers
 5. Two knurled knobs
 6. One clevis pin
 7. One hairpin clip
 8. One 1.25A 125V fuse (spare)
 9. One 5/32-32 x .375" pan head screw (spare)
 10. One 5/32-32 x .75" slotted head screw (spare)

NOTE: Place the parts from the loose parts bags in a small container to keep them from being lost. If any parts are missing, contact your local retailer or catalog outlet for replacement before proceeding.

Unpacking (continued)

2. Remove the fan assembly from the protective plastic bag. Place the fan assembly into the upper foam pad with the top of the motor facing up.

The upper foam pad serves as a holder for the fan during the first stages of assembly.

Your Emerson ceiling fan comes supplied with a Fan/Light Remote Control which consists of a receiver mounted inside the ceiling cover of the fan motor housing. This system allows you to regulate your ceiling fan speed and light ON/OFF.

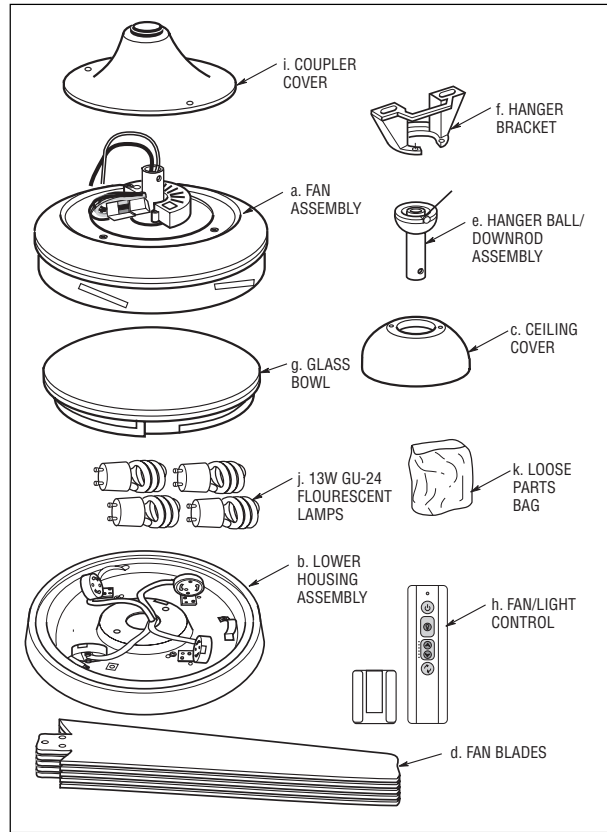

How to Put Your Ceiling Fan Together

1. Remove the hanger ball by loosening the setscrew in the hanger ball until the ball falls freely down the downrod (Figure 1). Remove the clevis pin from the downrod, then remove the hanger ball. Retain the pin and hanger ball for reinstallation in Step 5.
2. Loosen setscrew in motor coupling if necessary. Separate, untwist and unkink the black and white 80" motor leads. Route the motor lead wires through the downrod. Align the clevis pin holes in the downrod with the holes in the motor coupling. Install the clevis pin and secure with the hairpin clip (Figure 2). The clevis pin must go through the holes in the motor coupling and the holes in the downrod. Be sure to push the straight leg of the hairpin clip through the hole near the end of the clevis pin until the curved portion of the hairpin clip snaps around the clevis pin. The hairpin clip must be properly installed to prevent the clevis pin from working loose. Pull on the downrod to make sure the clevis pin is properly installed.

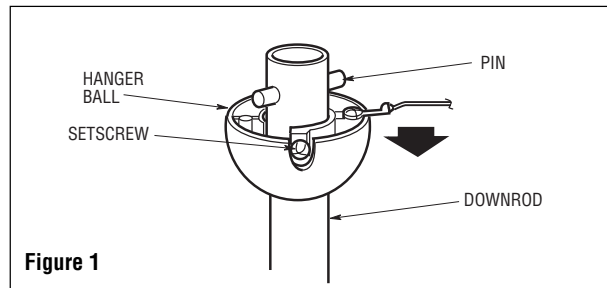

Figure 1

⚠ WARNING

It is critical that the clevis pin in the motor coupling is properly installed and the setscrew securely tightened. Failure to verify that the pin and setscrew are properly installed (as shown in Figure 2) could result in the fan falling.

⚠ AVERTISSEMENT

Il est crucial que l'axe d'assemblage dans l'accouplement du moteur soit installé correctement et que la vis de blocage soit bien serrée. Si vous ne vous assurez pas que l'axe et la vis sont installés correctement (comme cela est illustré à la Figure 2), le ventilateur risquerait de tomber.

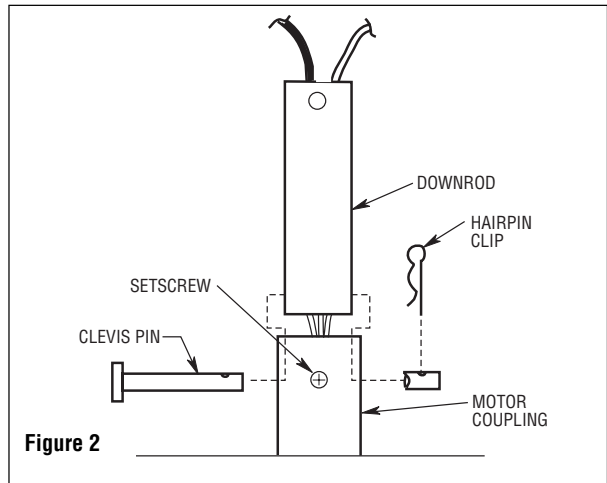

Figure 2

3. While pulling up on the downrod, securely tighten the setscrew in the motor coupling (Figure 3).

NOTE: The setscrew must be properly installed as described above, or fan wobble could result.

4. Remove the three screws pre-installed on top of the fan assembly and retain for use in Step 6.
5. Make sure the grommet is properly installed in the coupling cover then slide the coupler cover on the downrod until it rests on the motor housing. Place the ceiling cover over the downrod. Be sure both the ceiling cover and the coupler cover are oriented correctly (Figure 3).
6. Reinstall the three screws, removed in Step 4, through the coupler cover and into the fan assembly.

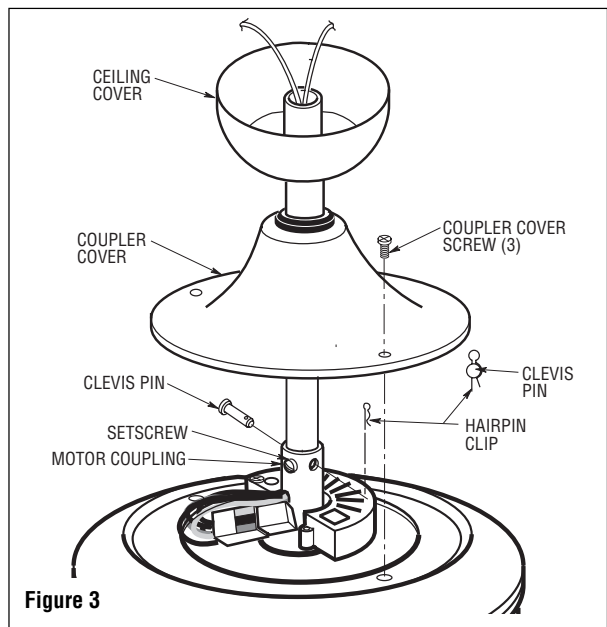

Figure 3

How to Put Your Ceiling Fan Together (continued)

7. Reinstall the hanger ball (Figure 4) on the downrod as follows. Route the motor leads through the downrod. Position the pin through the two holes in the downrod and align the ball so the pin is captured in the groove in the top of the hanger ball. Pull the hanger ball up tight against the pin and securely tighten the setscrew in the hanger ball. A loose setscrew could create fan wobble.

⚠ WARNING

It is critical that the pin in the hanger ball is properly installed and the setscrew securely tightened. Failure to verify that the pin and setscrew are properly installed could result in the fan falling.

⚠ AVERTISSEMENT

Il est crucial que l'axe dans le cylindre de suspension soit installé correctement et que la vis de blocage soit bien serrée. Si vous ne vous assurez pas que l'axe et la vis sont installés correctement, le ventilateur risquerait de tomber.

8. The fan comes with black and white leads that are 80" long. Before installing fan, measure up approximately 6 to 9-inches above top of hanger ball/downrod assembly. Cut off excess leads and strip back insulation 1/2-inch from end of leads.
9. Turn fan assembly upside down in preparation for mounting fan blades.
10. To ensure proper blade assembly, make sure the label on the blades are facing the bottom of the ceiling fan. Slide blade through center slot in fan housing. Mount blades to fan housing using three 3/16-24 x 1/2" slotted Phillips washer head blade screws on each blade (Figure 5).

NOTE: Take care not to scratch fan housing when installing blades.

11. Remove two of the four screws in the motor assembly and loosen the remaining two screws (Figure 6).
12. Connect the terminals of the lower housing assembly to the terminals of the fan motor assembly (Figure 6).

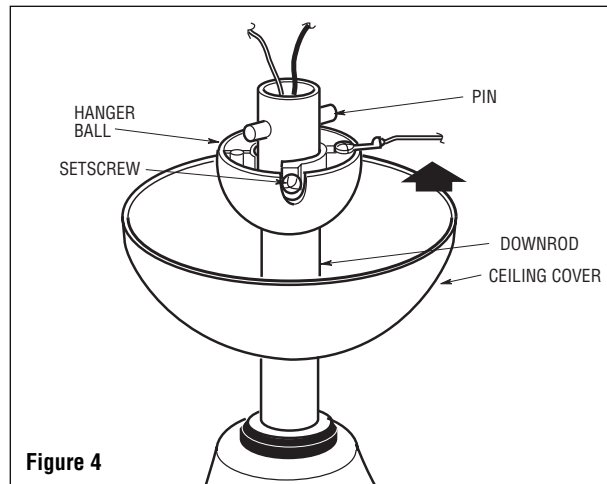

Figure 4

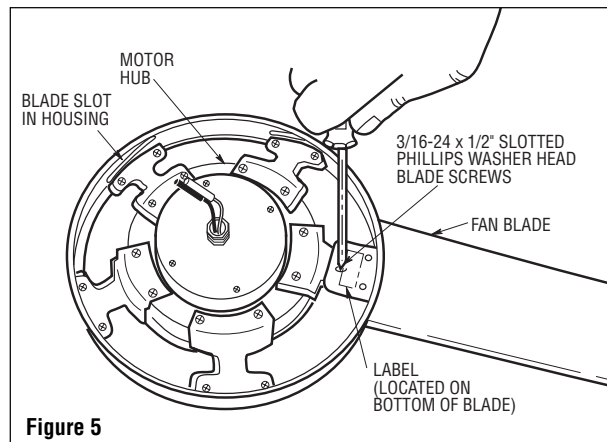

Figure 5

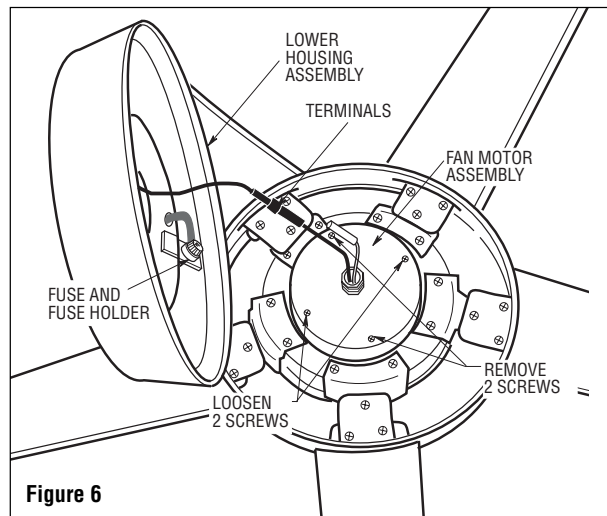
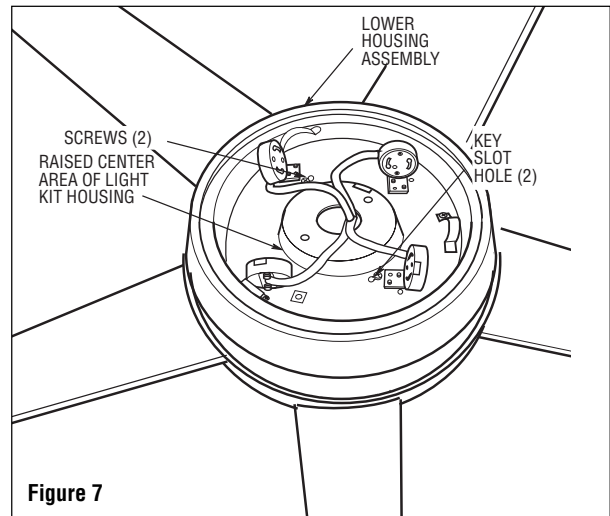

Figure 6

How to Put Your Ceiling Fan Together (continued)

13. Attach the lower housing assembly to the fan motor using the two key slot holes. (Figure 7). Secure the lower housing assembly by tightening the two screws. Reinstall and tighten the two screws that were removed.

NOTE: Make sure wires and terminals are positioned in raised center area of lower housing assembly, and not pinched between fan and light kit.



Electrical Requirements

Your new ceiling fan will require a grounded electrical supply line of 120 volts AC, 60 Hz, 15 amp circuit.

The outlet box must be securely anchored and capable of withstanding a load of at least 50 pounds.

⚠ WARNING

To reduce the risk of fire, electric shock, or personal injury, mount fan to outlet box marked "Acceptable for Fan Support", and use screws supplied with outlet box. Most outlet boxes commonly used for support of light fixtures are not acceptable for fan support and may need to be replaced. Consult a qualified electrician if in doubt.

⚠ AVERTISSEMENT

Pour réduire le risque d'incendie, de choc électrique ou de blessures, ne montez le ventilateur que dans un boîtier de prises de courant comportant les termes « Acceptable pour le raccordement d'un ventilateur », et utilisez les vis fournies avec le boîtier. La plupart des boîtiers de prises de courant utilisés couramment pour le raccordement de luminaires ne sont pas acceptables pour le raccordement de ventilateurs et devront peut-être être remplacés. Consultez un électricien professionnel en cas de doute.

If your fan is to replace an existing ceiling light fixture, turn electricity off at the main fuse box at this time and remove the existing light fixture.

⚠ WARNING

Turning off wall switch is not sufficient. To avoid possible electrical shock, be sure electricity is turned off at the main fuse box before wiring. All wiring must be in accordance with National and Local codes and the ceiling fan must be properly grounded as a precaution against possible electrical shock.

⚠ AVERTISSEMENT

Il n'est pas suffisant de couper l'alimentation au niveau du commutateur mural. Pour éviter tout risque de choc électrique, assurez-vous que l'électricité est coupée au niveau du disjoncteur/boîtier de fusibles avant de commencer le câblage. Tout le câblage doit être conforme aux codes nationaux et locaux, et le ventilateur de plafond doit être mis à la terre de façon correcte pour éviter tout risque de décharge électrique.

⚠ WARNING

To avoid fire or shock, follow all wiring instructions carefully. Any electrical work not described in these instructions should be done or approved by a licensed electrician.

⚠ AVERTISSEMENT

Suivez soigneusement toutes les instructions de câblage pour éviter tout risque d'incendie ou de choc électrique. Tout travail électrique qui n'est pas décrit dans ces instructions doit être effectué ou approuvé par un électricien professionnel.

How to Hang Your Ceiling Fan

⚠ WARNING

The fan must be hung with at least 7' of clearance from floor to blades (Figure 8).

⚠ AVERTISSEMENT

Le ventilateur doit être suspendu de façon que les pales soient au moins à sept pieds (2,10 m) du sol (Figure 8).

⚠ WARNING

The outlet box and joist must be securely mounted and capable of supporting at least 50 lbs. Use only a U.L. outlet box listed as "Acceptable for Fan Support".

⚠ AVERTISSEMENT

Le boîtier de prises de courant et la poutrelle doivent avoir été montées solidement et être capables de supporter au moins 50 lbs (22,5 kg). Utilisez seulement un boîtier de prises de courant homologué U.L. comportant les termes « Acceptable pour le raccordement d'un ventilateur ».

⚠ WARNING

To reduce the risk of fire, electric shock, or personal injury, mount fan to outlet box marked "Acceptable for Fan Support", and use screws supplied with outlet box. Most outlet boxes commonly used for support of light fixtures are not acceptable for fan support and may need to be replaced. Consult a qualified electrician if in doubt.

⚠ AVERTISSEMENT

Pour réduire le risque d'incendie, de choc électrique ou de blessures, montez le ventilateur sur un boîtier de prises de courant comportant les termes « Acceptable pour le raccordement d'un ventilateur », et utilisez les vis fournies avec le boîtier. La plupart des boîtiers de prises de courant utilisés couramment pour le raccordement de luminaires ne sont pas acceptables pour le raccordement de ventilateurs et devront peut-être être remplacés. Consultez un électricien professionnel en cas de doute.

1. Securely attach the hanger bracket to the outlet box using the two screws supplied with the outlet box. (Figure 9.)

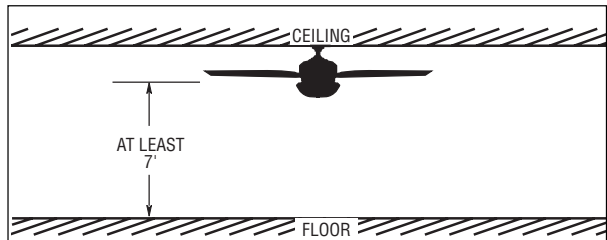

Figure 8

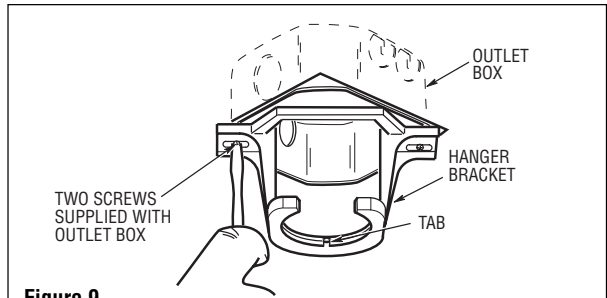

Figure 9

⚠ WARNING

Hanger bracket must seat firmly against outlet box. If the outlet box is recessed, remove wall board until bracket contacts box. If bracket and/or outlet box are not securely attached, the fan could wobble or fall.

⚠ AVERTISSEMENT

Le support de suspension doit reposer fermement contre le boîtier de prises de courant. Si le boîtier de prises de courant est encastré, retirez le panneau de revêtement jusqu'à ce que le support entre en contact avec le boîtier. Si le support et/ou le boîtier ne sont pas solidement attachés, le ventilateur risquerait d'osciller ou même de tomber.

2. Carefully lift the fan and seat the hanger ball/downrod assembly on the hanger bracket that was just attached to the outlet box (Figure 10). Be sure the groove in the ball is lined up with tab on the hanger bracket (Figure 9).

⚠ WARNING

Failure to seat tab in groove could cause damage to electrical wires and possible shock or fire hazard.

⚠ AVERTISSEMENT

Si vous n'installez pas la languette dans la rainure, vous risquez d'endommager les fils électriques et de causer éventuellement une décharge électrique ou un incendie.

How to Hang Your Ceiling Fan (continued)

⚠ WARNING

To avoid possible fire or shock, do not pinch wires between the hanger ball/downrod assembly and hanger bracket.

⚠ AVERTISSEMENT

Pour ne pas risquer d'incendie ou de choc électrique, ne pincez pas les fils entre l'ensemble de tige/cylindre de suspension et le support.

NOTE: CEILING COVER, SUPPLY WIRES AND FAN WIRES OMITTED FOR CLARITY.

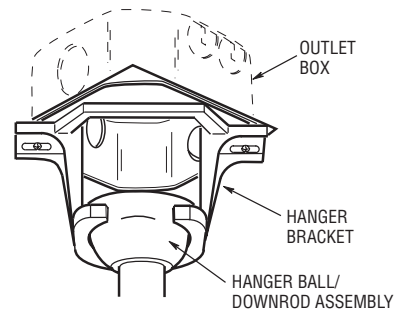

Figure 10

How to Wire Your Ceiling Fan

If you feel that you do not have enough electrical wiring knowledge or experience, have your fan installed by a licensed electrician

⚠ WARNING

To avoid possible electrical shock, be sure electricity is turned off at the main fuse box before wiring.

NOTE: If you are not sure if the outlet box is grounded, contact a licensed electrician for advice, as it must be grounded for safe operation.

⚠ AVERTISSEMENT

Pour ne pas risquer de choc électrique, assurez-vous que l'électricité est coupée au niveau du disjoncteur/boîtier de fusibles avant de réaliser le raccordement.

REMARQUE : si vous ne savez pas vraiment si le boîtier de prises de courant est mis à la terre, contactez un électricien professionnel pour lui demander conseil - le ventilateur doit être mis à la terre pour pouvoir fonctionner sans danger.

1. Connect the green grounding lead from the hanger ball and the green grounding lead from the hanger bracket to the grounding conductor of supply (this may be a bare wire or wire with green colored insulation). Securely connect wires with wire connectors supplied. (Figure 11.)

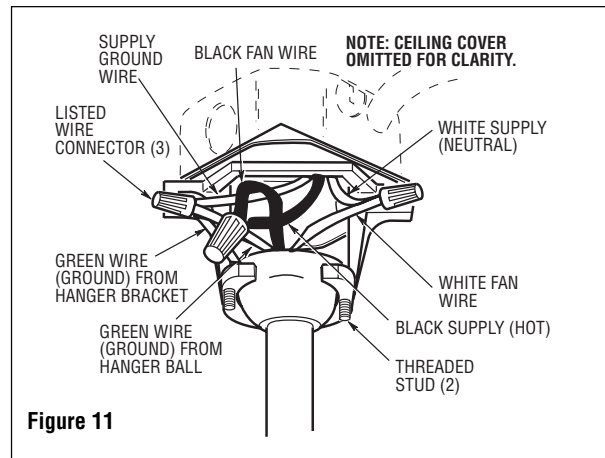

Figure 11

2. Securely connect the fan motor white wire to the supply white (neutral) wire using wire connector supplied (Figure 11). Securely connect the fan motor black wire to the supply black (hot) wire using wire connector supplied (Figure 11).
3. After connections have been made, turn leads upward and carefully push leads into the outlet box, with the white and green leads on one side of the outlet box and the black leads on the other side of the outlet box.

How to Wire Your Ceiling Fan (continued)

⚠ WARNING

Check to see that all connections are tight, including ground, and that no bare wire is visible at the wire connectors, except for the ground wire. Do not operate fan until blades are in place. Noise and fan damage could result.

⚠ AVERTISSEMENT

Effectuez une inspection pour vous assurer que toutes les connexions sont bien serrées, y compris la connexion de mise à la terre, et qu'aucun fil nu n'est visible près des connecteurs, à l'exception du fil de mise à la terre. Ne mettez pas le ventilateur en marche avant que les pales ne soient à leur place. Ceci causerait un fonctionnement très bruyant et risquerait d'endommager le ventilateur.

4. Screw the two threaded studs (supplied) into the tapped holes in the hanger bracket.
5. Lift the ceiling cover up to the threaded studs and turn until studs protrude through the holes in the ceiling cover (Figure 12).
6. Secure the ceiling cover in place by sliding lockwashers over the threaded studs and installing the two knurled knobs (supplied). (Figure 12.) Tighten the knurled knobs securely until the ceiling cover fits snugly against the ceiling and the hole in the ceiling cover is clear of the downrod.

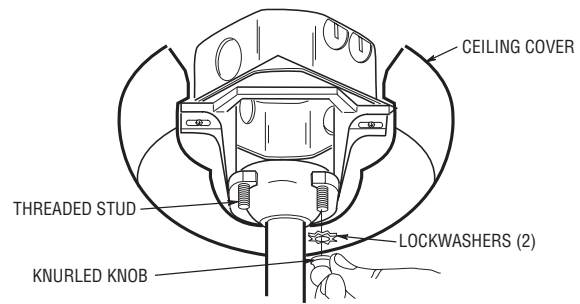

Figure 12

⚠ WARNING

To avoid possible fire or shock, make sure that the electrical wires are completely inside the outlet box and not pinched between the ceiling cover and the ceiling.

⚠ AVERTISSEMENT

Pour ne pas risquer d'incendie ou de choc électrique, assurez-vous que les fils électriques sont complètement à l'intérieur du boîtier de prises de courant et qu'ils ne sont pas pincés entre le revêtement de plafond et le plafond.

Installing Lamps and Glass Globe

1. Carefully position one of the GU24 fluorescent bulbs (supplied) into the light fitter socket, aligning the two pins on the bottom of the bulb into the socket holes. Twist the bulb clockwise, approximately 1/16 turn, to engage the bulb pins into the light socket holes.
2. Install the remaining three GU24 fluorescent bulbs in the same manner.
3. Place the glass bowl into the opening in the lower housing assembly, aligning the three flat areas on the top edge of the glass with the three raised dimples on the lower housing assembly and turn the glass bowl clockwise until it stops (Figure 13).

NOTE: periodically check that the glass bowl is seated fully clockwise in the lower housing assembly.

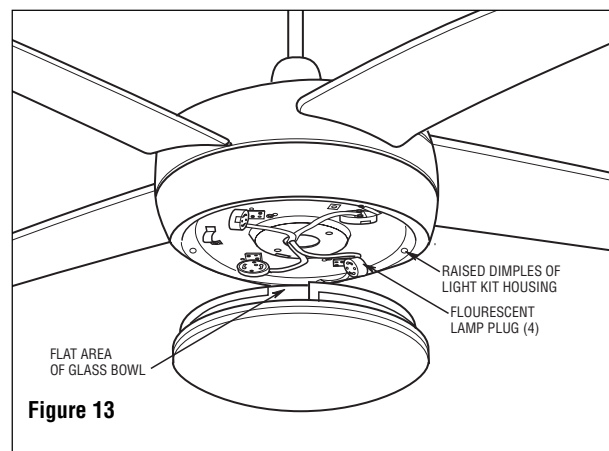

Figure 13

Remote Control Procedures

General

Your Emerson Ceiling Fan/Light Remote Control consists of hand-held transmitter and a receiver which is mounted under the fan ceiling cover. The remote control is designed to separately control your ceiling fan speed and light intensity.

The remote control transmitter is powered by two AAA alkaline batteries (included). To prevent possible damage if the batteries should leak, be sure to remove the batteries when the control is not to be used for an extended period of time.

Code switches in the transmitter and receiver may be set in 32 different positions. If your fan and light go on and off without using your control, you may be getting interference from other remote units such as garage door openers, car alarms or security systems. To remedy this situations, simply change the combination code in your transmitter and receiver.

Preset Memory Feature

Your Emerson receiver is equipped with a preset memory feature. If the AC supply to the receiver is powered through a wall switch, when the switch is turned OFF, the control will remember the light intensity and fan speed. When the switch is turned back ON the light and fan will resume operation as they were prior to the switch being turned OFF.

Installation of Battery

1. Remove the battery cover by pressing firmly below the arrow and sliding the cover off the control (Figure 14).
2. Install two AAA alkaline batteries and reinstall the battery cover.

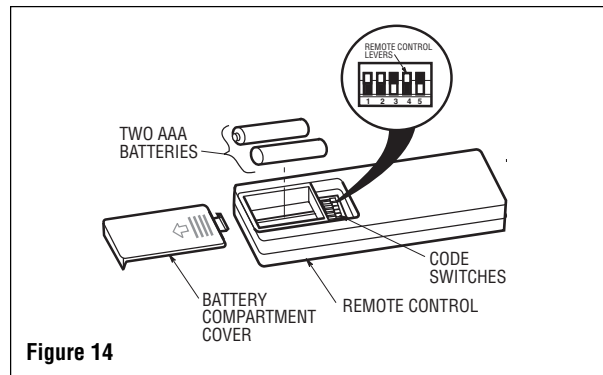

Figure 14

Installation of Storage Bracket for Remote Control

A storage bracket is provided for holding your remote control when not in use. If you desire to use the bracket, install it on a wall that is away from excess heat or humidity (Figure 15).

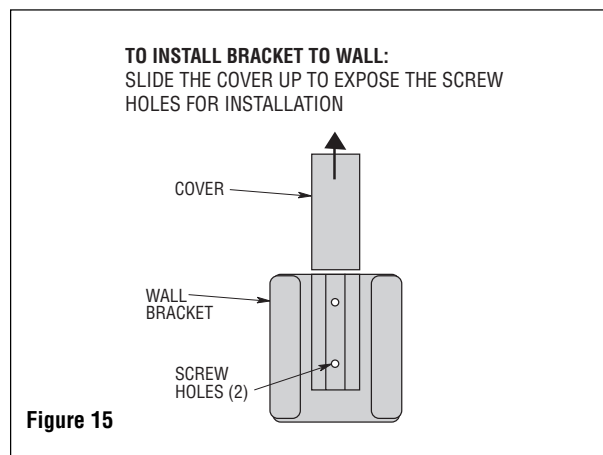

Figure 15

Remote Control Procedures (continued)

Setting Operating Frequency of Remote Control

Your remote control has code switches which must be set in one of 32 possible code combinations (Figure 14). The five levers (numbered 1, 2, 3, 4, and 5) on the switches are factory-set in the ON (up) position. Change the switch settings as follows (Figure 16):

1. Slide the five switch levers in the remote control to your choice of ON (up) or down positions. Use a ball-point pen or small screwdriver and slide the levers firmly up or down.

2. Restore electrical power to the ceiling fan at the circuit breaker panel or fuse box.
3. Within 1 minute of restoring electricity, push and hold the remote control OFF button (⏻) for 3 to 5 seconds to set the code in the receiver. The fan's lights will blink several times to confirm the fan is programmed.

NOTE: The ceiling fan receiver will not respond to transmitter commands if the transmitter's frequency switch settings are changed without reprogramming the receiver. Program the receiver to the new frequency by repeating the "Setting Operating Frequency of Remote Control" and "High Speed Conditioning" instructions.

High Speed Conditioning

IMPORTANT: The following steps must be completed immediately following the frequency programming of the ceiling fan.

1. Press the (⬆) speed button until all 6 LED indicators are lit. Let the fan operate on high speed for 2 minutes without interruption.
2. After 2 minutes, press the reverse (↺) button and allow the fan to operate uninterrupted for 2 minutes at high speed.
3. High speed conditioning is now complete.

Operating Your Ceiling Fan

1. To turn on or shut off the ceiling fan, press and release the (⏻) button.
2. To set the desired fan speed, press the (⬇) button to decrease the speed and the (⬆) to increase the speed. The LED display will light up to indicate the new speed selected.
3. If airflow is desired in the opposite direction, press the (↺) button on the remote control. The fan must be operating at any speed for the reverse button to function. The blades will turn in the opposite direction and reverse the airflow in approximately 30 seconds.
4. To turn the downlight on or off, press and release the (💡) button.

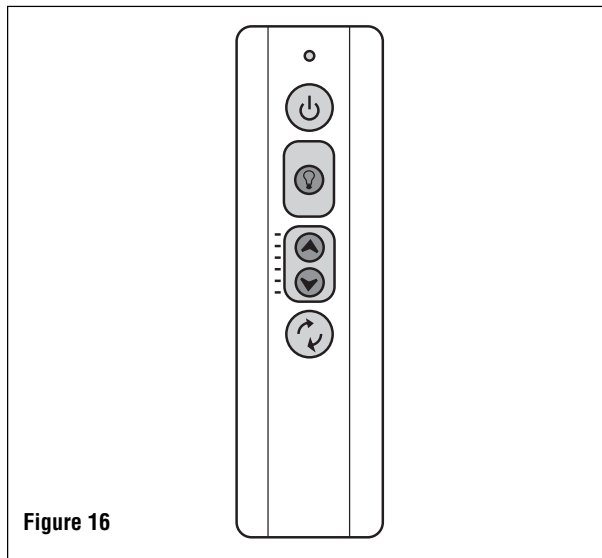

Figure 16

Remote Control Procedures (continued)

Accessory Transmitter Dimming Must Be Turned Off

1. The dimming feature On/Off switch for all accessory transmitters must be set to the "Off" position. Follow your accessory transmitter installation instructions to set the dimming switch to the "Off" position.
2. Attempting to use the transmitter dimming feature will cause the light kit 1.25A fuse to blow. The fuse will need to be replaced to return the lighting to operation.

Maintenance

IMPORTANT CARE INSTRUCTIONS for your Ceiling Fan

Periodic cleaning of your new ceiling fan is the only maintenance that is needed.

When cleaning, use only a soft brush or lint free cloth to avoid scratching the finish.

Abrasive cleaning agents are not required and should be avoided to prevent damage to finish.

WARNING

Do not use water when cleaning your ceiling fan. It could damage the motor or the blades and create the possibility of an electrical shock.

AVERTISSEMENT

N'utilisez pas d'eau lorsque vous nettoyez votre ventilateur de plafond. Cela risquerait d'endommager le moteur ou les lames, et de créer le risque de choc électrique.

Accessories

1. Downrod Extension Kits (see store or catalog).
2. Accessory Ceiling Fan Controls:
 - SR600 - Handheld Transmitter
 - SW605 - Wall Transmitter
 - SR650 - Wall/Handheld Transmitter

WARNING

The use of any other control not specifically approved for this fan could result in fire, shock and personal injury.

AVERTISSEMENT

L'utilisation de toute autre commande non approuvée spécifiquement pour ce ventilateur risquerait de causer un incendie, une décharge électrique ou des blessures.

WARNING

To reduce the risk of fire, electric shock, or personal injury, mount fan to outlet box marked "Acceptable for Fan Support", and use screws supplied with outlet box. Most outlet boxes commonly used for support of light fixtures are not acceptable for fan support and may need to be replaced. Consult a qualified electrician if in doubt.

AVERTISSEMENT

Pour réduire le risque d'incendie, de choc électrique ou de blessures, ne montez le ventilateur que dans un boîtier de prises de courant comportant les termes « Acceptable pour le raccordement d'un ventilateur », et utilisez les vis fournies avec le boîtier. La plupart des boîtiers de prises de courant utilisés couramment pour le raccordement de luminaires ne sont pas acceptables pour le raccordement de ventilateurs et devront peut-être être remplacés. Consultez un électricien professionnel en cas de doute.

Trouble Shooting

⚠ WARNING: FOR YOUR OWN SAFETY TURN OFF POWER AT FUSE BOX OR CIRCUIT BREAKER BEFORE TROUBLE SHOOTING YOUR FAN.

⚠ AVERTISSEMENT : POUR VOTRE PROPRE SÉCURITÉ, COUPEZ L'ALIMENTATION ÉLECTRIQUE AU NIVEAU DES FUSIBLES OU DU DISJONCTEUR AVANT DE TENTER DE RÉPARER VOTRE VENTILATEUR.

TROUBLE	PROBABLE CAUSE	SUGGESTED REMEDY
1. Fan will not start.	1. Fuse or circuit breaker blown. 2. Loose power line connections to the fan. 3. The remote control transmitter battery needs replacement. 4. Fan/Light Remote Control is OFF. 5. Remote is not programmed.	1. Check main and branch circuit fuses or circuit breakers. 2. Check electrical wire connections to fan in the ceiling cover. ⚠ WARNING: Make sure main power is turned off. ⚠ AVERTISSEMENT : assurez-vous que le courant secteur est coupé. 3. Check that the remote transmitter battery is in good condition; the red indicator will illuminate when the key pad buttons are depressed. 4. Turn ON the Fan/Light Remote Control. 5. Program the remote and receiver per the Owner's Manual instructions.
2. Fan sounds noisy.	1. Blades not attached to fan. 2. Screws securing fan flywheel to motor hub are loose. 3. Screws holding blades to flywheel are loose. 4. Glass bowl loose. 5. Hanger bracket and/or ceiling outlet box is not securely fastened.	1. Attach blades to fan before operating. 2. Check to make sure the screws which attach the flywheel to the motor hub are tight. 3. Tighten screws securely. 4. Tighten the glass bowl securely. 5. Tighten the hanger bracket screws to the outlet box, and/or secure outlet box.
3. Fan wobbles excessively.	1. Setscrew in motor coupling is loose. 2. Setscrew in hanger ball/downrod assembly is loose. 3. Screws securing fan flywheel to the motor hub are loose. 4. Screws securing the fan blades to the flywheel are loose. 5. Hanger bracket and/or ceiling outlet box is not securely fastened. 6. Fan blades out of balance.	1. Raise coupler cover and tighten the setscrew securely. 2. Tighten the setscrew in the hanger ball/downrod assembly. 3. Check to be sure the screws which attach the flywheel to the motor hub are tight. 4. Tighten screws securely. 5. Tighten the hanger bracket screws to the outlet box, and/or secure outlet box. 6. Interchanging an adjacent (side-by-side) blade pair can redistribute the weight and result in smoother operation.
4. All four lamps will not illuminate.	1. Loose electrical connectors. 2. The 1.25 amp lamp fuse may have blown and needs replacement. 3. The remote control transmitter battery needs replacement.	1. Shut off the branch circuit electricity at the fuse box or breaker panel and check the receiver electrical connectors for proper installation. ⚠ WARNING: Make sure main power is turned off. ⚠ AVERTISSEMENT : assurez-vous que le courant secteur est coupé. 2. Replace the 1.25 amp fuse with Emerson repair part item 19. See page 5 and reverse the lower housing installation instructions to gain access to the fuse holder. 3. Replace the 12 V battery; recommended replacement 12 V batteries are Duracell MN21, Eveready A23, and GP23A.

Remote Control Trouble Shooting

Fan/Light Fails to Operate

- Check that the speed switch on the fan is set to HIGH (....) speed.
- Check that the wall switch is on.
- Check that the battery is good (red indicator light should light when any button is pressed).
- Check that the remote control has been programmed per page 14 Remote Control Procedures.

INSTRUCTION TO THE USER (if device contains a digital device)

This equipment has been tested and found to comply with the limits for a class B digital device, pursuant to part 15 of the FCC Rules. These limits are designed to provide reasonable protection against harmful interference in a residential installation. This equipment generates, uses and can radiate radio frequency energy and if not installed and used in accordance with the instructions, may cause harmful interference to radio communications. However, there is no guarantee that interference will not occur in a particular installation. If this equipment does cause harmful interference to radio or television reception, which can be determined by turning the equipment off and on, the user is encouraged to try to correct the interference by one or more of the following measures:

- Reorient or relocate the receiving antenna.
- Increase the separation between the equipment and receiver.
- Connect the equipment into an outlet on a circuit different from that to which the receiver is connected.
- Consult the dealer or an experienced radio/TV technician for help.

This equipment has been certified to comply with the limits for a class B computing device, pursuant to FCC Rules. In order to maintain compliance with FCC regulations, shielded cables must be used with this equipment. Operation with non-approved equipment or unshielded cables is likely to result in interference to radio and TV reception. The user is cautioned that changes and modifications made to the equipment without the approval of manufacturer could void the user's authority to operate this equipment.

This Class B digital apparatus meets all requirements of the Canadian Interference-Causing Equipment Regulations.

Repair Parts

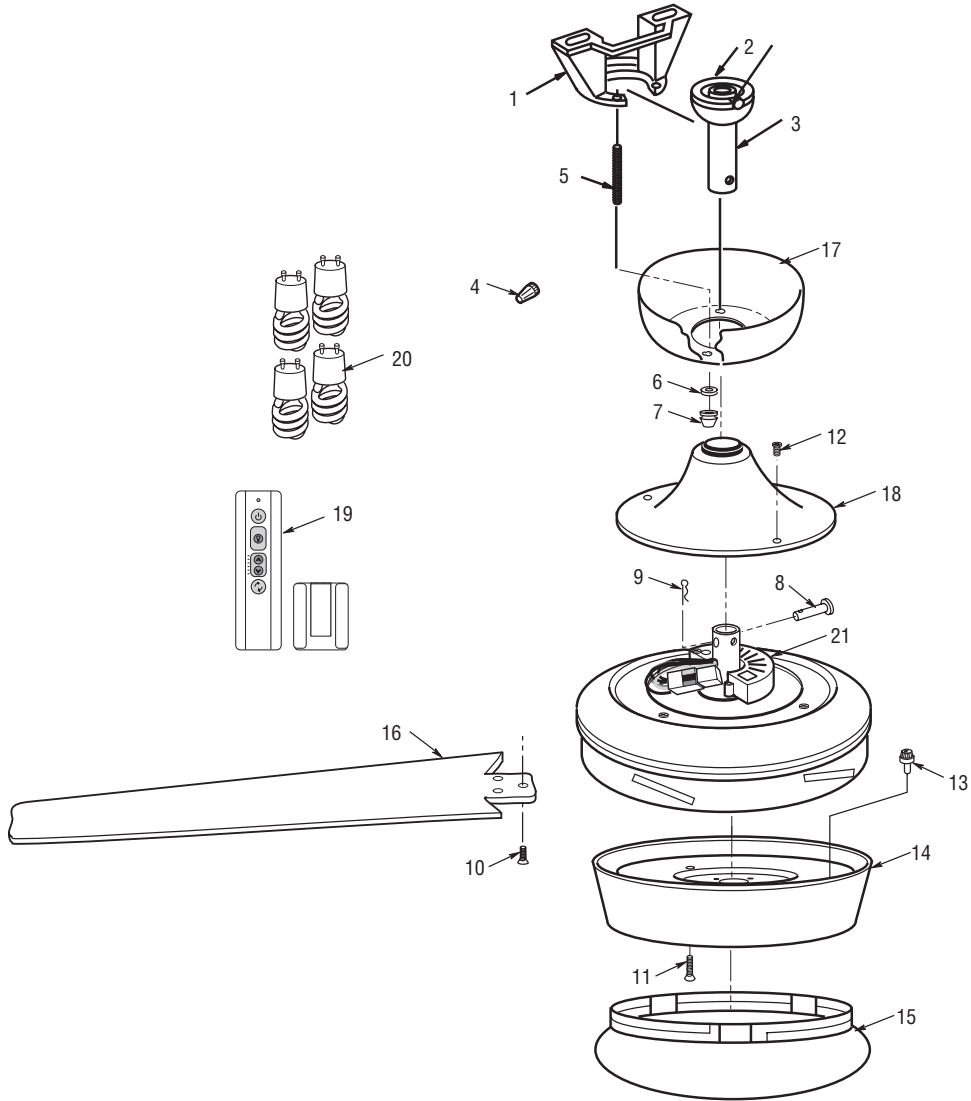

Repair Parts Listing

Key No.	Description	Model Numbers		
		CF955BS 03	CF955ORB 03	CF955WW 03
—	Hanger Ball Assembly, Consisting of:	761655-17	761655-32	761655
1	Hanger Bracket	—	—	—
2	Hanger Ball	—	—	—
3	Downrod	—	—	—
—	Parts Bag Containing:	762029-2	762029-1	762029-2
4	Wire Connector (3)	—	—	—
5	Stud, Threaded, 1-1/4" (2)	—	—	—
6	Lockwashers (2)	—	—	—
7	Knob, Knurled (2)	—	—	—
8	Pin, Clevis	—	—	—
9	Clip, Hairpin	—	—	—
10	Screw, Slotted Phillips Washer Head 3/16-24 x 1/2" (16)	—	—	—
11	Screw, Pan Head 5/32-32 x .375" (spare)	—	—	—
12	Screw, Slotted Head 5/32-32 x .75" (spare)	—	—	—
13	Fuse 1.25A, 125V (spare)	—	—	—
14	Lower Housing Assembly	763746	763746-2	763746-1
15	Glass Shade	762031	762031	762031
16	Blade (set of 5)	762375-3	762375-2	762375-1
17	Ceiling Cover	762534-BS	762534-ORB	762534-WW
18	Coupler Cover	764128-BS	764128-ORB	764128-WW
19	Fan/Light Control	764081	764081	764081
20	GU-24 Fluorescent 13W Lamp	763747	763747	763747
21	Receiver/Motor Control	764080	764080	764080
—	Owner's Manual	BP7373-3	BP7373-3	BP7373-3

**Before discarding packaging material, be certain all parts
have been removed.**

HOW TO ORDER REPAIR PARTS

WHEN ORDERING REPAIR PARTS, ALWAYS GIVE THE
FOLLOWING INFORMATION:

- PART NUMBER
- PART DESCRIPTION
- NAME OF ITEM
- MODEL NUMBER

The model number of your Fan will be found on a label attached to
the top housing.

For repair parts, phone 1-800-654-3545.

LIMITED WARRANTY

What The Warranty Covers:

This warranty covers the motor and the other components and accessories of your Emerson ceiling fan against all defects in workmanship and materials. You must be the original purchaser or user of the product to be covered.

What The Period Of Coverage Is:

As it applies to the motor, this warranty will last for the lifetime of your ceiling fan. All other components and accessories are covered by this warranty for one year from the date you purchased your ceiling fan. ANY IMPLIED WARRANTY OF MERCHANTABILITY OR FITNESS FOR A PARTICULAR PURPOSE, MADE WITH RESPECT TO COMPONENTS AND ACCESSORIES IS ALSO LIMITED TO ONE YEAR.

What Will Emerson Electric Co. Do To Correct Problems:

Emerson Electric Co. will replace a defective Emerson Air Comfort Ceiling Fan motor, blade, component or other accessory at no charge to you. If repair of the motor or blades is not practical or possible within a reasonable time and no replacement can be provided, Emerson will refund the actual purchase price of your fan. **WE WILL SHIP THE REPAIRED PRODUCT OR REPLACEMENT TO YOU AT NO CHARGE, BUT YOU ARE RESPONSIBLE FOR ALL COSTS OR REMOVAL, REINSTALLATION AND SHIPPING OF THE PRODUCT TO EMERSON ELECTRIC CO.**

How Can You Get Service:

YOU MUST HAVE PROOF OF YOUR PURCHASE OF THE CEILING FAN TO OBTAIN LIMITED WARRANTY SERVICE. KEEP YOUR RECEIPT OR OTHER PROOF OF PURCHASE. You can return the product to our factory or to your nearest authorized service center.

- To return the product to the factory, obtain a return authorization and service identification tag by writing to Air Comfort Products, Division of Emerson Electric Co., 8100 W. Florissant Ave., St. Louis, MO 63136. Include all model numbers shown on the product with your request.
- To return the product to an authorized service center, call 1-800-654-3545 for the address of the nearest authorized service center.

You will be responsible for all insurance, freight or other transportation charges to our factory or authorized service center. Your Emerson Air Comfort Ceiling Fan should be properly packed to avoid damage in transit since we will not be responsible for any such damage.

What Is Not Covered:

The glass globes and light bulbs of your ceiling fan are not covered by this warranty. This warranty also does not cover any defects, malfunctions or failures caused by:

- Repairs by persons not authorized by Emerson Electric Co.,
- Use of parts or accessories not authorized by Emerson Electric Co.,
- Mishandling, improper installation, modifications or damage to your ceiling fan while in your possession, or
- Unreasonable use, misuse, abuse, including failing to do reasonable and necessary maintenance, and normal wear and tear.

Additionally, this warranty and any implied warranty of merchantability or fitness for a particular purpose are voided when:

- The original purchaser or user ceases to own the product, or
- The fan is moved from its original point of installation.

This warranty is only valid within the 50 states of the United States and the District of Columbia. No other written or oral warranties apply, and no employee, agent, dealer or other person is authorized to give any warranties on behalf of Emerson Electric Co.

REPAIR, REPLACEMENT OR A REFUND ARE THE EXCLUSIVE REMEDIES AVAILABLE UNDER THIS WARRANTY AND EMERSON IS NOT RESPONSIBLE FOR DAMAGES OF ANY KIND, INCLUDING INCIDENTAL AND CONSEQUENTIAL DAMAGES. Incidental damages include but are not limited to such damages as loss of time and loss of use. Consequential damages include but are not limited to the cost of repairing or replacing other property which was damaged if this product does not work properly.

How State Law Relates To The Warranty:

Some states do not allow the exclusion or limitation of incidental or consequential damages so the above exclusion or limitation may not apply to you. This warranty gives you specific legal rights, and you may also have other rights which vary from state to state.



EMERSON

Air Comfort Products

DIVISION OF EMERSON ELECTRIC CO.
8100 W. Florissant • St. Louis, MO 63136