

Slimlyte Plus (SLP)

POST PAINTED

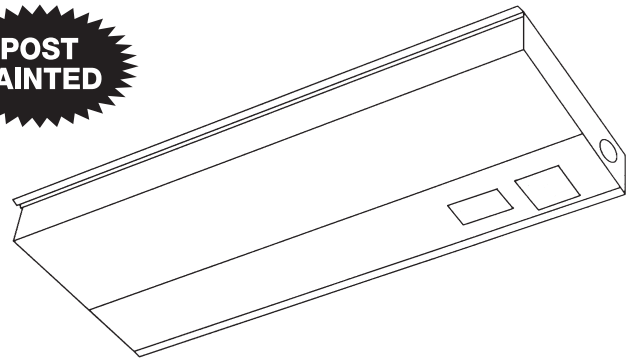

ORDERING INFORMATION

Catalog Number: Example: SLP113

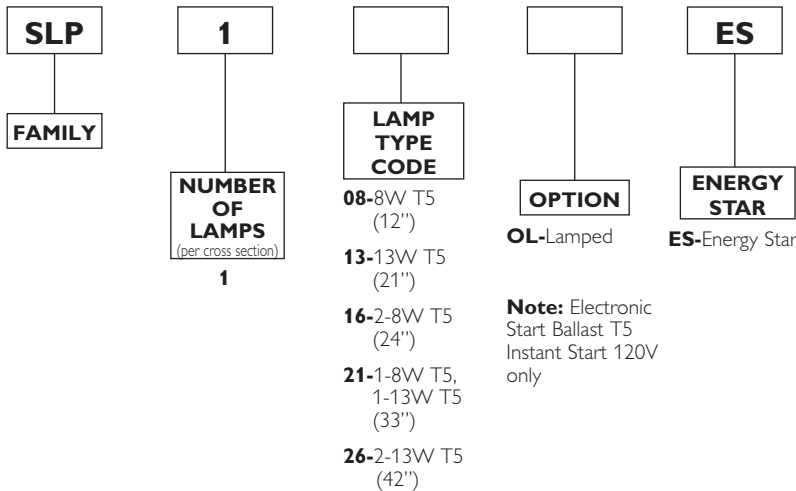

PRODUCT FEATURES

- 1 1/8" ultra-slim styling creates unobtrusive hidden light source for a variety of task lighting applications.
- Electronic start ballast eliminates starter while providing the user with instant light.
- Complete with 7/8" low profile snap-in connector that facilitates in and out wiring.
- Post painting after fabrication insures high quality finish.
- Electrical fitting included to accept flexible conduit or romex.
- Damage-resistant white acrylic lens reduces glare factor.
- Optional rocker type switch and grounded convenience outlet available as field installed accessories.
- Contractor-friendly SnapTyte assembly.

PRODUCT AVAILABILITY

FAMILY	NUMBER OF LAMPS (per cross section)	NUMBER OF LAMPS (per fixture)	LAMP TYPE CODE	LENGTH	WIDTH	HEIGHT
SLP	1	1	08	12 1/4"	5"	1 1/8"
SLP	1	1	13	21 1/4"	5"	1 1/8"
SLP	1	2	16	24 1/2"	5"	1 1/8"
SLP	1	2	21	33 1/2"	5"	1 1/8"
SLP	1	2	26	42 1/2"	5"	1 1/8"

DIMENSIONS

All K.O.s are 1/2" dia.

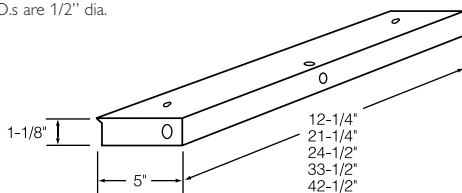

Dimensions and specifications subject to change without notice.

SPECIFICATIONS

Housing is die-formed of cold rolled steel with adequate knock-out locations for all normal installation methods. All metal components are phosphate coated and post painted in baked white enamel providing a minimum reflectance factor of 85%. Lens is non-yellowing poly-acrylic. Optional rocker type switches and grounded convenience outlets are available upon request. All fixtures are UL-listed and bear union and UL labels. Standard voltage is 120 volts 60 Hz.