

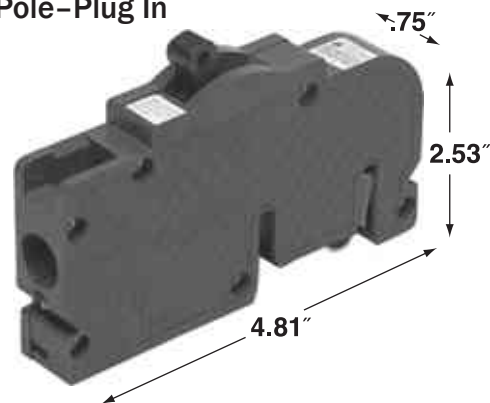

# of Poles	AMP Rating	Catalog Number	Price	UPC
1	15	UBIZ15 (Q15)		0 94925 03038 9
1	20	UBIZ20 (Q20)		0 94925 03039 6
1	30	UBIZ30 (Q30)		0 94925 03040 2
1	40	UBIZ40 (Q40)		0 94925 00344 4
1	50	UBIZ50 (Q50)		0 94925 00345 1
Sleeve Count: 6 Case Count: 24		‡SWD Rating applies to the switching of 15 & 20 amp fluorescent lighting circuits only!		
Catalog numbers in parentheses denote former Zinsco® part numbers.				
2	15	UBIZ215 (QC15)		0 94925 03029 7
2	20	UBIZ220 (QC20)		0 94925 03041 9
2	30	UBIZ230 (QC30)		0 94925 03042 6
2	40	UBIZ240 (QC40)		0 94925 03043 3
2	50	UBIZ250 (QC50)		0 94925 03044 0
2	60	UBIZ260 (QCAL60)		0 94925 03045 7
2	70	UBIZ270 (QCAL70)		0 94925 41812 5
2	80	UBIZ280 (QCAL80)		0 94925 41813 2
2	90	UBIZ290 (QCAL90)		0 94925 41814 9
2	100	UBIZ2100 (QCAL100)		0 94925 03046 4
2	125	UBIZ2125 (QCAL125)		0 94925 41815 6

Sleeve Count: 3  
Case Count: 72

### Thick Series One Pole-Plug In



Requires One 3/4" Space  
SWD Rated† 120/240VAC  
10,000 AIC  
Corresponds to Zinsco® Q Series

### Thick Series Two Pole-Plug In

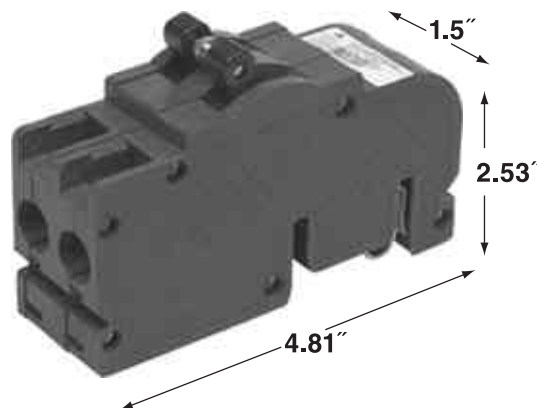

Requires Two 3/4" Spaces  
HACR 120/240VAC  
10,000 AIC  
Corresponds to Zinsco® QC Series