



Solid Plastic Seat Elongated

Institutional • Commercial

500 SERIES



DETAILS

AM500STSCSS

Heavy Duty, open front less cover for elongated bowl. Self sustaining stainless steel check hinge.

Standard Features:

- Corrosion free steel hinge posts
- Extended back with concealed hinge
- Integrally molded permanent and sanitary colour keyed bumpers
- Corrosion free hardware
- Withstands cleansers, strong chemicals
- Easy clean

U.S :

Antimicrobial additive inhibits the growth of stain and odor causing bacteria on the surface.

Canada :

Contains CESA-MB8233 as a preservative for the protection of this article.

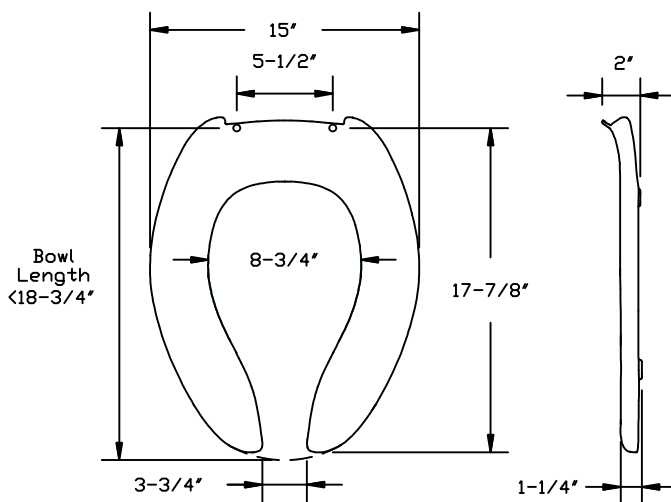

Dimensions shown are nominal and may vary within a range of tolerance.