

Central Brass

C O M P A N Y

Brecksville, Ohio 44141

Phone: (216) 883-0220 Fax: (440) 526-5745

www.CentralBrass.com

6056 6076
6086-Z 6266
TWO-VALVE
BATH/SHOWER FITTING

6" Centers, I.P. Unions, Compression Stems, Replaceable Seats

- 6056 Series** Bath Valve only
- 6076 Series** Bath & Shower Valve same as 6066 with Shower Head, Arm & Flange
- 6086 Series** Bath Filler Valve with 1/2 IPS Diverter Spout
- 6266 Series** Shower Valve with Shower Head, Arm & Flange

The 2-valve bath and shower fitting is made with a cast brass body with replaceable seats designed for union connections on 6-inch centers. The stem units are all brass with a reinforced rubber packing and rubber seat washer. The stem units can be easily replaced from the front of the fitting without removing the valve body. The valve is supplied with a twin ell that connects the valve to the chrome plated diverter spout and the shower tube. The handles, spout and escutcheons are zinc die cast with a chrome plated finish. The shower arm is brass with a chrome plated finish, the escutcheon is stainless steel and the shower head is chrome plated plastic. Direct sweat union sleeves (C suffix) are available.



ASME A112.18.1M

Shower Flow Rate

2.5 gpm @ 80 psi

I
n
s
t
r
a
l
l
i
n
g
o
n

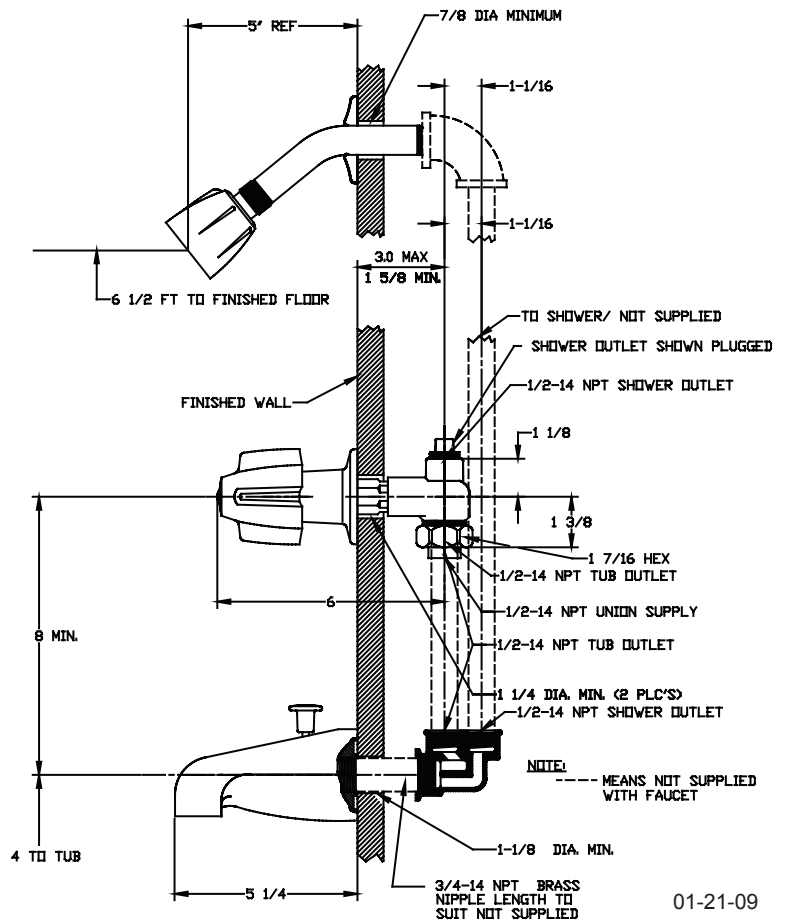
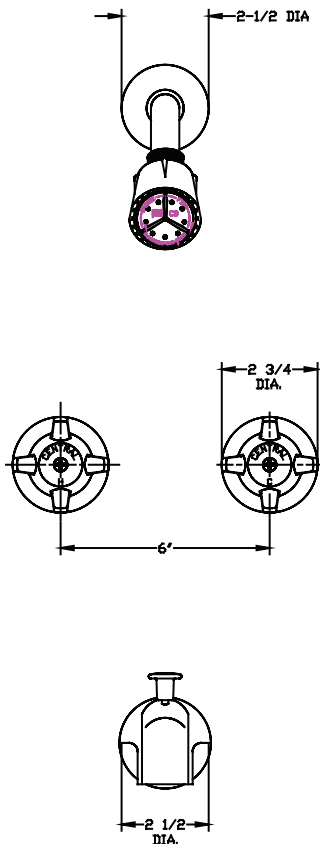

Central Brass

C O M P A N Y

Brecksville, Ohio 44141

Phone: (216) 883-0220 Fax: (440) 526-5745

www.CentralBrass.com

6056 6076
6086-Z 6266
TWO-VALVE
BATH/SHOWER FITTING

Spout variations available

Z - Suffix
Zamak Spout

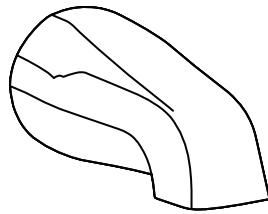

3154-Z

Accessories available

Brass
Stem Extension

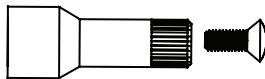

G-1548-ET
(Available Separately)
Used for thicker wall dimensions