

WALL CAPS

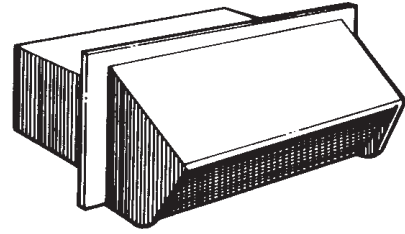

Model WC638

- For 3 1/4" x 14" duct
- Spring-loaded backdraft damper and bird screen
- 26 GA CRCQ Steel, black finish

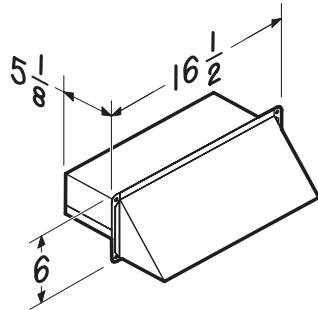

Model 639

- For 3 1/4" x 10" duct
- Spring-loaded backdraft damper and bird screen
- 24 GA CRCQ Steel, black electrically-bonded epoxy finish
- Do not use for dryer venting

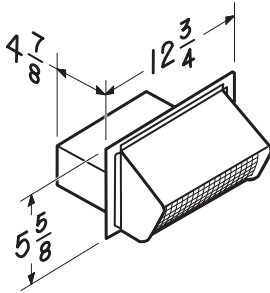

Model 649

- Same features as Model 639
- .025 Aluminum - natural finish

Model 647

- For 7" round duct
- Spring-loaded backdraft damper and bird screen
- .025 Aluminum - natural finish
- Do not use for dryer venting

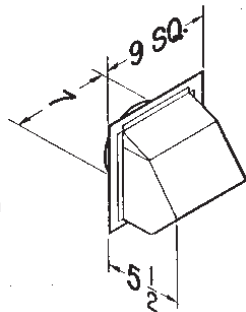

Model 843BL

- For 6" round duct
- Spring-loaded backdraft damper and bird screen
- 22 GA CRCQ Steel, black electrically-bonded epoxy finish
- Attachment collar 1 1/4" long
- Do not use for dryer venting

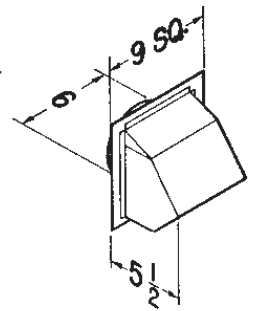

Model 641

- Same features as Model 843BL
- .025 Aluminum - natural finish

Model 641FA

- Same features as Model 641
- Without backdraft damper
- Includes mesh screen
- Intended for make-up air inlet applications

Model 885BL

- For 3" or 4" round duct (4" to 3" transition included)
- Spring-loaded backdraft damper and bird screen
- 24 GA CRCQ Steel, black electrically-bonded epoxy finish
- Do not use for dryer venting

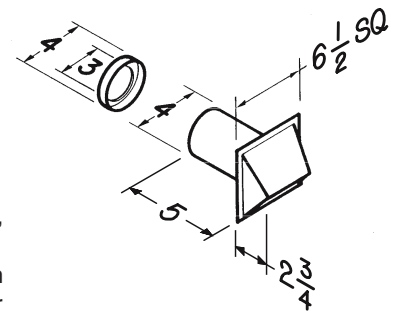

Broan-NuTone LLC Hartford, Wisconsin www.broan.com 800-558-1711

REFERENCE	QTY.	REMARKS	Project
			Location
			Architect
			Engineer
			Contractor
			Submitted by
			Date