

MODEL 433 AUTOMATIC SHUTTER

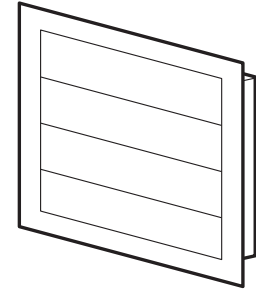

Combine this shutter with Model 353 or Model 35316 ventilators to get optimum efficiency and performance.

FEATURES

- Counter-balanced aluminum vanes - open and close as fan starts and stops
- Better air flow than stationary attic louvers
- Extruded aluminum construction - fits flush with outside wall
- The frame material is fabricated from .080 - 6063-T6 extruded aluminum
- The louvers are fabricated from .016 - 3105-H28 aluminum coil

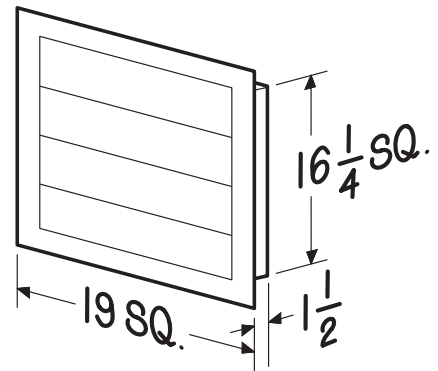

Broan-NuTone LLC Hartford, Wisconsin www.broan.com 800-558-1711

REFERENCE	QTY.	REMARKS	Project
			Location
			Architect
			Engineer
			Contractor
			Submitted by
			Date