

Light Duty Commercial Atmospheric Vent Energy Saver Gas Water Heater



Photo is of
65T-65FB-3N

FEATURING:



LLC - Low Lead Content

The Atmospheric Vent FVIR Defender Safety System[®] Models Feature:

- **Bradford White ICON System[™]**—Intelligent gas control with proven millivolt powered technology and built-in piezo igniter. A standard, off the shelf thermopile converts heat energy from the pilot flame into electrical energy to operate the gas valve and microprocessor. No need for external electricity.
 - **Enhanced Performance**—Proprietary algorithms provide enhanced First Hour Delivery ratings and tighter temperature differentials.
 - **Advanced Temperature Control System**—Microprocessor constantly monitors and controls burner operation to maintain consistent and accurate water temperature levels (up to 180°F).
 - **Intelligent Diagnostics**—An exclusive green LED light prompts the installer during start-up and provides ten different diagnostic codes to assist in troubleshooting.
 - **Pilot On Indication**—Flashing green LED provides positive indication that pilot is on.
 - **Separate Immersed Thermowell**—High strength advanced polymer composite thermowell provides isolation between electric temperature sensor and surrounding water. No need to drain the tank when removing gas valve.
- **Advanced ScreenLok[®] Technology Flame Arrestor Design**—Flame arrestor is designed to prevent ignition of flammable vapor outside of the water heater.
- **Resettable Thermal Switch**—Proven and reliable bimetallic switch prevents burner and pilot operation in case of ongoing flammable vapor burn inside of the combustion chamber or restricted air flow.
- **Maintenance Free**—No regular cleaning of air inlet openings or flame arrestor is required under normal conditions.
- **Sight Window**—Offers a view into the combustion chamber to observe the operation of the pilot and burner.
- **Factory Installed Hydrojet[®] Total Performance System**—Cold water inlet sediment reducing device helps prevent sediment build up in tank. Increases first hour delivery of hot water while minimizing temperature build up in tank.
- **Vitraglas[®] Lining**—Bradford White tanks are lined with a exclusively engineered enamel formula that provides superior protection from the highly corrosive effects of hot water. This formula (Vitraglas[®]) is fused to the steel surface by firing at a temperature of over 1600°F.
- **Side Connections**—3/4" NPT tapings allow easy connections for space heating applications (potable water only).
- **2" Non-CFC Foam Insulation**—Covers the sides and top of tank, reducing the amount of heat loss. This results in less energy consumption, improved operation efficiencies and jacket rigidity.
- **Pedestal Base.**
- **Water Connections**—3/4" NPT factory installed true dielectric fittings.
- **Factory Installed Heat Traps.**
- **Protective Magnesium Anode Rod.**
- **4" "Snap Lock" Draft Diverter.**
- **T&P Relief Valve**—Installed.
- **Low Restriction Brass Drain Valve**—Durable tamper proof design.

3 or 5-Year Limited Tank Warranties / 1-Year Limited Warranty on Component Parts.

For more information on warranty, please visit www.bradfordwhite.com

For products installed in USA, Canada and Puerto Rico. Some states do not allow limitations on warranties. See complete copy of the warranty included with the heater.

Commercial Atmospheric Vent Gas Water Heater

Light Duty Energy Saver Models

NATURAL GAS AND LIQUID PROPANE GAS

Meet or exceed ASHRAE 90.1b (current standard) C.E.C. Listed
79% Recovery Efficiency

| Model Number | Capacity | | Nat. BTU/Hr. Input | | First Hour Rating** Gal. | Recovery at 100°F Rise* | | | | A Floor to Flue Conn. in. | B Jacket Dia. in. | C Vent Size in. | D Floor to T&P Conn. in. | E Floor to Gas Conn. in. | F Floor to Space Htg. Return in. | G Floor to Space Htg. Outlet in. | H Floor to Water Conn. in. | K Depth in. | Approx. Shipping Weight lbs. |
|--------------|-----------|-----------|--------------------|------------------|--------------------------|-------------------------|---------------|----------|-------------|--------------------------------|-------------------|-----------------|--------------------------------|---------------------------------|----------------------------------|----------------------------------|--------------------------------|-------------|------------------------------|
| | U.S. Gal. | Imp. Gal. | BTU/Hr. Input | LP BTU/Hr. Input | | Nat. U.S. GPH | Nat. Imp. GPH | U.S. GPH | LP Imp. GPH | | | | | | | | | | |
| 50T-65FB-3N | 48 | 40 | 65,000 | 61,000 | 103 | 63 | 53 | 59 | 49 | 59 ¹ / ₄ | 22 | 4 | 50 | 13 | 13 ¹ / ₂ | 50 | 57 | 26 | 164 |
| 65T-65FB-3N | 65 | 54 | 65,000 | 63,000 | 127 | 63 | 53 | 61 | 51 | 63 | 24 | 4 | 53 ¹ / ₂ | 12 ² / ₁₆ | 13 ¹ / ₂ | 53 ¹ / ₂ | 60 ³ / ₄ | 28 | 205 |

| Model Number | Capacity | | Nat. kW Input | | First Hour Rating** Liters | Recovery at 56°C Rise* | | A Floor to Flue Conn. mm. | B Jacket Dia. mm. | C Vent Size mm. | D Floor to T&P Conn. mm. | E Floor to Gas Conn. mm. | F Floor to Space Htg. Return mm. | G Floor to Space Htg. Outlet mm. | H Floor to Water Conn. mm. | K Depth mm. | Approx. Shipping Weight kg. |
|--------------|----------|--|---------------|-------------|----------------------------|------------------------|----------------|---------------------------|-------------------|-----------------|--------------------------|--------------------------|----------------------------------|----------------------------------|----------------------------|-------------|-----------------------------|
| | Liters | | Nat. kW Input | LP kW Input | | Nat. Liters/Hour | LP Liters/Hour | | | | | | | | | | |
| 50T-65FB-3N | 182 | | 19.1 | 17.9 | 390 | 238 | 223 | 1550 | 559 | 102 | 1270 | 330 | 343 | 1270 | 1448 | 660 | 74 |
| 65T-65FB-3N | 246 | | 19.1 | 18.4 | 481 | 238 | 231 | 1600 | 609 | 102 | 1359 | 309 | 342 | 1359 | 1543 | 711 | 93 |

Propane models feature a Titanium Stainless Steel propane burner. For Propane (LP) models change suffix "B" to "S" and "N" to "X".

For 5 year models, change suffix "3" to "5".

*Based on manufacturers rated recovery efficiency.

**First Hour Rating is based on the latest AHRI Directory listings.

NSF kits available.

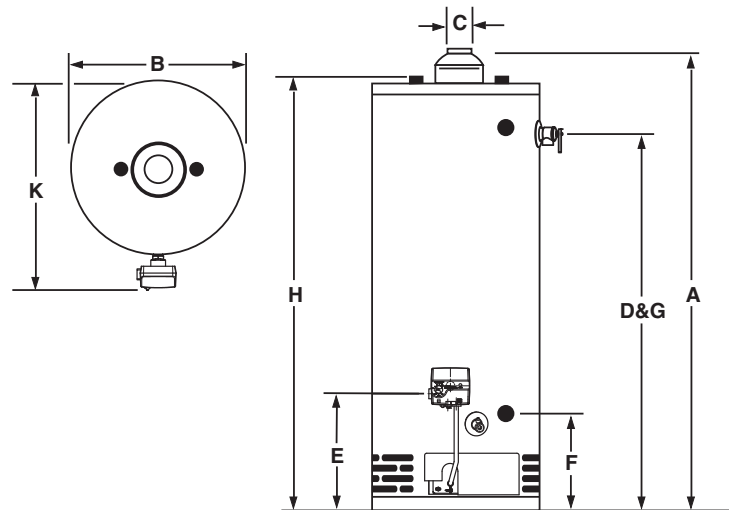

Meets NAECA Requirements

General

All gas water heaters are certified at 300 PSI test pressure (2068 kPa) and 150 PSI working pressure (1034 kPa). All potable water connections are 3/4" NPT (19mm) on 8" (203mm) centers. All gas connections 1/2" (13mm).

All models design certified by CSA International (formerly AGA/CGA), ANSI standard Z-21.10.1 and peak performance rated.

Dimensions and specifications subject to change without notice in accordance with our policy of continuous product improvement.

Suitable for Water (Potable) Heating and Space Heating.

Toxic chemicals, such as those used for boiler treatment, shall NEVER be introduced into this system. This unit may NEVER be connected to any existing heating system or component(s) previously used with a non-potable water heating appliance.



For U.S. and Canada field service, contact your professional installer or local Bradford White sales representative.

Sales 800-523-2931 • Fax 215-641-1670 / Technical Support 800-334-3393 • Fax 269-795-1089 • Warranty 800-531-2111 • Fax 269-795-1089

International: Telephone 215-641-9400 • Telefax 215-641-9750 / www.bradfordwhite.com

BRADFORD WHITE-CANADA INC. Sales / Technical Support 866-690-0961 / 905-238-0100 • Fax 905-238-0105 / www.bradfordwhite.com

Built to be the Best™

©2013, Bradford White Corporation. All rights reserved.