

Class 150 (Standard)

FIG. 3105R

Reducing Tee

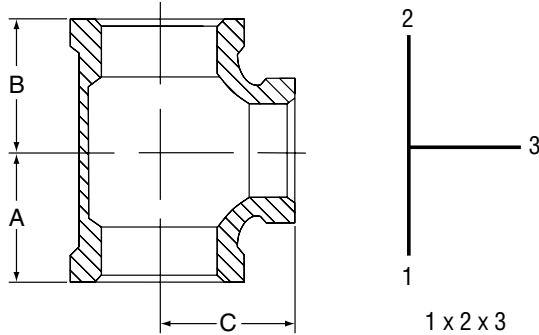

For Listings/Approval Details and Limitations, visit our website at www.anvilintl.com or contact an Anvil® Sales Representative.

FIGURE 3105R - REDUCING TEE							
Nominal Size			Dimensions			Approx. Wt. Each	
1	2	3	A	B	C		
In. (mm)			In. (mm)	In. (mm)	In. (mm)	Lbs. (kg)	
1/2 15	1/2 15	1/4	0.97	0.97	0.98	0.24	
		8	24.64	24.64	24.89	0.11	
		3/8	1.04	1.04	1.03	0.27	
		10	26.42	26.42	26.16	0.12	
		3/4	1.22	1.22	1.20	0.37	
		20	30.99	30.99	30.48	0.17	
		1	1.36	1.36	1.26	0.49	
		25	34.54	34.54	32.00	0.22	
3/4 20	1/2 15	1/2	1.20	1.12	1.22	0.38	
		15	30.48	26.16	28.45	0.17	
		3/4	1.31	1.22	1.31	0.45	
			20	33.27	28.45	33.27	0.20
	3/4 20	3/4 20	1/4	1.05	1.05	1.08	0.36
			8	26.67	26.67	27.43	0.16
			3/8	1.12	1.12	1.13	0.39
			10	28.45	28.45	28.70	0.18
			1/2	1.20	1.20	1.22	0.43
			15	30.48	30.48	30.99	0.20
		1	1.45	1.45	1.37	0.62	
		25	36.83	36.83	28.45	0.28	
1 25	1/4 8	1	1.50	1.18	1.50	0.63	
		25	38.10	29.97	38.10	0.29	
	1/2 15	1/2	1.26	1.12	1.36	0.48	
		15	32.00	28.45	34.54	0.22	
		3/4	1.37	1.22	1.45	0.56	
		20	34.80	28.45	34.54	0.25	
		1	1.50	1.36	1.50	0.67	
		25	38.10	34.54	38.10	0.30	

MATERIAL SPECIFICATIONS

Dimensions: Fittings: ASME B16.3
 Unions: ASME B16.39
 Bushings/Plugs: ASME B16.14
 Material: ASTM A-197
 Finish: Black or Hot Dip Galvanized per ASTM A153 Class A
 Threads*: NPT per ASME B1.20.1
 Pressure Ratings: Fittings: ASME B16.3
 Unions: ASME B16.39
 Bushings/Plugs: ASME B16.14
 Pressure Testing: All malleable iron fittings are tested for through wall porosity using an air under water process.
 Agency Approvals: All malleable iron fittings and unions are UL/ULC Listed and FM Approved.

* British Standard threading per BS 21 available upon request.

PROJECT INFORMATION		APPROVAL STAMP
Project:		<input type="checkbox"/> Approved
Address:		<input type="checkbox"/> Approved as noted
Contractor:		<input type="checkbox"/> Not approved
Engineer:		Remarks:
Submittal Date:		
Notes 1:		
Notes 2:		

Class 150 (Standard)

FIG. 3105R

Reducing Tee

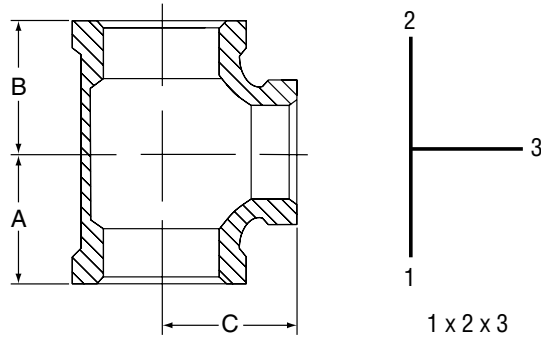

FIGURE 3105R - REDUCING TEE							
Nominal Size			Dimensions			Approx. Wt. Each	
1	2	3	A	B	C		
In. (mm)			In. (mm)	In. (mm)	In. (mm)	Lbs. (kg)	
1 25	3/4 20	1/2	1.26 32.00	1.20 30.48	1.36 34.54	0.53 0.24	
		3/4	1.37 34.80	1.31 33.27	1.45 36.83	0.61 0.28	
		1	1.50 38.10	1.45 36.83	1.50 38.10	0.71 0.32	
	1 25	3/8 10	3/8	1.18 29.97	1.18 29.97	1.27 32.26	0.57 0.26
			1/2	1.26 32.00	1.26 32.00	1.36 34.54	0.62 0.28
			3/4	1.37 28.45	1.37 28.45	1.45 36.83	0.69 0.31
		1 25	1 1/4	1.67 42.42	1.67 42.42	1.58 40.13	0.94 0.43
			1 1/2	1.80 45.72	1.80 45.72	1.65 41.91	1.07 0.49
			2	2.02 51.31	2.02 51.31	1.73 43.94	1.45 0.66
	1 1/4 32	1/2 15	1	1.58 40.13	1.36 34.54	1.67 42.42	0.82 0.37
			1 1/4	1.75 44.45	1.53 38.86	1.75 44.45	0.95 0.43
		3/4 20	3/4	1.45 36.83	1.31 33.27	1.62 41.15	0.75 0.34
1			1.58 40.13	1.45 36.83	1.67 42.42	0.87 0.39	
1 1/4			1.75 44.45	1.62 41.15	1.75 44.45	1.00 0.45	
1 25		1/2 15	1/2	1.34 34.04	1.26 32.00	1.53 38.86	0.74 0.34
			3/4	1.45 36.83	1.37 28.45	1.62 41.15	0.82 0.37
		1	1.58 40.13	1.50 38.10	1.67 42.42	0.94 0.43	
		1 1/4	1.75 44.45	1.67 42.42	1.75 44.45	1.08 0.49	
		3/2	1.88 47.75	1.88 47.75	1.82 46.23	1.34 0.61	

FIGURE 3105R - REDUCING TEE							
Nominal Size			Dimensions			Approx. Wt. Each	
1	2	3	A	B	C		
In. (mm)			In. (mm)	In. (mm)	In. (mm)	Lbs. (kg)	
1 1/4 32	1 1/4 32	3/8	1.26 32.00	1.26 32.00	1.44 36.58	0.78 0.35	
		1/2	1.34 34.04	1.34 34.04	1.53 38.86	0.84 0.38	
		3/4	1.45 36.83	1.45 36.83	1.62 41.15	0.92 0.42	
		1	1.58 40.13	1.58 40.13	1.67 42.42	1.04 0.47	
		1 1/2	1.88 47.75	1.88 47.75	1.82 46.23	1.34 0.61	
		2	2.10 53.34	2.10 53.34	1.90 48.26	1.65 0.75	
	1 1/2 40	1/2 15	1 1/2	1.94 49.28	1.66 42.16	1.94 49.28	1.24 0.56
			3/4	1.50 38.10	1.26 32.00	1.69 42.93	0.86 0.39
		3/4 20	1 1/2	1.94 49.28	1.75 44.45	1.94 49.28	1.29 0.59
			1	1.65 41.91	1.50 38.10	1.80 45.72	1.08 0.49
			1 1/4	1.82 46.23	1.67 42.42	1.88 47.75	1.23 0.56
		1 25	1 1/2	1.94 49.28	1.80 45.72	1.94 49.28	1.35 0.61
3/4			1.52 38.61	1.45 36.83	1.75 44.45	1.04 0.47	
1			1.65 41.91	1.58 40.13	1.80 45.72	1.17 0.53	
1 1/2 40		1 1/4 32	1 1/4	1.82 46.23	1.75 44.45	1.88 47.75	1.32 0.60
			1 1/2	1.94 49.28	1.88 47.75	1.94 49.28	1.45 0.66
			2	2.10 53.34	2.10 53.34	1.90 48.26	1.82 0.83
		1 1/2 40	1/2 15	1/2	1.41 35.81	1.41 35.81	1.66 42.16
	3/4			1.52 38.61	1.52 38.61	1.75 44.45	1.14 0.52
	1			1.65 41.91	1.65 41.91	1.80 45.72	1.27 0.58
	1 25		1 1/4	1.82 46.23	1.82 46.23	1.88 47.75	1.43 0.65
			2	2.16 54.86	2.16 54.86	2.02 51.31	1.89 0.86

Class 150 (Standard)

FIG. 3105R

Reducing Tee

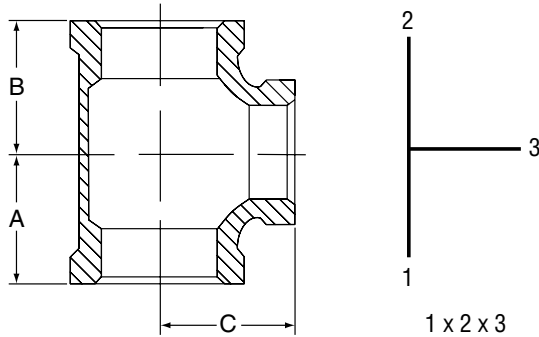

FIGURE 3105R - REDUCING TEE							
Nominal Size			Dimensions			Approx. Wt. Each	
1	2	3	A	B	C		
In. (mm)			In. (mm)	In. (mm)	In. (mm)	Lbs. (kg)	
2 50	1/2 15	2	2.25 57.15	1.88 47.75	2.25 57.15	1.89 0.86	
		3/4	2.25 57.15	1.97 50.04	2.25 57.15	1.93 0.88	
	1 25	1	1.81 45.97	1.75 44.45	1.87 47.50	1.39 0.63	
		2	2.25 57.15	2.02 51.31	2.25 57.15	2.00 0.91	
	1 1/4 32	1 1/4	1.90 48.26	1.75 44.45	2.10 53.34	1.64 0.74	
		1 1/2	2.02 51.31	1.88 47.75	2.16 54.86	1.80 0.82	
		2	2.25 57.15	2.10 53.34	2.25 57.15	2.09 0.95	
	1 1/2 40	1	1.73 43.94	1.65 41.91	2.02 51.31	1.57 0.71	
		1 1/4	1.90 48.26	1.82 46.23	2.10 53.34	1.71 0.78	
		1 1/2	2.02 51.31	1.94 49.28	2.16 54.86	1.88 0.85	
		2	2.25 57.15	2.16 54.86	2.25 57.15	2.21 1.00	
		2 1/2	2.60 66.04	2.16 54.86	2.39 60.71	3.15 1.43	
	2 50	1/2 15	1/2	1.49 37.85	1.49 37.85	1.88 47.75	1.53 0.69
			3/4	1.60 40.64	1.60 40.64	1.97 50.04	1.63 0.74
		1 25	1	1.73 43.94	1.73 43.94	2.02 51.31	1.78 0.81
			1 1/4	1.90 48.26	1.90 48.26	2.10 53.34	1.97 0.89
		1 1/2 40	1 1/2	2.02 51.31	2.02 51.31	2.16 54.86	2.12 0.96
			2 1/2	2.60 66.04	2.60 66.04	2.39 60.71	3.15 1.43

FIGURE 3105R - REDUCING TEE						
Nominal Size			Dimensions			Approx. Wt. Each
1	2	3	A	B	C	
In. (mm)			In. (mm)	In. (mm)	In. (mm)	Lbs. (kg)
2 1/2 65	2 1/2 65	3/4	1.74 44.20	1.74 44.20	2.32 58.93	2.67 1.21
		1	1.87 47.50	1.87 47.50	2.37 60.20	2.84 1.29
		1 1/4	2.04 51.82	2.04 51.82	2.45 62.23	3.09 1.40
		1 1/2	2.16 54.86	2.16 54.86	2.51 63.75	3.29 1.49
		2	2.39 60.71	2.39 60.71	2.60 66.04	3.65 1.66
		2	2.52 64.01	2.25 57.15	2.89 73.41	3.88 1.76
3 80	3 80	3/4	1.87 47.50	1.87 47.50	2.61 66.29	3.72 1.69
		1	2.00 50.80	2.00 50.80	2.66 67.56	3.96 1.80
		1 1/4	2.17 55.12	2.17 55.12	2.74 69.60	4.23 1.92
		1 1/2	2.29 58.17	2.29 58.17	2.80 71.12	4.45 2.02
		2	2.52 64.01	2.52 64.01	2.89 73.41	4.90 2.22
		2 1/2	2.83 71.88	2.83 71.88	2.99 75.95	5.69 2.58
		2	2.74 69.60	2.74 69.60	3.41 86.61	7.52 3.41
4 100	4 100	2 1/2	3.05 77.47	3.05 77.47	3.51 89.15	8.51 3.86
		3	3.30 83.82	3.30 83.82	3.60 91.44	9.25 4.20