

EPOXY RETENTION TANKS



FEATURES:

- Heavy gauge steel construction
- Baked epoxy coating on both interior and exterior
- Epoxy coating complies with F.D.A.
- Tested to 100 psig (air)
- Maximum working pressure - 75 psig
- 3 Year limited warranty

Epoxy Retention Tanks

Model No.	Volume (Gallons)	Tank Dimensions (in inches)							Maximum Acceptance	System Drawdown Volume (Gallons)			
		A	B	C	D	E	F	G		20/40	30/50	40/60	50/70
ERT42T	42	16	53	14	9	29	46		100%	6.5	4.2	3.0	2.2
ERT42S	42	20	36	17.8	8.5	20	28		100%	6.5	4.2	3.0	2.2
ERT80	80	20	64	17.8	8.5	34	51.5		100%	12.4	8.1	5.8	4.2
ERT120	120	24	66	22.1	6.5	32	56		100%	18.6	12.1	8.6	6.3
ERT220	220	30	77		6.5	36.5	14	7	100%	34.1	22.2	15.8	11.7
ERT315	315	36	78		6.5	36.5	14	7	100%	48.8	32.0	22.7	16.7

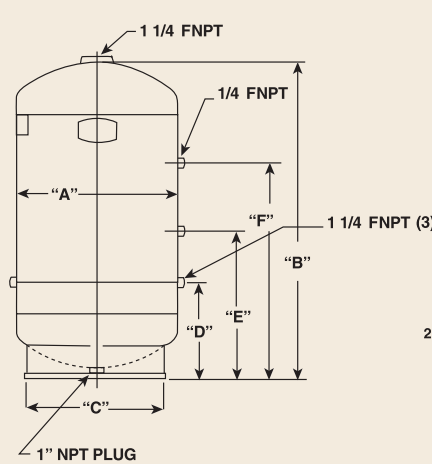

ERT42T, 42S, 80 & 120

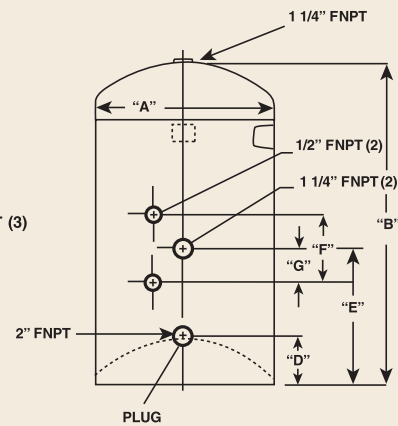

ERT220 & 315

Ask for Quality. Ask for AMTROL.™

 www.amtrol.com	Corporate Headquarters 1400 Division Road West Warwick, RI 02893 Telephone: 401-884-6300 Fax: 401-884-4773	AMTROL Canada, Ltd. 275 Shoemaker Street Kitchener, Ontario N2E 3B3 Telephone: 800-256-3188 Fax: 519-748-4231
---	--	---